



WENCON USER MANUAL

About Wencon

Wencon is a worldwide operating company specialised in solutions for rebuilding, protection and life extension of metal exposed to corrosion, galvanic corrosion, cavitation, wear or breakage. The Wencon repair concept is widely used in the marine and the offshore industry.

Our goal is to help you to perform your repair tasks quickly and effectively and thereby reduce downtime. With our global network of Partners, we are dedicated to support you and ready to deliver to you within very short notice.

Thousands of ships around the world carry Wencon products and manuals on board, ready for immediate use in case of leaks and malfunctions caused by corrosion or abrasion in vital machine parts on ships and off-shore installations.

To find a workshop or service partner near you, we invite you to visit us on www.wencon.com



On board and temporary Repairs



On-site repairs and maintenance



Solutions done by workshop or shipyard

1. PRODUCT INFORMATION

2. INSTRUCTION FOR USE

3. TECHNICAL INFORMATION

4. SURFACE PREPARATION

5. APPLICATION DATA SHEET

6. TYPE APPROVAL CERTIFICATES

Index - Chapter 1

Wencon Cream	1
Wencon Rapid	3
Wencon Coating	5
Wencon Hi-Temp	7
Wencon Putty	9
Wencon Pipe Tape	11
Wencon Exhaust Repair kit	13
Wencon UW Putty for wet surfaces or under water	15
Wencon UW Cream for wet surfaces or under water	17
Wencon UW Coating for wet surfaces or under water	19
Wencon UW Coating (Low Viscosity)	21
Wencon Ceramic Cream	23
Wencon Ceramic Coating	25
Wencon Accessories	27
Wencon Cleaner	27
Wencon Bio Cleaner	27
Wencon Release Agent	27
Wencon Reinforcement Tape	27
Wencon Application Tools	27
Rotating Blaster	29
Wencon Repair Kits	31

Wencon Cream

The basic multi purpose epoxy compound for repair and rebuilding of deteriorated metal parts.

- Wide range of applications
- Strong adhesion to all metal surfaces
- Low curing temperature
- Simple mixing and application
- Fully machinable

General information

Wencon Cream is a basic two-component epoxy compound suitable for a wide range of applications. The compound is for repair and rebuilding of worn, damaged, cracked and corroded metal parts. Wencon Cream is also excellent as a filling compound.

Wencon Cream shows many of the characteristics of metals, which together with outstanding adhesion to all metallic surfaces makes the repair compound highly suitable for repair of corroded and worn metals.

Wencon Cream is non conducting and will therefore not cause bi-metallic corrosion. After curing the compound is resistant to oil, water, salt water and most diluted acids and a range of solvents. Heat resistance ranges from 60° C (140° F) in corrosive and heavy load environments and up to 250° C (482°F) when applied as a filling compound.

Application areas

Typical applications are corroded tanks, pump housings, impellers, valves, pipes, flange faces, roller bearing seats, worn shafts, hydraulic rams and heat exchangers. Wencon Cream is also excellent as a filling compound.

Mixing

Wencon products are designed to be simple to use and cost effective. Easy mixing ratios (1:1 by volume) reduce waste to a minimum and high specific volume gives high coverage rates.



Product numbers:

No. 1010 Wencon Cream, 1 kg (2,2 lb) unit

IMPA no.

812335

ISSA no.

75.553.20

GENERAL DESCRIPTION

Two-component solvent free paste consistency epoxy repair compound.

SURFACE PREPARATION

The surface must always be dry, clean and degreased

Applying to new steel surface:

- Grit blasting to SA 2,5
- if Grit blasting is not possible use grinding
- after grinding the surface must be degreased with Wencon Bio Cleaner

Repairing old steel surface:

- Grit blasting to SA 2,5
- Sweat out water and salts
- Grit blasting to SA 2,5 again
- Profile Rz 75-110 microns

MIXING RATIO

Mix by volume 1:1. Mix until an even colour is obtained.

POT LIFE

Depending on amount mixed and temperature. Mixed in small amounts, the pot life is approximately 30-60 minutes at 20°C (68°F)

APPLYING

Wencon Cream has a paste consistency and is applied by spatula, also on vertical surfaces.

CURING TIME

Curing will take place in 10-15 hours at 20°C (68°F)

REDUCED CURING TIME WITH INFRARED

This product is tested with and suitable for infrared curing. Curing with infrared radiation can reduce curing time significantly. Result can vary, depending on circumstances and equipment used.

MACHINABLE

After curing, the product can be machined, drilled and worked like metal.

TECHNICAL DATA

Hardness Shore D: 75 (**DIN 53505**)

Tensile strength: 14,3 N/mm² - 2035 p.s.i. (**DIN 53454**)

Compressive strength:

Modulus of elasticity: 1689 N/mm² - 240,000 p.s.i. (**DIN 53454**)

Rcrack: 58 N/mm² - 8,500 p.s.i. (**DIN 53454**)

Shear adhesion: 14,40 N/mm² - (**ASTM D1002**)

Adhesion to steel: 3,0 N/mm²- (**ISO 4624**)

SPECIFIC VOLUME

775 cm³ per kilogramme (47,3 cu inch/kg)

TEMPERATURE RESISTANCE

Corrosion: 60°C (140° F)

Light load: 120°C (248°F)

As filler: 250°C (482°F)

CHEMICAL RESISTANCE

The compound is resistant to oil, water, salt water and most diluted acids and alkalis as well as a range of solvents.

SHELF LIFE

At 20°C (68°F) : 3 years

HANDLING PRECAUTIONS

Read the Wencon Instruction for Use and the Safety Data Sheet.

Wencon Rapid

The fast curing multi purpose epoxy compound for repair and rebuilding of deteriorated metal parts.

- Wide range of applications
- Fast curing – reduced down time
- Strong adhesion to all metal surfaces
- Simple mixing and application
- Convenient unit sizes

General information

Wencon Rapid is a fast curing, two-component epoxy compound suitable for a wide range of applications within emergency repairs and maintenance.

Wencon Rapid shows many of the characteristics of metals, which together with outstanding adhesion to all metallic surfaces makes the repair compound highly suitable for repair of corroded and worn metals.

Wencon Rapid is non conducting and will therefore not cause bi-metallic corrosion. After curing the compound is resistant to oil, water, salt water and most diluted acids and a range of solvents. Heat resistance ranges from 60° C (140°F) in corrosive and heavy load environments and up to 250° C (482°F) when applied as a filling compound.

Application areas

Wencon Rapid is very suitable for applications where thicker layers of material are required, as the compound quickly sets and becomes solid. Typical applications are corroded tanks, pump housings and impellers, valves, tubes, pipes, heat exchangers, flange faces, seats, worn shafts, hydraulic rams and all emergency repairs, where a short curing time is required. The compound can also be used as a filling compound.

Mixing

Wencon products are designed to be simple to use and cost effective. Easy mixing ratio (1:1 by volume) reduces waste to a minimum and high specific volume gives high coverage rates.



Product numbers:

No. 1000	Wencon Rapid, 1 kg (2,2 lb) unit
No. 1005	Wencon Rapid 8, 8x125g (8x0,28 lb) unit

IMPA no.

812347
812343

ISSA no.

75.553.21
75.553.22

GENERAL DESCRIPTION

Fast curing two-component solvent free paste consistency epoxy repair compound.

SURFACE PREPARATION

The surface must always be dry, clean and degreased

Applying to new steel surface:

- Grit blasting to SA 2,5
- if Grit blasting is not possible use grinding
- after grinding the surface must be degreased with Wencon Bio Cleaner

Repairing old steel surface:

- Grit blasting to SA 2,5
- Sweat out water and salts
- Grit blasting to SA 2,5 again
- Profile Rz 75-110 microns

MIXING RATIO

Mix by volume 1:1. Mix until an even colour is obtained.

POT LIFE

Depending on amount mixed and temperature. Mixed in small amounts, the pot life is approximately 10-20 minutes at 20°C (68°F)

APPLYING

Wencon Rapid has a paste consistency and is applied by spatula, also on vertical surfaces.

CURING TIME

Curing will take place in 40-90 minutes at 20°C (68°F)

REDUCED CURING TIME WITH INFRARED

This product is tested with and suitable for infrared curing. Curing with infrared radiation can reduce curing time significantly. Result can vary, depending on circumstances and equipment used.

MACHINABLE

After curing, the product can be machined, drilled and worked like metal.

TECHNICAL DATA

Hardness Shore D: 81 (**DIN 53505**)

Tensile strength: 9,2 N/mm² - 1310 p.s.i. (**DIN 53454**)

Compressive strength:

Modulus of elasticity: 2891 N/mm² - 411,000 p.s.i. (**DIN 53454**)

Rcrack: 112 N/mm² - 16,000 p.s.i. (**DIN 53454**)

Shear adhesion: 20 N/mm² - (**ASTM D1002**)

Adhesion to steel: 2,0 N/mm²- (**ISO 4624**)

SPECIFIC VOLUME

709 cm³ per kilogramme (43,3 cu inch/kg)

TEMPERATURE RESISTANCE

Corrosion: 60°C (140° F)

Light load: 120°C (248°F)

As filler: 250°C (482°F)

CHEMICAL RESISTANCE

The compound is resistant to oil, water, salt water and most diluted acids and alkalis as well as a range of solvents.

SHELF LIFE

At 20°C (68°F) : 3 years

HANDLING PRECAUTIONS

Read the Wencon Instruction for Use and the Safety Data Sheet.

Wencon Coating

The versatile and cost effective coating product for general repair, maintenance and protection jobs.

- Strong adhesion to all metal surfaces
- Efficient double coat system
- Easy mixing and application
- High coverage rate
- Fully machinable

General information

Wencon Coating is a two-component, liquid epoxy coating suitable for a wide range of applications. It provides a smooth non porous surface, which is resistant to bi-metallic corrosion, light chemical aggression, corrosion and erosion as well as impingement.

Wencon Coating offers resistance to oil, water, salt water and most diluted acids and alkalis as well as a range of solvents. Heat resistance ranges from 60° C (140°F) in corrosive and heavy load environments and up to 250° C (482°F) when applied as a filling compound.

Wencon Coating is a double coat system and is consequently supplied in two different colours, white and blue.

Application areas

Wencon Coating is used for a variety of small and large repair and maintenance jobs. Typical applications are coating of surfaces rebuild after deterioration. Wencon Coating is used for coating of new parts, or protection of pumps, valves, wet liners, cooler end covers or other surfaces, against corrosion and bi-metallic corrosion.

Mixing

The Wencon products are designed to be simple to use and cost effective. Easy mixing ratio (1:2 by volume) reduce waste to a minimum and high specific volume gives high coverage rates.



Product numbers:

No. 1020	Wencon Coating, white 0,5 kg (1,1 lb) unit
No. 1030	Wencon Coating, blue 0,5 kg (1,1 lb) unit

IMPA no.

812337
812338

ISSA no.

75.553.10
75.553.11

GENERAL DESCRIPTION

Two-component solvent free liquid epoxy coating for protection against bi-metallic corrosion, galvanic corrosion and erosion.

SURFACE PREPARATION

The surface must always be dry, clean and degreased

Applying to new steel surface:

- Grit blasting to SA 2,5
- Profile 75 microns

Repairing old steel surface:

- Grit blasting to SA 2,5
- Sweat out water and salts
- Profile Rz 75-110 microns

MIXING RATIO

Mix by volume 1:2. Mix until an even colour is obtained.

POT LIFE

Depending on amount mixed and temperature. Mixed in small amounts, the pot life is approximately 20-30 minutes at 20°C (68°F)

APPLYING

Wencon Coating is liquid and is applied by brush, roller or spatula.

OVER COATING

Wencon Coating is a double coat system. The over coating time can vary from one to three hours depending on temperature. The second coat must be applied whilst the first coat is still tacky. If full curing has occurred a light sandblasting or grinding is necessary prior to the second coat

CURING TIME

Curing will take place in 10-15 hours at 20°C (68°F)

MACHINABLE

After curing, the product can be machined, drilled and worked like metal.

REDUCED CURING TIME WITH INFRARED

This product is tested with and suitable for infrared curing. Curing with infrared radiation can reduce curing time significantly. Result can vary, depending on circumstances and equipment used.

COVERAGE RATE

Theoretical: 0,80 kg per m² (0,16 lb/sq. ft.) at 600 microns

Practical: 1,0 kg per m² (0,20 lb/sq. ft.)

TECHNICAL DATA

Hardness Shore D: 80 (DIN 53505)

Tensile strength: 12,9 N/mm² - 1835 p.s.i. (DIN 53454)

Compressive strength:

Modulus of elasticity: 2199 N/mm² - 314,000 p.s.i. (DIN 53454)

Rcrack: 95 N/mm² - 13,500 p.s.i. (DIN 53454)

Shear adhesion: 16,20 N/mm² - (ASTM D1002)

Adhesion to steel: 6,0 N/mm² - (ISO 4624)

SPECIFIC VOLUME

730 cm³ per kilogramme (44,6 cu inch/kg)

TEMPERATURE RESISTANCE

Corrosion: 60°C (140° F)

Light load: 120°C (248°F)

As filler: 250°C (482°F)

CHEMICAL RESISTANCE

The compound is resistant to oil, water, salt water and most diluted acids and alkalis as well as a range of solvents.

SHELF LIFE

At 20°C (68°F) : 3 years

HANDLING PRECAUTIONS

Read the Wencon Instruction for Use and the Safety Data Sheet.

QUALITY TEST

Poretest and test of layer thickness can be tested with normal electronic instrument like high voltage and high frequency.

Wencon Hi-Temp

The high performance coating product for repair and protection in high temperature and aggressive environments.

- High temperature resistance
- Light chemical resistance
- Excellent mechanical wear properties
- Strong adhesion to all metal surfaces
- Fully machinable

General information

Wencon Hi-Temp is a high performance two-component liquid epoxy coating developed for applications in high load areas. It provides a smooth non porous surface, which is resistant to high temperatures, light chemical aggression and wear as well as bimetallic corrosion.

Wencon Hi-Temp offers resistance to oil, water, salt water and wide range of acids and alkalis as well as a range of solvents. Heat resistance ranges from 160° C (320°F) in corrosive and heavy load environments and up to 300° C (570°F) when applied as a filling compound.

Wencon Hi-Temp is a double coat system and is consequently supplied in two different colours, yellow and green.

Application areas

Wencon Hi-Temp is ideal for protection of tanks, pumps and valves against chemical and mechanical aggression, corrosion and bi-metallic corrosion. Typical applications are coating of surfaces rebuild with Wencon Cream, including repair of lining on inert gas systems, scrubber overboard pipes, fresh water generators, hot pipes and heating coils.

Mixing

The Wencon products are designed to be simple to use and cost effective. Easy mixing ratio (1:2 by volume) reduce waste to a minimum and high specific volume gives high coverage rates.

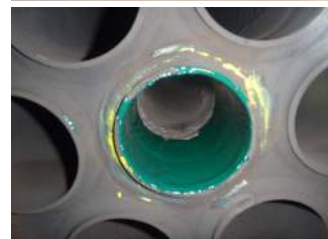

Product numbers:

No. 1050	Wencon Hi-Temp, yellow, 0,5 kg (1,1 lb) unit
No. 1060	Wencon Hi-Temp, green, 0,5 kg unit (1,1 lb)

IMPA no.

812345
812346

ISSA no.

75.553.12
75.553.13

GENERAL DESCRIPTION

Two-component solvent free liquid epoxy coating for protection against wear, bi-metallic corrosion and chemical aggression at high load areas and temperatures.

SURFACE PREPARATION

The surface must always be dry, clean and degreased

Applying to new steel surface:

- Grit blasting to SA 2,5
- Profile 75 microns

Repairing old steel surface:

- Grit blasting to SA 2,5
- Sweat out water and salts
- Profile Rz 75-110 microns

MIXING RATIO

Mix by volume 1:2. Mix until an even colour is obtained.

POT LIFE

Depending on amount mixed and temperature. Mixed in small amounts, the pot life is approximately 20-40 minutes at 20°C (68°F)

APPLYING

Wencon Hi-Temp is liquid and is applied by brush, roller or spatula.

OVER COATING

Wencon Hi-Temp is a double coat system. The over coating time can vary from one to three hours depending on temperature. The second coat must be applied whilst the first coat is still tacky. If full curing has occurred a light sandblasting or grinding is necessary prior to the second coat

CURING TIME

Curing will take place in 10-24 hours at 20°C (68°F)

MACHINABLE

After curing, the product can be machined, drilled and worked like metal.

REDUCED CURING TIME WITH INFRARED

This product is tested with and suitable for infrared curing. Curing with infrared radiation can reduce curing time significantly. Result can vary, depending on circumstances and equipment used.

COVERAGE RATE

Theoretical: 0,86 kg per m² (0,17 lb/sq. ft.) at 600 microns

Practical: 1,0 kg per m² (0,20 lb/sq. ft.)

TECHNICAL DATA

Hardness Shore D: 82 (DIN 53505)

Tensile strength: 13,8 N/mm² - 1960 p.s.i. (DIN 53454)

Compressive strength:

Modulus of elasticity: 4284 N/mm² - 610,000 p.s.i. (DIN 53454)

Rcrack: 96 N/mm² - 14,000 p.s.i. (DIN 53454)

Shear adhesion: 22,40 N/mm² - (ASTM D1002)

Adhesion to steel: 3,4 N/mm² - (ISO 4624)

SPECIFIC VOLUME

680 cm³ per kilogramme (41,5 cu inch/kg)

TEMPERATURE RESISTANCE

Corrosion: 160°C (320°F)

Light load: 220°C (428°F)

As filler: 300°C (572°F)

CHEMICAL RESISTANCE

The compound is resistant to oil, water, salt water and most diluted acids and alkalis as well as a range of solvents.

SHELF LIFE

At 20°C (68°F) : 3 years

HANDLING PRECAUTIONS

Read the Wencon Instruction for Use and the Safety Data Sheet.

QUALITY TEST

Poretest and test of layer thickness can be tested with normal electronic instrument like high voltage and high frequency.

Wencon Putty

The quick curing, epoxy moldable repair stick for multi purpose use.

- Cures in 15 minutes
- Simple apply procedure with cut and knead
- Fill out and seal cracks, leaks and holes
- Strong adhesion to all metal surfaces
- Fully machinable

General information

Wencon Putty is a quick curing, two component, epoxy compound supplied in a practical stick format, which is easy to use.

Wencon Putty shares many of the characteristics of metals, which together with a good adhesion to all metallic surfaces makes the repair compound highly suitable for repair of corroded and worn metals.

Wencon Putty is non-conductive and will therefore not cause bi-metallic corrosion. After curing the compound is resistant to oil, water, salt water and most diluted acids and a range of solvents. Heat resistance ranges from 60° C (140°F) in corrosive and heavy load environments and up to 250° (482°F) C when applied as a filling compound.

Application areas

This multi purpose epoxy paste is ideal for wide range of emergency repairs where an ultra quick curing and moldable compound is required. Typical applications are sealing, filling of cracks, leakages and holes in pipes, flanges, tanks etc.

Application

The base and activator is co-extruded into a 125g stick. Cut off the required amount of repair compound, knead it until an even colour is obtained and apply to the damaged area.



cut and knead



Product numbers:

No. 1040	Wencon Putty, 8x125g (8x0,28 lb) unit
No. 1042	Wencon Putty, 4x125g (4x0,28 lb) unit

IMPA no.

812342
812329

ISSA no.

75.553.40
N/A

GENERAL DESCRIPTION

Ultra quick curing two-component, mouldable epoxy repair stick.

SURFACE PREPARATION

The surface must always be clean, dry and grease free.

Improved adhesion can be obtained by grinding or Grit blasting of the surface, prior to application.

APPLYING

ALWAYS WEAR PROTECTIVE GLOVES.

Each stick contains both base and activator. Cut off the required amount and knead it until an even colour is obtained.

After kneading, place the Wencon Putty on the prepared surface and massage or press it into the surface using the fingers.

Heat cold items for better adhesion.

POT LIFE

Depending on amount mixed and temperature. Mixed in small amounts, the pot life is approximately 3-6 minutes at 20°C (68°F)

CURING TIME

Initial setting will take place in 15 minutes and the compound is ready for machining in just 30 minutes.

Wencon Putty obtains full mechanical strength after only 2 hours.

Curing time depends on the temperature and thickness applied. If faster curing is required, heat can be added.

MACHINABLE

After curing, the product can be machined, drilled and worked like metal.

TECHNICAL DATA

Hardness Shore D: 85 (**DIN 53505**)

Tensile strength: 4,6 N/mm² - 655 p.s.i. (**DIN 53454**)

Compressive strength:

Rcrack: 35,14 N/mm² - 5,000 p.s.i. (**DIN 53454**)

Shear adhesion: 4,5 N/mm² - (**ASTM D1002**)

Adhesion to steel: 4,5 N/mm² - (**ISO 4624**)

SPECIFIC VOLUME

500 cm³ per kilogramme (33,9 cu inch/kg)

TEMPERATURE RESISTANCE

Corrosion: 60°C (140° F)

Light load: 120°C (248°F)

As filler: 250°C (482°F)

CHEMICAL RESISTANCE

The compound is resistant to oil, water, salt water and most diluted acids and alkalis as well as a range of solvents.

SHELF LIFE

At 20°C (68°F) : 3 years

HANDLING PRECAUTIONS

Read the Wencon Instruction for Use and the Safety Data Sheet.

Wencon Pipe Tape

The fast curing water activated fibreglass pipe wrap, for a fast and effective repair of cracks, leaks and fractures on pipes carrying water, oil, most gases and even solvents.

- Quick and effective to use
- No mixing – no tools
- Water activated
- Ready for use in 10 seconds – cures in 10 minutes
- Suitable for all pipes and surfaces

General information

Wencon Pipe Tape is a pre-impregnated fibreglass bandage with a knitted non-woven fibreglass structure, that gives the bandage maximum strength and facilitates repairs on corner joints, elbows and other shaped fittings.

The Wencon Pipe Tape is a fast curing pipe repair bandage especially formulated to make quick and effective repairs of cracks, leaks, fractures, and corrosion porosity

Application areas

Typical applications are repairs in piping carrying water, oil, steam, most gases and even solvents. Wencon Pipe Tape has good pressure, temperature and chemical resistance.

Packaging

Wencon Pipe Tape is available in 3 standard sizes;

- 5 cmx150 cm (2x 60 inch.), designed for pipes with an outer diameter of up to 48,3 mm (normal pipe size 1½ inch)
- 5 cmx350 cm, (2x140 inch) designed for pipes with an outer diameter > 48,3 mm up to 88,9 mm (normal pipe size up to 3 inch)
- 10 cmx350 cm (4x140 inch) designed for pipes up to 219,1 mm (8 inch) diameter

The Wencon Pipe Repair Kit contains Wencon Putty, repair bandages and gloves.



Product numbers:		IMPA no.	ISSA no.
No. 1044	Wencon Pipe Tape, 2 units (10cm x350cm) (4x140 inch)	812328	N/A
No. 1045	Wencon Pipe Tape, 5 units (5cm x150cm) (2x60 inch)	812344	75.553.30
No. 1046	Wencon Pipe Tape, 4 units (5cm x350cm) (2x140 inch)	812348	75.553.31
No. 1047	Wencon Pipe Repair Kit, 2 units/ (5cm x150cm) (2x60 inch) + putty (125gr)	N/A	N/A
No. 1048	Wencon Pipe Repair Kit, 5 units/ (5cm x150cm) (2x60 inch)+ putty (125gr)	81XXXX	N/A

GENERAL DESCRIPTION

A preimpregnated fibreglass bandage for repair of cracks, leaks, fractures and corrosion porosity.

SURFACE PREPARATION

Prepare the surface by cleaning and abrading the area surrounding the damage.

Degreasing with Wencon Bio Cleaner will improve adhesion.

MIXING RATIO

No mixing is required

Wencon Pipe Tape is pre impregnated with polyurethane resin and is water activated.

POT LIFE

4-6 minutes depending on air and water temperature.

APPLYING

ALWAYS WEAR PROTECTIVE GLOVES.

Refer to Instructions for use for details application guidance.

1. Select the right Wencon Pipe Tape size.
2. Blast and clean around the damaged area.
3. Soak the tape in water for 10 seconds.
4. Wrap Pipe Tape firmly around pipe min. 9 wraps with 50% overlap.
5. Dip gloves in water and smoothen pipe tape with hands in the direction of wrap until it sets.

Use extra tape for large pipes. No tools needed

CURING TIME

The bandage hardens in 10 minutes and is fully cured within 1 hour at 20°C (68°F)

MACHINABLE

No post curing machining necessary

TECHNICAL DATA

Pipe pressure with Wencon Putty:

50 Bar (725 p.s.i.)

Laboratory tests have shown higher values, but the mentioned values will count for repairs done in situ. Users are advised to make their own tests if any doubt.

Flexural strength: **ASTM D709** 111 N/mm².

Tensile strengt: **ASTM D638** 172 N/mm². (15,800 p.s.i.)

Compression strength: **ASTM D695** 180 N/mmsq. (25,600 p.s.i.)

Adhesion at one-inch single overlap: 19 N/mm².

Dielectric strength: 16 KV/mm²

Shear adhesion: 19 N/mm² (**ASTM D1002**)

TEMPERATURE RESISTANCE

Continuous: 120°C (248°F)

Peak: 190°C (374°F)

CHEMICAL RESISTANCE

The Pipe Tape is resistant to oil, water, salt water and most diluted acids and alkalis as well as a range of solvents.

SHELF LIFE

At 20°C (68°F) : 3 years

HANDLING PRECAUTIONS

Read the Wencon Instruction for Use and the Safety Data Sheet.

Wencon Exhaust Repair kit

The cold weld exhaust repair compound with particularly high temperature resistance.

- Resists temperatures up to 1000° C (1832° F)
- Resists direct flame contact
- Repairs cracks, fills holes and pits
- One component compound – no mixing

General information

Wencon Exhaust Repair is a one-component steel cold weld product that can be used to repair cracks and holes in equipment exposed to temperatures up to 1000° C (1832°F) after full curing.

Wencon Exhaust Repair can be grinded when cured. The compound has good adhesion on all metal surfaces. Wencon Exhaust Repair will not rust or oxidize and is resistant to chemicals.

Application areas

Wencon Exhaust Repair is especially suitable in areas and situations where traditional heat welding cannot be accomplished. Typical applications include engine heads, blocks and manifolds, as well as furnaces and boilers.

Note:

It is important to note, that this product is designed solely for external temporary repairs of cracks and leaks, and it is not recommended for use on aluminium surfaces.

Packaging

The Wencon Exhaust Repair Kit contains:

- Wencon Exhaust Repair Compound, 600g (1,32 lb)
- Reinforcement metal mesh, 10 x 50 cm (4 x 20 inch)
- Spatula
- Application data sheet



Product numbers:

No. 1070 Wencon Exhaust Repair Kit, 600g (1,32 lb)

IMPA no.

812340

ISSA no.

75.553.25

GENERAL DESCRIPTION

One component cold weld repair compound with particularly high temperature resistance.

SURFACE PREPARATION

The surface must always be as clean, dry and degreased.

Improved adhesion can be obtained by grinding or Grit blasting of the surface prior to application.

MIXING RATIO

No mixing is required.

APPLYING

Apply a suitable amount of Exhaust Repair Compound in and around the leak.

Cut reinforcement wire mesh and fix it to the area of the repair. Hold the mesh in place using steel bands or steel wire.

Apply a second layer of the repair compound. Make sure the compound has completely solidified before exposing it to heat, otherwise the curing will not succeed.

CURING TIME

Full curing is recommended at room temperature and curing time depends on application thickness

MACHINABLE

After curing the product can be machined.

SPECIFIC VOLUME

735 cm³ per kilogramme (44,86 cu inch/kg)

TEMPERATURE RESISTANCE

Up to 1000°C (1832°F)

CHEMICAL RESISTANCE

The compound is resistant to oil, water, salt water and alkalis as well as a range of solvents.

SHELF LIFE

At 20°C (68°F) : 3 years

HANDLING PRECAUTIONS

Read the Wencon Instruction for Use and the Safety Data Sheet.

Wencon UW Putty for wet surfaces or under water

The excellent putty for applying on wet surfaces or under water, with a very strong adhesion.

- Can be applied on wet surfaces or under water
- Cures under water and on wet surfaces
- Stop leaking pipes and tanks
- Long pot-life under water
- Strong adhesion to all metal surfaces

General information

Wencon UW Putty is a two-component compound to be applied on wet surfaces or under water. The UW Putty is excellent for filling up holes, dents and rebuilding of surfaces which, due to high humidity, have to be done in wet conditions. Wencon UW Putty is developed for applications, where bigger quantities are needed in one process.

After curing Wencon UW Putty shares many of the same characteristics of metals, which together with outstanding adhesion to all metallic surfaces, makes the compound highly suitable for repair of corroded and worn metal.

Wencon UW Putty is non conductive and will therefore not cause bi-metallic corrosion. After curing Wencon UW Putty is resistant to oil, salt water, most diluted acids and a range of solvents.

Application areas

Typical applications are corroded hulls and all underwater parts of vessels and structures, tanks, pipes, flange faces, etc. Wencon UW Putty is also suitable for filling gaps and holes under water or on wet surfaces, before completion with Wencon UW Cream or UW Coating.

Mixing

Wencon UW Putty has to be mixed above water in the mixing ratio 1:1 by volume.



Product numbers:

No. 1012 Wencon UW Putty, 1 kg (2,2 lb) unit

IMPA no.

812354

ISSA no.

N/A

GENERAL DESCRIPTION

Two-component solvent free pasty consistency epoxy repair compound, for applying under water or on wet surfaces.

SURFACE PREPARATION

Before applying, the surface must be clean from loose paint, scales, under water growth, etc. A mechanical cleaning will do, but even better, if possible, hydro jetting.

APPLYING

Mix the product 1:1 on a mixing plate. Then continue in your hands, wearing wet protection gloves. Mix until the product has an even colour without any "stripes" and press/rub the UW Putty hard against the surface, by hand or by using a spatula.

POT LIFE

Depending on amount mixed and the temperature. Mixed in small amounts, the pot life is approximately 25 minutes at 20°C (68°F)

CURING TIME

Curing will take place in 10-18 hours, but only if the temperature allows it to cure. Curing requires a temperature of at least 10°C (50°F), but better at 17-23°C (62-73°F) or higher.

If the coating shall be exposed to chemicals, let it cure for 7 days before exposure.

REDUCED CURING TIME WITH INFRARED

This product is tested with and suitable for infrared curing. Curing with infrared radiation can reduce curing time significantly. Result can vary, depending on circumstances and equipment used.

MACHINABLE

After curing, the product can be machined, drilled and worked like metal.

TECHNICAL DATA

Hardness Shore D: 76 (**DIN 53505**)

Tensile strength: 17,6 N/mm² - 5094 p.s.i. (**DIN 53454**)

Compressive strength:

Modulus of elasticity: 3400 N/mm² - 375,000 p.s.i. (**DIN 53454**)

Rcrack: 25,3 N/mm² - 19,000 p.s.i. (**DIN 53454**)

Shear adhesion: 15,90 N/mm² - (**ASTM D1002**)

Adhesion to steel: 6,5 N/mm² - (**ISO 4624**)

SPECIFIC VOLUME

556 cm³ per kilogramme (33,9 cu inch/kg)

TEMPERATURE RESISTANCE

Corrosion and heavy load: 60°C (140°F)

Light load or no load: 95°C (203°F)

As filler: 95°C (203°F)

CHEMICAL RESISTANCE

The compound is resistant to oil, water, salt water and most diluted acids and alkalis as well as a range of solvents.

SHELF LIFE

At 20°C (68°F) : 3 years

HANDLING PRECAUTIONS

Read the Wencon Instruction for Use and the Safety Data Sheet.

Wencon UW Cream for wet surfaces or under water

The excellent cream for applying on wet surfaces or under water, with a very good adhesion.

- Can be applied on wet surfaces or under water
- Cures under water and on wet surfaces
- For filling up cavitation damages
- Long pot-life under water
- Strong adhesion to all metal surfaces

General information

Wencon UW Cream is a two-component compound to be applied on wet surfaces or under water. The UW Cream is excellent for filling up holes, dents and rebuilding of surfaces which, due to high humidity, have to be done in wet conditions.

After curing Wencon UW Cream will show many of the same characteristics of metal, together with outstanding adhesion to all metallic surfaces, this makes the compound highly suitable for repair and rebuilding corroded and worn metal surfaces.

Wencon UW Cream is non-conductive and will therefore not cause bi-metallic corrosion. After curing Wencon UW Cream is resistant to oil, salt water, water, most diluted acids and a range of solvents.

Application areas

Typical applications are corroded hulls and all underwater parts of ships and structures, tanks, pipes, flange faces, etc. Wencon UW Cream is also suitable for filling up cavitation damages on hulls and rudders.

Mixing

Wencon UW Cream has to be mixed above water in the mixing ratio 1:2 by volume.



Product numbers:

No. 1014 Wencon UW Cream, 0,5 kg (1,1 lb) unit

IMPA no.

812334

ISSA no.

75.553.91

GENERAL DESCRIPTION

Two-component solvent free pasty consistency epoxy repair compound, for applying under water or on wet surfaces.

SURFACE PREPARATION

Before applying, the surface must be clean from loose paint, scales, under water growth, etc. A mechanical cleaning will do, but even better, if possible, hydro jetting.

MIXING RATIO

Mix by volume 1:2. Mix until an even colour is obtained. The mixing has to take place above water. After mixing, the product can be taken into the water.

POT LIFE

Depending on amount mixed and the temperature. Mixed in small amounts, the pot life is approximately 25-35 minutes at 20°C (68°F)

APPLYING

Wencon UW Cream is applied using the spatula supplied with the kit.

In order to ensure close contact, be sure to work the product well into the surface to be treated.

CURING TIME

Curing will take place in 10-18 hours, but only if the temperature allows it to cure. Curing requires a temperature of at least 10°C (50°F), but better at 17-23°C (62-73°F) or higher.

If the coating shall be exposed to chemicals, let it cure for 7 days before exposure.

REDUCED CURING TIME WITH INFRARED

This product is tested with and suitable for infrared curing. Curing with infrared radiation can reduce curing time significantly. Result can vary, depending on circumstances and equipment used.

MACHINABLE

After curing, the product can be machined, drilled and worked like metal.

TECHNICAL DATA

Hardness Shore D: 79 **(DIN 53505)**

Tensile strength: 35,8 N/mm² - 5094 p.s.i. **(DIN 53454)**

Compressive strength:

Modulus of elasticity: 2631 N/mm² - 375,000 p.s.i. **(DIN 53454)**

Rcrack: 134 N/mm² - 19,000 p.s.i. **(DIN 53454)**

Shear adhesion: 33 N/mm² - **(ASTM D1002)**

Adhesion to steel: 7,5 N/mm² - **(ISO 4624)**

SPECIFIC VOLUME

526 cm³ per kilogramme (32,1 cu inch/kg)

TEMPERATURE RESISTANCE

Corrosion and heavy load: 60°C (140°F)

Light load or no load: 100°C (212°F)

As filler: 160°C (320°F)

CHEMICAL RESISTANCE

The compound is resistant to oil, water, salt water and most diluted acids and alkalis as well as a range of solvents.

SHELF LIFE

At 20°C (68°F) : 3 years

HANDLING PRECAUTIONS

Read the Wencon Instruction for Use and the Safety Data Sheet.

Wencon UW Coating for wet surfaces or under water

Excellent liquid coating for applying on wet surfaces or under water, with a very good adhesion.

- Can be applied on wet surfaces or under water
- Cures under water and on wet surfaces
- Long pot-life under water
- Strong adhesion to all metal and GRE surfaces

General information

The Wencon UW Coating is a two-component product to be applied on wet surfaces or under water. The UW Coating is ideal for repair of ballast- and cooling pipes in together with Wencon reinforcement tape. Wencon UW Coating is developed for repair jobs which due to high humidity have to be done in wet conditions.

After curing, Wencon UW Coating will provide a smooth, non-porous coating, which is resistant to bi-metallic corrosion, light chemical attack, corrosion and impingement. Wencon UW Coating contains no solvents.

Wencon UW Coating is a double coat system and is consequently supplied in two different colours; orange and brown.

Application areas

Typical applications are coatings of steel surfaces rebuild with Wencon UW Cream, and coatings under water - like ships hulls and/ or other submerged structures, tanks, pipes etc. Examples of repairs under extreme conditions could be: on-site repair of sea-water filter housings etc. unable to achieve a dry surface. The UW Coating is also used for scratched painting on hulls in splash-zones and under water.

NB. Cathodic protection systems must be isolated / disconnected and surface allowed to de-polarize before application.

Mixing

Wencon UW Coating has to be mixed above water in the mixing ratio 1:2 by volume.



Product numbers:

No. 1035	Wencon UW Coating, orange, 0,5 kg (1.1 lb) unit
No. 1036	Wencon UW Coating, brown, 0,5 kg (1.1 lb) unit

IMPA no.

812336
812327

ISSA no.

75.553.92
N/A

GENERAL DESCRIPTION

Two-component solvent free liquid coating, for protection against corrosion and bi-metallic corrosion, erosion as well as impingement. The coating can be applied under water.

SURFACE PREPARATION

When applying to an old steel surface under water, the surface must be cleaned for loose paint, scales, under water growth, etc. A mechanical cleaning will do, if possible, use hydro-jetting for the best result.

When Wencon UW coating is applied on top of Wencon UW Cream, it has to be applied when the layer of UW Cream is still tacky.

MIXING RATIO

Mix by volume 1:2. Mix until an even colour is obtained. The mixing has to take place above water. After mixing, the product can be taken into the water.

POT LIFE

Depending on amount mixed and the temperature. Mixed in small amounts, the pot life is approximately 25-35 minutes at 20°C. (68°F)

APPLYING

Wencon UW Coating is applied using a spatula, brush or roller. If the temperature is low – use a brush with short bristles. If the temperature is high, use brush with long bristles. The initial wetting of the brush/roller has to take place above water

OVER COATING

Wencon UW Coating is a double coat system. The over coating time can vary from one to three hours, depending on the temperature. The second layer has to be applied while the first layer is still tacky. The time will vary from 2-6 hours.

CURING TIME

Curing will take place in 10-18 hours, but only if the temperature allows it to cure. Curing requires a temperature of at least 10°C (50°F), but better at 17-23°C (62-73°F) or higher.

If the coating shall be exposed to chemicals, let it cure for 7 days before exposure.

REDUCED CURING TIME WITH INFRARED

This product is tested with and suitable for infrared curing. Curing with infrared radiation can reduce curing time significantly. Result can vary, depending on circumstances and equipment used.

MACHINABLE

After curing, the product can be machined, drilled and worked like metal.

COVERAGE RATE

Approximately 0,8 m². per kg per coat. (0,4 lb/sq. ft)

TECHNICAL DATA

Hardness Shore D: 79 **(DIN 53505)**

Tensile strength: 37,5 N/mm² - 5336 p.s.i. **(DIN 53454)**

Compressive strength:

Modulus of elasticity: 3117 N/mm² - 443,000 p.s.i. **(DIN 53454)**

Rcrack: 133 N/mm² - 19,000 p.s.i. **(DIN -53454)**

Shear adhesion: 31,90 N/mm² - **(ASTM D1002)**

Adhesion to steel: 7,5 N/mm² - **(ISO 4624)**

SPECIFIC VOLUME

535 cm³ per kilogramme (32,6 cu inch/kg)

TEMPERATURE RESISTANCE

Corrosion or heavy load: 60°C (140°F)

Light or no load: 100°C (212°F)

As filling compound: up to 160°C (320°F)

CHEMICAL RESISTANCE

The coating is resistant to oil, water, salt water and most diluted acids and alkalis as well as a range of solvents.

SHELF LIFE

At 20°C (68°F) : 3 years

HANDLING PRECAUTIONS

Read the Wencon Instruction for Use and the Safety Data Sheet.

Wencon UW Coating (Low Viscosity)

An excellent liquid coating for spray and brush applications.

- Convenient spray functionality
- Can be applied on dry or wet surfaces by brush
- Cures underwater and on wet surfaces
- Strong adhesion to all metal surfaces
- Compatible with GRE, composites and concrete

General information

The Wencon UW Coating LV is essentially identical to Wencon UW Coating. Its low viscosity allows it to be presented in cartridges, providing the following advantages:

- Spray application
- Injection
- Direct Hose/Brush application
- Smooth automatic mixing

The two-component product mixes directly in the static mixer nozzle, ensuring an optimal mixed product ready for application. The UW Coating LV is significantly faster compared to traditional packs that require manual mixing and brush application.

Once cured, Wencon UW Coating LV provides a smooth, non-porous coating resistant to bi-metallic corrosion, light chemical attack, corrosion, and impingement.

Wencon UW Coating LV, contains no solvents.

Application areas

Specially designed for larger application areas, typical applications include coatings for steel, composite, and GRE surfaces.

Bringing repair and maintenance solutions for, but not limited to, scrubber overboard outlet, sea water strainer, rudder blades, bow thruster or tanks for example.

NB. Cathodic protection systems must be isolated/disconnected, and surfaces must be allowed to depolarize before application.

Mixing

Mix by volume 2:1. The product is mixed by the static mixer when dispensed from the cartridges.



Product numbers:

No. 4550 Wencon UW Coating LV. 1,125ML unit

IMPA no.

N/A

ISSA no.

N/A

GENERAL DESCRIPTION

Two-component, solvent-free liquid coating for protection against corrosion, bi-metallic corrosion, erosion, and impingement. The coating can be applied on wet surfaces.

SURFACE PREPARATION

Optimal: We recommend that the surface preparation prior to the application complies with ISO 8501 or a comparable quality certification to ensure the desired level of quality is achieved.

Minimum: Before applying, the surface must be clean from loose paint, scales, underwater growth, etc. Mechanical cleaning is sufficient, but hydro-jetting is preferred where possible.

MIXING RATIO

Mix by volume 2:1. The product will be automatically mixed by the static mixer when dispensed from the cartridges.

POT LIFE

Depending on the amount mixed and the temperature, the pot life varies. When mixed in small amounts at 20°C (68°F), the pot life is approximately 25-35 minutes.

If preheated to 35°C (95°F), the pot life of Wencon UW LV will be 3 to 5 minutes.

APPLYING

Wencon UW Coating LV can be applied using traditional spatula, brush or roller.

When using a pneumatic dispenser and accessories, it can be sprayed, injected or brushed directly from the cartridges.

OVER COATING

If a double layer is required, the overcoating time may range from 1 to 3 hours, depending on the temperature. It is important to apply the second layer while the first layer is still tacky, which typically takes between 2 to 6 hours.

CURING TIME

Curing will occur within 10-18 hours at 20°C (68°F).

If the coating is to be exposed to chemicals, allow it to cure for 7 days before exposure.

REDUCED CURING TIME WITH INFRARED

This product has been tested with and is suitable for infrared curing. Curing with infrared radiation can significantly reduce curing time.

MACHINABLE

After curing, the product can be machined, drilled, and worked similar to metal.

COVERAGE RATE

Approximately 0.8 m² per kg per coat.
(0.4 lb/sq. ft)

TECHNICAL DATA

Hardness Shore D: 80 (DIN 53505)

Tensile strength: 37 N/mm² 5366 p.s.i.

Compressive strength: Modulus of elasticity: 3282 N/mm² - 476000 p.s.i.(DIN 53454)

Rcrack: 130 N/mm² -19000 p.s.i.(DIN 53454)

Shear adhesion: 31,1 N/mm² - 45106 p.s.i. (ASTM D1002)

Adhesion to steel: 7,5 N/mm² - 10877 p.s.i. (ISO 4624)

SPECIFIC VOLUME

524 cm³ per kilogram (32,6 cubic inches/kg)

TEMPERATURE RESISTANCE

Corrosion or heavy load: 60°C (140°F)

Light or no load: 100°C (212°F)

As filling compound: up to 160°C (320°F)

CHEMICAL RESISTANCE

The coating is resistant to oil, water, saltwater, most diluted acids and alkalis, as well as a range of solvents. Please refer to the chemical resistance list.

FIRE RESISTANCE

Tested according to IMO Resolution MSC 307(88)(2010 FTP Code) Annex1: Part 2 and 5

SALT SPRAY TEST

Tested according to ISO12944-9

SHELF LIFE

At 20°C (68°F) : 3 years

HANDLING PRECAUTIONS

Read the Wencon Instruction for Use and the Safety Data Sheet.

Wencon Ceramic Cream

The epoxy compound for repair and rebuilding of deteriorated metal parts, exposed to excessive wear.

- High wear resistance
- High temperature resistance
- Strong adhesion to all metal surfaces
- Easy mixing and application
- High abrasion resistance

General information

Wencon Ceramic Cream is a basic two-component, epoxy compound suitable for a wide range of applications. The compound is used for repair and rebuilding of worn, damaged, cracked and corroded metal parts.

Wencon Ceramic Cream shows many of the same characteristics of metal, which together with outstanding adhesion to all metallic surfaces makes the repair compound highly suitable for repair of corroded and worn metals.

Wencon Ceramic Cream is non conductive and will therefore not cause bi-metallic corrosion. After curing the compound is resistant to oil, water, salt water and most diluted acids and a range of solvents. Heat resistance ranges from 200° C (392° F) in corrosive and heavy load environments and up to 300° C (572°F) when applied as a filling compound.

Application areas

Wencon Ceramic Cream has a high abrasion resistance, making it suitable for applications on propeller nozzles, rudders, thruster tunnels and housings. In addition, the product also offer high temperature resistance, which makes it ideal for applications on gas scrubbers, condensers and end-covers.

Mixing

Wencon products are designed to be simple to use and cost effective. Easy mixing ratios (1:2 by volume) reduce waste to a minimum and high specific volume gives high coverage rates.



Product numbers:

No. 1016 Wencon Ceramic Cream, 1 kg (2,2 lb) unit

IMPA no.

812592

ISSA no.

N/A

GENERAL DESCRIPTION

Two-component solvent free paste consistency epoxy repair compound for rebuilding of deteriorated metal parts, exposed to excessive wear.

SURFACE PREPARATION

The surface must always be dry, clean and degreased

Applying to new steel surface:

- Grit blasting to SA 2,5
- if Grit blasting is not possible use grinding
- After grinding the surface must be degreased with Wencon Bio Cleaner

Repairing old steel surface:

- Grit blasting to SA 2,5
- Sweat out water and salts
- Grit blasting to SA 2,5 again
- Profile Rz 75-110 microns

MIXING RATIO

Mix by volume 1:2. Mix until an even colour is obtained.

POT LIFE

Depending on amount mixed and temperature. Mixed in small amounts, the pot life is approximately 30-40 minutes at 20°C (68°F)

APPLYING

Wencon Ceramic Cream has a paste consistency and is applied by spatula.

CURING TIME

Curing will take place in 10-15 hours at 20°C (68°F)

REDUCED CURING TIME WITH INFRARED

This product is tested with and suitable for infrared curing. Curing with infrared radiation can reduce curing time significantly. Result can vary, depending on circumstances and equipment used.

MACHINABLE

After curing, the product can be machined, drilled and worked like metal.

TECHNICAL DATA

Hardness Shore D: 80 (**DIN 53505**)

Tensile strength: 25,8 N/mm² - 3671 p.s.i. (**DIN 53454**)

Compressive strength:

Modulus of elasticity: 2799 N/mm² - 398.000 p.s.i. (**DIN 53454**)

Rcrack: 65 N/mm² - 9.500 p.s.i. (**DIN 53454**)

Shear adhesion: 30,80 N/mm² - (**ASTM D1002**)

Adhesion to steel: 6,7 N/mm² - (**ISO 4624**)

Abrasion Resistance (Taber wear test): 25.6 (**ISO 7784-1**)

SPECIFIC VOLUME

538 cm³ per kilogramme (32,8 cu inch/kg)

TEMPERATURE RESISTANCE

Corrosion: 200°C (392° F)

Light load: 250°C (482°F)

As filler: 300°C (572°F)

CHEMICAL RESISTANCE

The compound is resistant to oil, water, salt water and most diluted acids and alkalis as well as a range of solvents.

SHELF LIFE

At 20°C (68°F) : 3 years

HANDLING PRECAUTIONS

Read the Wencon Instruction for Use and the Safety Data Sheet.

Wencon Ceramic Coating

The versatile and cost effective coating product for general repair, maintenance and protection of surfaces, exposed to excessive wear.

- High wear resistance
- High temperature resistance
- Strong adhesion to all metal surfaces
- Efficient double coat system
- High coverage rate

General information

Wencon Ceramic Coating is a two-component, liquid epoxy coating suitable for a wide range of applications. It provides a smooth non porous surface, which is resistant to bi-metallic corrosion, light chemical aggression, corrosion and erosion as well as impingement.

Wencon Ceramic Coating offers resistance to oil, water, salt water and most diluted acids and alkalis as well as a range of solvents. Heat resistance ranges from 220° C (428°F) in corrosive and heavy load environments and up to 320° C (608°F) when applied as a filling compound.

Application areas

Wencon Ceramic Coating has a high abrasion resistance, making it suitable for applications on propeller nozzles, rudders, thruster tunnels and housings. Typical applications are coating of surfaces rebuild after deterioration and protection against wear, corrosion and bi-metallic corrosions. In addition, the product also offer high temperature resistance, which makes it ideal for applications on gas scrubbers, condensers and end-covers.

Wencon Ceramic Coating is a double coat system and is consequently supplied in two different colours, light grey and light green.

Mixing

The Wencon products are designed to be simple to use and cost effective. Easy mixing ratio (1:2 by volume) reduce waste to a minimum and high specific volume gives high coverage rates.



Product numbers:

No. 1017	Wencon Ceramic Coating, light grey - 0,5 kg (1,1 lb)
No. 1018	Wencon Ceramic Coating, light green - 0,5 kg (1,1 lb)

IMPA no.

812593
812594

ISSA no.

N/A
N/A

GENERAL DESCRIPTION

Two-component solvent free liquid epoxy coating for general repair, maintenance and protection of surfaces exposed to excessive wear.

SURFACE PREPARATION

The surface must always be dry, clean and degreased

Applying to new steel surface:

- Grit blasting to SA 2,5
- Profile 75 microns

Repairing old steel surface:

- Grit blasting to SA 2,5
- Sweat out water and salts
- Profile Rz 75-110 microns

MIXING RATIO

Mix by volume 1:2. Mix until an even colour is obtained.

POT LIFE

Depending on amount mixed and temperature. Mixed in small amounts, the pot life is approximately 20-30 minutes at 20°C (68°F)

APPLYING

Wencon Ceramic Coating is liquid and is applied by brush, roller or spatula.

OVER COATING

Wencon Ceramic Coating is a double coat system. The over coating time can vary from one to three hours depending on temperature. The second coat must be applied whilst the first coat is still tacky. If full curing has occurred a light sandblasting or grinding is necessary prior to the second coat.

CURING TIME

Curing will take place in 10-15 hours at 20°C (68°F)

MACHINABLE

After curing, the product can be machined, drilled and worked like metal.

REDUCED CURING TIME WITH INFRARED

This product is tested with and suitable for infrared curing. Curing with infrared radiation can reduce curing time significantly. Result can vary, depending on circumstances and equipment used.

COVERAGE RATE

Theoretical: 0,91 kg per m² (0,19 lb/sq. ft.) at 600 microns

Practical: 1,2 kg per m² (0,25 lb/sq. ft.)

TECHNICAL DATA

Hardness Shore D: 81

Tensile strength: 25,4 N/mm² - 3614 p.s.i. **(DIN 53454)**

Compressive strength

Modulus of elasticity: 3030 N/mm² - 431,000 p.s.i. **(DIN 53454)**

Rcrack: 124 N/mm² - 18,000 p.s.i. **(DIN 53454)**

Shear adhesion: 28,90 N/mm² - **(ASTM D1002)**

Adhesion to steel: 4,5 N/mm² - **(ISO 4624)**

Abrasion Resistance (Taber wear test): 21.9 **(ISO 7784-1)**

SPECIFIC VOLUME

658 cm³ per kilogramme (40,2 cu inch/kg)

TEMPERATURE RESISTANCE

Corrosion: 220°C (428°F)

Light load: 260°C (500°F)

As filler: 320°C (608°F)

CHEMICAL RESISTANCE

The compound is resistant to oil, water, salt water and most diluted acids and alkalis as well as a range of solvents.

SHELF LIFE

At 20°C (68°F) : 3 years

HANDLING PRECAUTIONS

Read the Wencon Instruction for Use and the Safety Data Sheet.

Wencon Accessories

The complementary range of products and all necessary tools for a successful application.

Wencon Cleaner

Wencon Bio Cleaner

Wencon Release Agent

Wencon Reinforcement Tape

Wencon Application Tools

Wencon Accessories are high quality products carefully selected and designed to contribute to make your repair application successful. During a temporary on-board repair, or when planning a scheduled repair or maintenance job, it is important to make sure that you have all the necessary components, tools and aids required at hand, before you start.

The application data sheet in the Wencon Repair Manual clearly lists all the products required for the individual application.

The tetrachloroethylene based degreaser (**Wencon Cleaner**) and the water based degreaser (**Wencon Bio Cleaner**) which is an environmentally friendly product, ensuring you the best possible adhesion to the surface.

The greasy cream (**Wencon Release Agent**) which ensures that the compound or coating does not adhere, where it is not suppose to. Sometimes it is necessary to strengthen the repair, by combining the repair compound or coating with a bandage (**Wencon Reinforcement Tape**)

Having the right tools for mixing and applying (**Wencon Application Tools**) will also contribute to a quick and successful repair application.



Product numbers:

		IMPA no.	ISSA no.
No. 1100	Wencon Cleaner, 0,5 litre unit	812349	75.553.01
No. 1104	Wencon Bio Cleaner, 0,75 litre unit	812597	N/A
No. 1110	Wencon Release Agent, 50 g unit (0,07 lb)	812350	75.553.60
No. 1120	Wencon Reinforcement Tape 5cm x 10m (400 inch)	812339	75,533,50
No. 1122	Wencon Reinforcement Tape 10cm x 20m (800 inch)	N/A	N/A
No. 2805	Wencon Application Tools	812595	75.553.80

WENCON CLEANER

General description

Wencon Cleaner is a tetrachloroethylene based degreasing agent, which is used for cleaning purposes prior to application of the Wencon repair compounds and coatings.

Handling precautions

Wencon Cleaner is non-flammable. Use only in large or well ventilated rooms.

Read the Wencon Instruction for Use and the Safety Data Sheet.

WENCON BIO CLEANER

General description

Wencon Bio Cleaner is a water based alkaline degreaser, which is used for cleaning purposes prior to application of Wencon products.

Wencon Bio Cleaner is an environmentally friendly product which can be applied on wet or dry surfaces.

WENCON REINFORCEMENT TAPE

General description

Wencon Reinforcement Tape is a flexible fibre tape used for reinforcing repairs made with Wencon compounds and coatings.

Typical applications include pipe repairs, cracks or holes in engine blocks, oil sumps, etc.

WENCON RELEASE AGENT

General description

Wencon Release agent is used in applications where you need to prevent adhesion between the Wencon repair compound, Coating or Putty and the surface.

WENCON APPLICATION TOOLS

General description

Wencon Application Tools are quality products used when mixing and in relation to the application of Wencon repair compounds and coatings.

The kit contains:

4 x Spatulas for application of compounds and coatings.

4 x Brushes for application of coatings.

4 x Mixing knives for mixing of Wencon two component.

1 x Pair of scissors for cutting Wencon Reinforcement Tape, Pipe Tape and other soft material.

4 x Pairs of nitrite-gloves.

Rotating Blaster

The Rotating Blaster disc is a product for removal of rust, epoxy, layers of dirt, paint, glue etc.

- Excellent surface preparation
- Needle hammering with electric drill
- Best alternative to blasting
- Easy to use
- Long durability/service life

General information

Rotating Blaster is a rotating disc for removal of rust, dirt, paint, epoxy etc. from various materials, such as steel, iron, metals, stone and concrete.

Rotating Blaster is a rubber disc with 12 steel pins vulcanised inside, with an axle in the middle, for use in a hand drilling machine. The steel pins are made of special hard metal, mounted with conical shape. The disc is made of 96% natural rubber and is therefore very flexible. When the disc is rotating the pins are moving in different directions and the pins will hammer directly on the surface.

In situations where shot blasting is not possible, the Rotating Blaster is an alternative method for surface preparation. The blaster will leave the treated surface with a texture suitable for the application of a new protective coating. The hammer effect creates no heat, so tough materials such as tar, adhesives and sealants will be easily removed.

Packaging

The Rotating Blaster discs are available as double and triple discs for hand drilling machines.



Product numbers:

No. 1252	Rotating Blaster Double
No. 1254	Rotating Blaster Triple

IMPA no.

N/A
N/A

ISSA no.

N/A
N/A

GENERAL DESCRIPTION

Rotating Blaster disc for removal of rust, dirt, paint and epoxy from materials, such as; steel, iron, metal, stone and concrete.

SIZE

Disc Diameter : 126 mm + / - 0.8mm

Disc Thickness : 6.7 mm + / - 0.3mm

Stud Record : 8 mm

MATERIAL

Rubber : Natural rubber with binder and 50 Shore A hardness.

Tungsted Carbide/Hard Metal: Hardness 1500HV

USE AND SAFETY

- ALWAYS wear safety goggles, working gloves, dust mask and protective clothing
- Maximum speed 4000 rpm
- Recommended speed between 2500 and 3000 rpm; DIRECTION = clockwise. At a lower rpm the effect will be less, but the disc will then become more flexible and gives the opportunity to reach difficult places like corners. In this situation 1200 rpm is recommended.
- Disc should never be used on: edges, raised surfaces etc.

Product numbers:

No. 1252 Rotating Blaster Double
No. 1254 Rotating Blaster Triple

IMPA no.

N/A
N/A

ISSA no.

N/A
N/A

Wencon Repair Kits



Minimize downtime and maintain safety with Wencon Repair Kits - complete, practical solutions for fast and durable repairs on pipes, tanks, and surfaces made of steel and GRE. Easy and safe to apply, even under harsh offshore conditions, our kits ensure efficient maintenance and reliable performance ideal for both preventive and emergency repairs.

Repair examples	Kit name	Steel Pipe/Plate & GRE Repair	Steel Pipe Repair 1 Ø150-250mm.	Steel Pipe Repair 2 Ø<150mm.	GRE Pipe Repair Ø<250-750mm.	SW Strainer/ Filter Housing Rep
		IMPA No: 812341 Product No: 8750	IMPA No: 812331 Product No: 8751	IMPA No: 812332 Product No: 8752	IMPA No: 812333 Product No: 8753	IMPA No: 812326 Product No: 8754
Steel pipe DN 32 , repair length 300 mm. With Putty, Rapid and 3 layers of Reinforcement tape (0,05x10m)		16 pcs	16 pcs	8 pcs		
Steel pipe DN 100 , repair length 300 mm. With Putty, Rapid and 3 layers of Reinforcement tape (0,05x10m)		7 pcs	6 pcs	3 pcs		
Steel pipe DN 150 , repair length 300 mm. With Putty, Cream and 3 layers of Reinforcement tape (0,05x10m)		2 pcs	4 pcs			
Steel pipe DN 250 , repair length 300 mm. With Putty, Cream and 3 layers of Reinforcement tape (0,05x10m)		1 pcs	2 pcs			
Steel pipe DN 32 , Ø5 mm. damage. Repair length 105 mm. With Putty and Pipe tape 0,05x1,5m.		5 pcs		2 pcs		
Steel pipe DN 100 , Ø5 mm damage. Repair length 105 mm. With Putty and Pipe tape 0,05 x 1,5 m		1 pcs		3 pcs		
Steel Pipe DN 150 , Ø5mm damage. Repair length 105mm. With Putty and Pipe tape 0,05x3,5m.		2 pcs	2 pcs			
Steel pipe DN 200 , Ø5mm damage. Repair length 105 mm. With Putty and Pipe tape 0,1 x 3,5 m		1 pcs	1 pcs			
Heating coils DN 50 , repair length 1600 mm. Hi-Temp coating and 3 layers of Reinforcement tape (0,05x10m)		1 pcs		1 pcs		
FW HT pipe with Hi-Temp coating		✓		✓		
GRE pipe DN 125 , repair length 500 mm. With UW coating and 3 layers of Reinforcement tape (0,05x10m)		1 pcs			7 pcs	
GRE pipe DN 750 , repair length 500 mm. With UW coating and 3 layers of Reinforcement tape (0,05x10m)					1 pcs	
Repair of SW strainer/filter housing, with Cream and Coating		1.2 m ²	2.0 m ²	1.0 m ²		3.0 m ²
Pump well with UW cream and UW coating, 2 layers of 500 µ each		0.44 m ²				
Repair of cracked paint under water or at oil polluted surfaces. UW coating, 2 layers of 500 µ each		0.44 m ²			3.1 m ²	
Putty 5000 µ (for repair of penetrated holes)		0.1 m ²	0.1 m ²	0.1 m ²		0.1 m ²
Cream 2000 µ (for building up surface)		0.3 m ²	0.9 m ²			0.9 m ²
Coating White (first layer of coating)		2.0 m ²	2.0 m ²	1.0 m ²		3.0 m ²
Coating Blue (second layer of coating)		2.0 m ²	2.0 m ²	1.0 m ²		3.0 m ²

V 2.2 March. 2026

Product numbers:		IMPA no.	ISSA no.
No. 8750	Steel Pipe/Plate & GRE Repair	812341	N/A
No. 8751	Steel Pipe Repair 1 Ø150-250 mm.	812331	N/A
No. 8752	Steel Pipe Repair 2 Ø<150 mm.	812332	N/A
No. 8753	GRE Pipe Repair Ø<250-750 mm.	812333	N/A
No. 8754	SW Strainer/Filter Housing Rep	812326	N/A

No. 1010	Wencon Cream, 1kg unit	IMPA No. 812335	ISSA No. 75.553.20
Wencon Cream is a basic two-component, epoxy compound with a wide range of applications for repair and rebuilding of worn, damaged, cracked and corroded machine and metal parts. Typical applications are corroded tanks, pump housings, impellers, valves, pipes, flange faces, roller bearing seats, worn shafts, hydraulic rams and heat exchangers.			
No. 1000	Wencon Rapid, 1kg unit	IMPA No. 812347	ISSA No. 75.553.21
No. 1005	Wencon Rapid 8, 8x125g unit	IMPA No. 812343	ISSA No. 75.553.22
Wencon Rapid is a fast curing, two-component, epoxy compound with a wide range of applications for emergency repairs and maintenance. Typical applications as for Wencon Cream.			
No. 1020	Wencon Coating, white, 0,5kg unit	IMPA No. 812337	ISSA No. 75.553.10
No. 1030	Wencon Coating, blue, 0,5kg unit	IMPA No. 812338	ISSA No. 75.553.11
Wencon Coating is a two-component, liquid epoxy coating suitable for a wide range of applications. Typical applications are coating of surfaces rebuilt after deterioration, protection of tanks, pumps, valves, wet liners, cooler end covers etc. against corrosion and bi-metallic corrosion.			
No. 1050	Wencon Hi-Temp, yellow, 0,5kg unit	IMPA No. 812345	ISSA No. 75.553.12
No. 1060	Wencon Hi-Temp, green, 0,5kg unit	IMPA No. 812346	ISSA No. 75.553.13
Wencon Hi-Temp is a high performance two-component, liquid epoxy coating developed for applications in high load areas.			
No. 1040	Wencon Putty, 8x125 g unit	IMPA No. 812342	ISSA No. 75.553.40
No. 1042	Wencon Putty, 4x125g unit	IMPA No. 812329	ISSA No. N/A
Wencon Putty is a very quick curing, two-component, epoxy compound supplied in a practical and easy to use stick format. This multi purpose epoxy paste is ideal for wide range of emergency repairs where an ultra quick curing and mouldable compound is required.			
No. 1044	Wencon Pipe Tape, 2 units (10cmx350 cm)	IMPA No. 812328	ISSA No. N/A
No. 1045	Wencon Pipe Tape, 5 units (5cmx150 cm)	IMPA No. 812344	ISSA No. 75.553.30
No. 1046	Wencon Pipe Tape, 4 units (5cmx350 cm)	IMPA No. 812348	ISSA No. 75.553.31
Wencon Pipe Tape is a fast curing pipe repair bandage especially formulated to make quick and effective repairs of cracks, leaks, fractures, and corrosion porosity in piping carrying water, oil, steam, most gases and even solvents.			
No. 1070	Wencon Exhaust Repair Kit, 600g	IMPA No. 812340	ISSA No. 75.553.25
Wencon Exhaust Repair is a one component steel cold weld product that can be used to repair cracks and holes in equipment that is exposed to temperatures up to 1000° C. Typical applications include engine heads, blocks and manifolds, as well as furnaces and boilers.			
No. 1014	Wencon UW Cream, 0,5kg unit	IMPA No. 812334	ISSA No. 75.553.91
Special epoxy based cream for applying under water or direct on wet surfaces.			
No. 1035	Wencon UW Coating, orange, 0,5kg unit	IMPA No. 812336	ISSA No. 75.553.92
No. 1036	Wencon UW Coating, brown, 0,5kg unit	IMPA No. 812327	ISSA No. N/A
No. 4550	Wencon UW Coating LV, 1,125ML unit	IMPA No. N/A	ISSA No. N/A
Special epoxy based coating for applications under water, below dew point or directly on wet surfaces.			
No. 1012	Wencon UW Putty, 1 kg unit	IMPA No. 212354	ISSA No. N/A
Special epoxy based compound for applications under water, below dew point or directly on wet surfaces.			
No. 1016	Wencon Ceramic Cream, 1kg unit	IMPA No. 812592	ISSA No. N/A
Epoxy compound for repair and rebuilding of deteriorated metal parts exposed to excessive wear			
No. 1017	Wencon Ceramic Coating light grey, 0,5kg	IMPA No. 812593	ISSA No. N/A
No. 1018	Wencon Ceramic Coating light green, 0,5kg	IMPA No. 812594	ISSA No. N/A
The cost effective coating product for general repair, maintenance and protection of surfaces exposed to excessive wear.			
No. 1100	Wencon Cleaner, 0,5 litre unit	IMPA No. 812349	ISSA No. 75.553.01
Degreasing agent, used prior to application of epoxy compounds and coatings.			
No. 1104	Wencon Bio Cleaner, 0,75 litre unit	IMPA No. 812597	ISSA No. N/A
Environmental friendly degreasing agent, used prior to application of epoxy compounds and coatings.			
No. 1110	Wencon Release Agent, 50g unit	IMPA No. 812350	ISSA No. 75.553.60
Special grease used to prevent adhesion of epoxy compounds and coatings.			
No. 1120	Wencon Reinforcement Tape, 5cm x 10m	IMPA No. 812339	ISSA No. 75.553.50
No. 1122	Wencon Reinforcement Tape, 10cm x 20m	IMPA No. N/A	ISSA No. N/A
Fibre tape used for reinforcing repairs made with epoxy compounds and coatings.			
Silica carbide based granulates for non-slip surfacing and wear resistant coating applications.			
No. 2805	Wencon Application Tools	IMPA No. 812595	ISSA No. 75.553.80
Selection of tools for use when mixing and applying of Wencon repair products.			

Index - Chapter 2

General application specification	35
Wencon Cream	37
Wencon Rapid	38
Wencon Coating	39
Wencon Hi-Temp	40
Wencon Putty	41
Wencon Pipe Tape	42
Wencon Exhaust Repair Kit	44
Wencon UW Putty for wet surfaces or under water	45
Wencon UW Cream for wet surfaces or under water	46
Wencon UW Coating for wet surfaces or under water	47
Wencon UW Coating (Low Viscosity)	48
Wencon Ceramic Cream	50
Wencon Ceramic Coating	51
Wencon Rotating Blaster	52
Wencon Cleaner	53
Wencon Reinforcement Tape	54
Wencon Release Agent	55

General application specification

General specification for use of Wencon products for refurbishing and/or preserving metal structures.

Wencon products are used for refurbishing and/or preventive coating of pumps, valves, coolers, heat exchangers, pipes, tanks, filters, strainers, etc. (Chapter 5 in the WENCON Manual).

The system is built in three layers. First layer is the actual rebuilding of the deteriorated surface Fig. 1. If the machine part is new, you can leave out this first layer. The next two layers consist of a coating that shall prevent the substrate from being deteriorated again in the near future. Normal paint will protect metal surfaces for a few months, the Wencon coatings will protect for many years. Fig. 2 and 3.

First layer

First layer is applied in order to retain the original thickness and/or shape of the surface of the deteriorated machine part. The actual product, used for this application depends on the situation. Basically there are three options: Wencon Cream, for standard applications, Wencon UW Cream for under water applications and Wencon Ceramic Cream for abrasion resistant applications.

Second and third layer

The two layers of coating, that shall be applied wet in wet, just after the previous layer has semi cured, but still tacky, shall be chosen among the variety of Wencon Coatings. The parameters that helps you choose, will be temperature, above or under water, abrasion condition, chemical condition, spray or brush applying, etc. Use the Wencon Manual to find the right Coating for the job, or ask your Wencon representative.

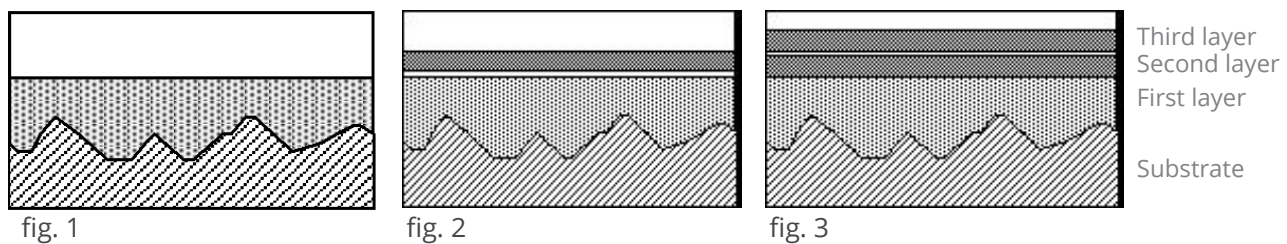

Surface preparation acc. to ISO 12944

Before any application can take place, the surface must be prepared. The adhesion of the chosen Wencon product depends on the surface preparation. However, the situation indicates what is possible and what is needed. Here will be given the full range of the surface preparation.

Grit blasting. Grit blast the area to be treated to min. SA 2,5 acc. to ISO 12944. Test the surface for salt content acc. to ISO 12944. Remove salt if any. Round any sharp edges to radius 3 mm. Apply heat if item is too cold to stay dry during the operation (see: conditions for application below). Repeat the shot blasting to min. SA 2,5 with a sharp profile of min. 75 μ acc. to ISO 12944.

Conditions for application

The temperature of the item and the climatic conditions must be prepared, so the surface at any time, during the application and curing of Wencon products, is min. 3 degrees above dew point, acc. to ISO 12944.

Apply the chosen Wencon products according to the specification and the Instructions for use.

Quality control

Each application must be tested after curing, in order to examine the quality of the job. Even small failures, may have effect on the result of the job.

Visual check

Check carefully for visual defects, areas, where the last coat is missing, or the like.

Thickness test

In order to verify, that the minimum required layer thickness is obtained, a NDT test shall be carried out with a thickness tester. This to indicate the total thickness of the Wencon layers. In some areas, the tester may not show a value. The reason for that, might be that the total thickness of the Wencon products exceeds the measuring capacity of the measuring equipment.

Pore test

A pore test will reveal weak spots in the coating, most often arising from air entrapment in the coating. Basically, there are two types of pore testers, low voltage, wet sponge equipment, and high voltage metal brush equipment.

Adhesion test

A Dyna pull test (ISO 12944) can be made to control the adhesion of the Wencon system used.

Wencon Cream

General Description	<p>Wencon Cream is a two-component compound. After curing, Wencon Cream will exhibit a wide range of the characteristics of metals, which together with outstanding adhesion to all metallic surfaces, makes the compound highly suitable for repair of corroded and worn metal. Wencon Cream is non conducting and will therefore not cause bi-metallic corrosion.</p> <p>Typical applications are corroded tanks, pump housings and impellers, valves, tubes, pipes, heat exchangers, flange faces, roller bearing seats, worn shafts, hydraulic rams, keyways, etc. It is also excellent as a filling compound.</p>						
Surface Preparation	<p>Before applying, the surface must be clean. If possible shot blasted to Swedish Standard SA 2 1/2. Where impregnation of oil or salt is possible, the item is either left for 10-20 hours or heated to 30-40°C (86-104°F) in order to sweat out the oil or salt. Then the shot blasting is repeated. In some applications sandblasting is not possible and thorough grinding must take place to clean metal.</p> <p>N.B. Steel brushing is not advisable as it gives a smooth surface. After grinding Wencon Bio Cleaner is used for degreasing.</p>						
Mixing Ratio	Mixing ratio 1:1 by volume. Mix until even colour is obtained.						
Pot Life	30 - 60 minutes at 20°C (68°F), depending on amount.						
Applying	Wencon Cream is applied using the spatula supplied with the kit.						
Curing	Curing time depends on the temperature and the thickness applied. At 20°C (68°F) 10 -15 hours. If faster curing is required, heat can be added. At 100°C (212°F) curing time is reduced to 15-20 minutes.						
Machinability	After curing, Wencon Cream can be machined, drilled and worked like metal.						
Chemical Resistance	After curing, Wencon Cream will be resistant to oil, water, salt water, most diluted acids and a range of solvents.						
Temperatur Resistance	<table border="0" style="width: 100%;"> <tr> <td style="padding-right: 20px;">Corrosion and heavy load:</td> <td>60°C (140°F)</td> </tr> <tr> <td>Light or no load:</td> <td>120°C (248°F)</td> </tr> <tr> <td>As filling compound</td> <td>up to 250°C (482°F)</td> </tr> </table>	Corrosion and heavy load:	60°C (140°F)	Light or no load:	120°C (248°F)	As filling compound	up to 250°C (482°F)
Corrosion and heavy load:	60°C (140°F)						
Light or no load:	120°C (248°F)						
As filling compound	up to 250°C (482°F)						
Specific Volume	775 cm ³ /kg (49,5 cu inch/kg)						
Hardness	Shore D 75.						
Handling Precautions	Read the instructions on the packaging and the Safety Data Sheet.						

Wencon Rapid

General Description	<p>Wencon Rapid is a fast curing, two-component compound. After curing, Wencon Rapid will exhibit a wide range of the characteristics of metals, which together with outstanding adhesion to all metallic surfaces, makes the compound highly suitable for repair of corroded and worn metal. Wencon Rapid is non conducting and will therefore not cause bi-metallic corrosion.</p> <p>Wencon Rapid is very suitable for applications where thicker layers of material are required, as the compound quickly sets and becomes solid. Typical applications are corroded tanks, pump housings and impellers, valves, tubes, pipes, heat exchangers, flange faces, seats, worn shafts, hydraulic rams and all emergency repairs, where a short curing time is required.</p>						
Surface Preparation	<p>Before applying, the surface must be clean. If possible grit blasted to Swedish Standard SA 2 1/2. Where impregnation of oil or salt is possible, the item is either left for 10-20 hours or heated to 30-40°C (86-104°F) in order to sweat out the oil or salt. Then the sandblasting is repeated. In some applications sandblasting is not possible and thorough grinding must take place to clean metal.</p> <p>N.B. Steel brushing is not advisable as it gives a smooth surface. After grinding Wencon Bio Cleaner is used for degreasing.</p>						
Mixing Ratio	Mixing ratio 1:1 by volume. Mix until even color is obtained.						
Pot Life	10-20 minutes at 20°C (68°F), depending on amount.						
Applying	Wencon Rapid is applied using the spatula supplied with the kit.						
Curing	Curing time depends on the temperature and the thickness applied. At 20°C (68°F) 40-90 minutes. If faster curing is required, heat can be added. At 100°C (212°F) curing time is reduced to 10-15 minutes.						
Machinability	After curing, Wencon Rapid can be machined, drilled and worked like metal.						
Chemical Resistance	After curing, Wencon Rapid will be resistant to oil, water, salt water, most diluted acids and a range of solvents.						
Temperatur Resistance	<table border="0" style="width: 100%;"> <tr> <td style="padding-right: 20px;">Corrosion and heavy load:</td> <td>60°C (140°F)</td> </tr> <tr> <td>Light or no load:</td> <td>120°C (248°F)</td> </tr> <tr> <td>As filling compound:</td> <td>up to 250°C (482°F)</td> </tr> </table>	Corrosion and heavy load:	60°C (140°F)	Light or no load:	120°C (248°F)	As filling compound:	up to 250°C (482°F)
Corrosion and heavy load:	60°C (140°F)						
Light or no load:	120°C (248°F)						
As filling compound:	up to 250°C (482°F)						
Specific Volume	709 cm ³ /kg. (45,3 cu inch/kg)						
Hardness	Shore D 81.						
Handling Precautions	Read the instructions on the packaging and the Safety Data Sheet.						

Wencon Coating

General Description	<p>Wencon Coating is a two-component liquid coating. After curing, Wencon Coating will provide a smooth non-porous coating, which is resistant to bi-metallic corrosion, light chemical attack, corrosion and impingement. Wencon Coating contains no solvents.</p> <p>Typical applications are coating of surfaces rebuild after deterioration. Wencon Coating is used for coating of new or protection of pumps, valves, wet liners, cooler end covers or other surfaces, against corrosion and bi-metallic corrosion.</p>						
Surface Preparation	<p>Before applying, the surface must be clean. If possible shot blasted to Swedish Standard SA 2 1/2. Where impregnation of oil or salt is possible, the item is either left for 10-20 hours or heated to 30-40°C (86-104°F) in order to sweat out the oil or salt. Then the sandblasting is repeated. In some applications sandblasting is not possible and thorough grinding must take place to clean metal. N.B. Steelbrushing is not advisable as it gives a smooth surface. After grinding Wencon Bio Cleaner is used for degreasing.</p>						
Mixing Ratio	Mixing ratio 1:2 by volume. Mix the contents of the two tubs until an even colour is reached.						
Pot Life	20-30 minutes at 20°C (68°F), depending on amount.						
Applying	Wencon Coating is applied using the spatula supplied with the kit or a brush with half the length of the bristles cut away.						
Overcoating	Wencon Coating is applied in two operations. It is therefore supplied in two different colours, white and blue. The overcoating time depends on the temperature. The second coat must be applied whilst the first coat is still tacky. The time will vary from one to two hours. If full curing has occurred a light grit blasting is necessary prior to the second coat.						
Curing	Curing will take place in 10-15 hours. If the coating shall be exposed to chemicals, let it cure for 7 days before the exposure.						
Machinability	After curing, Wencon Coating can be machined, drilled and worked like metal.						
Chemical Resistance	After curing, Wencon Coating will be resistant to oil, water, salt water, most diluted acids and a range of solvents.						
Temperatur Resistance	<table border="0"> <tr> <td>Corrosion and heavy load:</td> <td>60°C (140°F)</td> </tr> <tr> <td>Light or no load:</td> <td>120°C (248°F)</td> </tr> <tr> <td>As filling compound:</td> <td>up to 250°C (482°F)</td> </tr> </table>	Corrosion and heavy load:	60°C (140°F)	Light or no load:	120°C (248°F)	As filling compound:	up to 250°C (482°F)
Corrosion and heavy load:	60°C (140°F)						
Light or no load:	120°C (248°F)						
As filling compound:	up to 250°C (482°F)						
Specific Volume	730 cm ³ /kg. (46,7 cu inch/kg)						
Coverage	1 kg/m ² (0,2 lb/sq. ft.) in 600 micron.						
Hardness	Shore D 80.						
Handling Precautions	Read the instructions on the packaging and the Safety Data Sheet.						

Wencon Hi-Temp

General Description	<p>Wencon Hi-Temp is a two-component liquid coating. After curing Wencon Hi-Temp will provide a smooth non porous coating, resistant to bi-metallic corrosion, medium chemical exposure, corrosion and erosion and impingement. Wencon Hi-Temp contains no solvents.</p> <p>Wencon Hi-Temp is ideal for protection of tanks, pumps and valves against chemical and mechanical aggression, corrosion and bi-metallic corrosion. Typical applications are coating of surfaces rebuild with Wencon Cream, including repair of lining on inert gas systems, fresh water generators, hot pipes and heating coils.</p>
Surface Preparation	<p>Before applying the surface must be clean. If possible shot blasted to Swedish Standard SA 21/2. Where impregnation of oil or salt is possible the part is either left for 10-20 hours or heated to 30-40°C (86-104°F) in order to sweat out oil or salt. Then shot blasting is repeated. In some applications shot blasting is not possible and a thorough grinding must take place to clean metal. N.B. Steel brushing is not advisable as it gives a smooth surface. After grinding Wencon Bio Cleaner is used for degreasing.</p>
Mixing Ratio	<p>Mixing ratio 1:2 by volume. Mix the contents of the two tubs until an even colour is reached. At low temperatures, the base part is very stiff. Apply heat for better mixing (up to 25°C).</p>
Pot Life	<p>20-40 minutes at 20 °C (68°F).</p>
Applying	<p>Wencon Hi-Temp is applied using either the spatula supplied with the kit or a brush, with half the length of the bristles cut away.</p>
Overcoating	<p>Wencon Hi-Temp is applied in two operations. It is therefore supplied in two different colours. The overcoating time depends on the temperature. The second coat must be applied whilst the first coat is still tacky. The time will vary from one to three hours. If full curing has occurred a light shot blasting is necessary prior to the second coat.</p>
Curing	<p>Curing will take place in 10 - 24 hours at 20 °C (68°F). If high chemical resistance is required, the item should cure for up to 7 days. Elevated temperatures will shorten the curing time.</p>
Machinability	<p>After curing, Wencon Hi-Temp forms a hard, durable material that is machinable with standard tools.</p>
Chemical Resistance	<p>After curing, Wencon Hi-Temp will be resistant to oil, water, salt water, most diluted acids and a number of solvents. It is advised to test the product for suitability.</p>
Temperature Resistance	<p>Corrosion and heavy load: 160°C (320°F) Light or no load: 220°C (430°F) As filling compound: up to 300°C (570°F)</p>
Specific Volume	<p>680 cm³/kg. (43,5 cu inch/kg)</p>
Hardness	<p>Shore D 82.</p>
Coverage	<p>Approx. 0,86 kg per m² at 600 micron layer.</p>
Handling Precautions	<p>Read the instructions on the packaging and the Safety Data Sheet.</p>

Wencon Putty

General Description	<p>Wencon Putty is a two-component mould able repair stick. Wencon Putty is supplied in 125g sticks / units, containing base and hardener.</p> <p>This multi purpose epoxy paste is ideal for wide range of emergency repairs where an ultra quick curing and mould able compound is required. Typical applications are patching sealing, filling of cracks, leakages and holes in pipes, flanges, tanks etc.</p>								
Surface Preparation	<p>Use grinder, emery cloth, etc. to achieve a clean, dry metal surface and degrease using Wencon Bio Cleaner.</p> <p>When repairing leaking pipes, it is possible to apply Wencon Putty direct into the leak and retain with a clip. This allows the area surrounding the leak to be ground and cleaned. Wencon Cream or Rapid is then applied with Wencon Reinforcement Tape to encapsulate the Wencon Putty and the clip.</p>								
Mixing Ratio	<p>Tear or cut equal amounts of base and hardener and knead in your hands until even colour develops. Each unit contains both base and hardener. Apply to clean and dry surface.</p>								
Pot Life	<p>3-6 minutes at 20°C (68°F)</p>								
Applying	<p>After mixing, place the Wencon Putty on to the prepared surface and massage it into the surface using the fingers. Heat cold items for better flow and adhesion.</p>								
Curing	<p>Curing time depends on the temperature and the thickness applied. If faster curing is required, heat can be added.</p> <table border="0"> <tr> <td>At 20°C (68°F):</td> <td>6 min.</td> </tr> <tr> <td>Initial Set:</td> <td>15 min.</td> </tr> <tr> <td>Machining:</td> <td>30 min.</td> </tr> <tr> <td>Full Mechanical:</td> <td>2 hours</td> </tr> </table>	At 20°C (68°F):	6 min.	Initial Set:	15 min.	Machining:	30 min.	Full Mechanical:	2 hours
At 20°C (68°F):	6 min.								
Initial Set:	15 min.								
Machining:	30 min.								
Full Mechanical:	2 hours								
Machinability	<p>After curing, Wencon Putty can be machined, drilled and worked like metal.</p>								
Chemical Resistance	<p>After curing, Wencon Putty will be resistant to oil, water, salt water, most diluted acids and a range of solvents.</p>								
Temperatur Resistance	<table border="0"> <tr> <td>Corrosion and heavy load:</td> <td>60°C (140°F)</td> </tr> <tr> <td>Light or no load:</td> <td>120°C (248°F)</td> </tr> <tr> <td>As filling compound:</td> <td>up to 250°C (482°F)</td> </tr> </table>	Corrosion and heavy load:	60°C (140°F)	Light or no load:	120°C (248°F)	As filling compound:	up to 250°C (482°F)		
Corrosion and heavy load:	60°C (140°F)								
Light or no load:	120°C (248°F)								
As filling compound:	up to 250°C (482°F)								
Specific Volume	<p>500 cm³/kg. (30 cu inch./kg)</p>								
Hardness	<p>Shore D 85.</p>								
Handling Precautions	<p>Read the instructions on the packaging and the Safety Data Sheet.</p>								

Wencon Pipe Tape

General Description	Wencon Pipe Tape is a fast curing pipe repair wrap specifically created to make quick and effective repairs of cracks, leaks, fractures, and corrosion porosity in piping carrying water, oil and most gases and solvents. Wencon Pipe Tape has good pressure, temperature and chemical resistance.
Surface Preparation	Prepare the surface by cleaning and abrading the area surrounding the damage. Degreasing with Wencon Bio Cleaner can improve adhesion.
Mixing Ratio	No mixing is required
Applying	Wencon Pipe Tape is pre-impregnated with polyurethane resin and is water activated.



1. Scan the QR code to read about optimal surface preparation by dry blasting. If lower performance is accepted, surface preparation can be done by a rotating blaster following a degrease with Wencon Cleaner
2. Tear off the needed amount* of putty and knead it in your hands until even colour
3. Place putty on the dry and clean surface and massage it into the damage using fingers
4. Soak pipe tape under water for 10 sec.
5. Wrap pipe tape firmly around pipe (min. 9 wraps with 50% overlap)
6. Dip gloves in water and smoothen pipe tape with hands in the direction of wrap until it sets
7. The pipe tape hardens after 10 min. and is fully cured after 60 min. (at 20 °C)

Pot Life	3-6 minutes depending on air and water temperature.
Curing time	The bandage hardens in 10 minutes and is fully cured within 1 hour at 20°C (68°F)
Machinability	No post curing machining necessary

Wencon Pipe Tape

Technical Data	Pipe pressure with Wencon Putty: 50 Bar Laboratory tests have shown much higher values, but the mentioned values will count for repairs done in situ. Users are advised to make their own tests if in doubt.
	Flexural strength: ASTM D709 111 N/mmsq. Tensile strength: ASTM D638 172 N/mmsq. Compression strength: ASTM D695 180 N/mmsq. Adhesion at one-inch single overlap: 19 N/mmsq. Dielectric strength: 16 KV/mm
Temperature Resistance	Continuous: 120°C (248°F) Peak: 190°C (374°F)
Chemical Resistance	Water, salt water, oil, diluted acids and alkalis.
Handling Precautions	Read the instructions on the packaging and the Safety Data Sheet

Wencon Exhaust Repair Kit

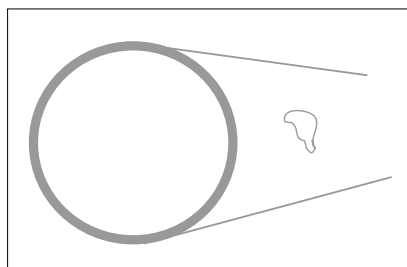

Cracks or leaks in exhaust systems etc. can only be repaired by using a product with a very high temperature resistance.

Wencon Exhaust System Repair Compound is a one-component product, with a temperature resistance up to 1000°C (1832°F) after full curing. To use the product, follow the simple guidelines below:

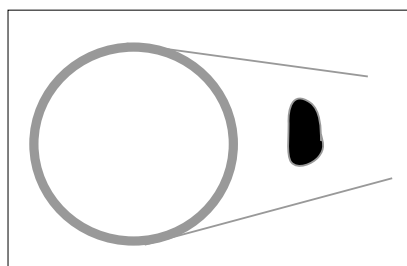

1. Grind and clean/degrease the affected area and the surrounding area. Use Wencon Bio Cleaner.
2. Open cartridge containing the product (Note: this is a one component product). Use a caulking gun to apply the product with. Apply a suitable amount in and around the leak.

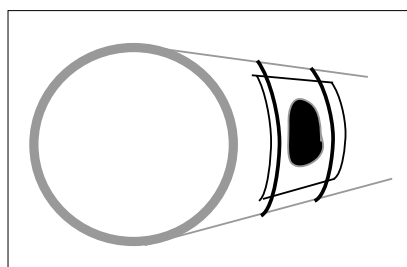

3. Cut a suitable piece of the metal mesh and fix it to the repair area using steel band or steel wires.
4. Apply second layer of the compound. Make sure the compound has completely solidified before exposing it to heat, otherwise the curing will not succeed.

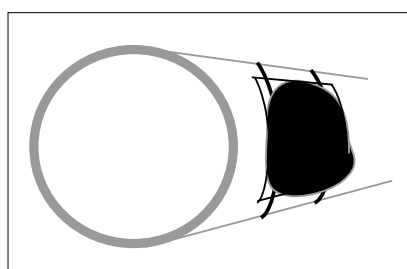

Remarks

It is important to note, that this product is designed for emergency repairs of leaks. It is not designed as for instance an internal lining for turbo charger housings.

Read the instructions on the packing and the Safety Data Sheet.

Wencon UW Putty for wet surfaces or under water

General Description	<p>Wencon UW Putty is a two-component compound, to be applied on wet surfaces or under water. After curing, Wencon UW Putty will exhibit a wide range of the characteristics of metals, which together with outstanding adhesion to all metallic surfaces, makes the Putty highly suitable for repair of corroded and worn metal. Wencon Putty is non conducting and will therefore not cause bi-metallic corrosion.</p> <p>Typical applications are corroded hulls and all under water parts of ships and structures, and to stop leaking tanks and pipes etc. Wencon Putty is also excellent for filling gaps and holes under water before completion with UW Cream / UW Coating.</p>						
Surface Preparation	<p>Before applying, the surface must be clean from loose paint, scales, under water growth, etc. A mechanical cleaning will do, but even better, if possible, hydrojetting.</p>						
Mixing Ratio	<p>Mixing ratio 1:1 by volume. Mix well until an even color is obtained. The mixing must take place above water. After mixing, the product can be taken into the water.</p>						
Pot Life	<p>Approximately 25min. at 20°C (68°F), depending on the amount mixed and the temperature.</p>						
Applying	<p>Wencon UW Putty is applied using your hands or a spatula supplied with the kit. Work the product well into the surface of the area to be treated, in order to obtain a close contact.</p>						
Curing	<p>Curing will take place in 10-18 hours, in the right temperature. Curing requires a temperature of at least 10°C (50°F), but better at 17-23°C (62-73°F) or higher. If the product shall be exposed to chemicals, let it cure for 7 days before the exposure.</p>						
Chemical Resistance	<p>After curing, the Wencon UW Putty will be resistant to oil, water, saltwater, most diluted acids and a range of solvents.</p>						
Temperature Resistance	<table border="0"> <tr> <td>Corrosion and heavy load:</td> <td>60°C (140°F)</td> </tr> <tr> <td>Light or no load:</td> <td>95°C (199°F)</td> </tr> <tr> <td>As filling compound:</td> <td>up to 95°C (199°F)</td> </tr> </table>	Corrosion and heavy load:	60°C (140°F)	Light or no load:	95°C (199°F)	As filling compound:	up to 95°C (199°F)
Corrosion and heavy load:	60°C (140°F)						
Light or no load:	95°C (199°F)						
As filling compound:	up to 95°C (199°F)						
Specific Volume	<p>556 cm³/kg.</p>						
Handling Precautions	<p>Read the instructions on the packaging and the Safety Data Sheet.</p>						
Remarks	<p>If thick layers shall be applied, the consistency may allow you only to apply part of the required thickness in one application (especially if the temperature is high). The overcoating time depends on the temperature and thickness. Next layer shall be applied while first layer is still tacky.</p>						

Wencon UW Cream for wet surfaces or under water

General Description	<p>Wencon UW Cream is a two-component compound, to be applied on wet surfaces or under water. After curing, Wencon UW Cream will exhibit a wide range of the characteristics of metals, which together with outstanding adhesion to all metallic surfaces, makes the compound highly suitable for repair of corroded and worn metal. Wencon Cream is non conducting and will therefore not cause bi-metallic corrosion.</p> <p>Typical applications are corroded hulls and all under water parts of ships and structures, tanks, pipes, flange faces. It is also excellent for filling up cavitation damages on hulls and rudders.</p>						
Surface Preparation	<p>Before applying, the surface must be clean from loose paint, scales, under water growth, etc. A mechanical cleaning will do, but even better, if possible, hydro-jetting.</p>						
Mixing Ratio	<p>Mixing ratio 1:2 by volume. Mix well until an even color is obtained. The mixing must take place above water. After mixing, the product can be taken into the water.</p>						
Pot Life	<p>25 - 35 min. at 20°C (68°F), depending on the amount mixed and temperature.</p>						
Applying	<p>Wencon UW Cream is applied using the spatula supplied with the kit. Work the product well into the surface of the area to be treated, in order to obtain a close contact. As an option, you can fill the product into an empty cartridge, and inject it from this. This often helps you keep the working place more clean and thereby prevent contamination of the water.</p>						
Curing	<p>Curing will take place in 10-18 hours, in the right temperature. Curing requires a temperature of at least 10°C (50°F), but better at 17-23°C (62-73°F) or higher. If the product shall be exposed to chemicals, let it cure for 7 days before the exposure.</p>						
Chemical Resistance	<p>After curing, the Wencon UW Cream will be resistant to oil, water, salt water, most diluted acids and a range of solvents.</p>						
Temperature Resistance	<table border="0"> <tr> <td>Corrosion and heavy load:</td> <td>60°C (140°F)</td> </tr> <tr> <td>Light or no load:</td> <td>100°C (212°F)</td> </tr> <tr> <td>As filling compound:</td> <td>up to 160°C (320°F)</td> </tr> </table>	Corrosion and heavy load:	60°C (140°F)	Light or no load:	100°C (212°F)	As filling compound:	up to 160°C (320°F)
Corrosion and heavy load:	60°C (140°F)						
Light or no load:	100°C (212°F)						
As filling compound:	up to 160°C (320°F)						
Specific Volume	<p>526 cm³/kg. (33,6 cu inch./kg)</p>						
Handling Precautions	<p>Read the instructions on the packaging and the Safety Data Sheet.</p>						
Remarks	<p>If thick layers shall be applied, the consistency may allow you only to apply part of the required thickness in one application (especially if the temperature is high). The overcoating time depends on the temperature and thickness. Next layer shall be applied while first layer is still tacky.</p>						

Wencon UW Coating for wet surfaces or under water

General Description	<p>Wencon UW Coating is a two-component liquid coating, to be applied on wet surfaces or under water. After curing, Wencon UW Coating will provide a smooth non-porous coating, which is resistant to bi-metallic corrosion, light chemical attack, corrosion and impingement. Wencon UW Coating contains no solvents.</p> <p>Typical applications are coatings of steel surfaces rebuild with Wencon UW Cream, and coatings under water - like ships hulls and/or other submerged structures, tanks, pipes etc. Examples of repairs under extreme conditions could be: on-site repair of sea-water filter housings etc. unable to achieve a dry surface. The UW Coating is used for scratched painting on hulls in splash-zones and under water.</p>
Surface Preparation	<p>Before applying, the surface must be clean from loose paint, scales, under water growth, etc. A mechanical cleaning will do, but even better, if possible, hydro-jetting.</p>
Mixing Ratio	<p>Mixing ratio 1:2 by volume. Mix well until an even color is obtained. The mixing must take place above water. After mixing, the product can be taken into the water.</p>
Pot Life	<p>25-35 minutes at 20°C (68°F), depending on amount.</p>
Applying	<p>Wencon UW Coating is applied using either a brush or a roller. If temperature is low, use brushes with short bristles, if temperature is high, use long bristles. The initial wetting of the brush and/or roller shall take place above water. Hereafter you can bring both the mixed product and the brush/roller into the water. Apply in a thickness of totally 300-350µ. Depending on temperature this thickness can be achieved in 2-3 layers.</p>
Overcoating	<p>Wencon UW Coating is applied in 2 operations, and is supplied in two different colours, orange and brown. The overcoating time depends on the temperature. The second coat must be applied while the first coat is still tacky. The time will vary from two to six hours.</p>
Curing	<p>Curing will take place in 10-18 hours, but only if temperature allows it to cure. Curing requires a temperature of at least 10°C (50°F), but better at 17-23°C (62-73°F) or higher. If the coating shall be exposed to chemicals, let it cure for 7 days before the exposure.</p>
Chemical Resistance	<p>After curing, the Wencon UW Coating will be resistant to oil, water, salt water, most diluted acids and a range of solvents.</p>
Temperature Resistance	<p>Corrosion and heavy load: 60°C (140°F) Light or no load: 100°C (212°F) As filling compound: up to 160°C (320°F)</p>
Specific Volume	<p>535 cm³/kg. (34,2cu inch./kg)</p>
Coverage:	<p>approx. 0,8 msq. per kg per coat.</p>
Handling Precautions	<p>Read the instructions on the packaging and the Safety Data Sheet.</p>
Remarks	<p>If thick layers shall be applied, the consistency may allow you only to apply part of the required thickness in one application (especially if the temperature is high). The overcoating time depends on the temperature and thickness. Next layer shall be applied, while first layer is still tacky.</p>

Wencon UW Coating (Low Viscosity)

General Description	<p>The Wencon UW Coating LV is essentially the identical product to Wencon UW Coating. Thanks to its low viscosity it is presented in cartridges which provides the following advantages:</p> <ul style="list-style-type: none"> - Spray application - Injection - Direct Hose/Brush application - Smooth automatic mixing
Surface Preparation	<p>Optimal: We recommend that the surface preparation prior to the application complies with ISO 8501 or a comparable quality certification to ensure the desired level of quality is achieved.</p> <p>Minimum: Before applying, the surface must be clean from loose paint, scales, underwater growth, etc. Mechanical cleaning is sufficient, but hydro-jetting is preferred where possible.</p>
Mixing Ratio	Mix by volume 2:1. The product will be mixed by the static mixer when it is dispensed from the cartridges
Pot Life	25-35 minutes at 20°C (68°F), depending on the quantity. When preheated to 35°C (95°F), Wencon UW LV pot life will be 3 to 5 minutes
Applying	<p>To obtain a smooth application process, we recommend preheating the cartridges to 35°C-40 °C (95°F-104°F) when using the spray and hose/brushes.</p> <p>Wencon UW Coating LV can be applied using traditional spatula, brush or roller.</p> <p>Wencon UW Coating LV filled in Sulzers MIXPAC™ & MixCoat™ Systems serves multiple purposes. When using a pneumatic dispenser and accessories, Wencon UW Coating LV can be:</p> <ul style="list-style-type: none"> - Sprayed - Injected - Brushed directly from cartridges
Overcoating	If a double layer is required, the overcoating time can vary from one to three hours, depending on the temperature. The second layer must be applied while the first layer is still tacky. The first layer will become tacky within 2 to 6 hours.
Compatibility	Wencon UW Coating LV is in general compatible with other epoxy-polyamide / amine paint & polyurethane coatings. These substrates bond well to each other as long as the surfaces are clean and slightly abraded.

Wencon UW Coating (Low Viscosity)

Curing	Curing will take place in 10 to 18 hours at 20°C (68°F) If the coating will be exposed to chemicals, allow it to cure for 7 days before exposure.
Chemical Resistance	After curing, Wencon UW Coating LV will be resistant to oil, water, saltwater, most diluted acids, and a range of solvents. Refer to the chemical resistance list.
Fire Resistance	Tested according to IMO Resolution MSC 307(88)(2010 FTP Code) Annex1: Part 2 and 5
Salt Spray Test	Tested according to ISO12944-9
Temperature Resistance	Corrosion and heavy load: Up to 60°C (140°F) Light or no load: Up to 100°C (212°F) As filling compound: Up to 160°C (320°F)
Specific Volume	524 cm ³ per kilogram (32,6 cubic inches/kg)
Coverage	Approximately 0.8 square meters per kg per coat. (8.6 Square foot)
Handling Precautions	Read the instructions on the packaging and the Safety Data Sheet.
Remarks	Cathodic protection systems must be isolated/disconnected, and the surface must be allowed to depolarize before underwater application.

Wencon Ceramic Cream

General Description	<p>Wencon Ceramic Cream is a two-component compound. After curing, Wencon Ceramic Cream will exhibit a wide range of the characteristics of metals, which together with outstanding adhesion to all metallic surfaces, makes the compound highly suitable for repair of corroded and worn metal. Wencon Ceramic Cream is non conducting and will therefore not cause bi-metallic corrosion.</p> <p>Wencon Ceramic Cream has a high abrasion resistance, making it suitable for applications on propeller nozzles, rudders, thruster tunnels and housings. In addition, the product also offer high temperature resistance, which makes it ideal for applications on gas scrubbers, condensers and end-covers.</p>						
Surface Preparation	<p>Before applying, the surface must be clean. If possible shot blasted to Swedish Standard SA 2 1/2. Where impregnation of oil or salt is possible, the item is either left for 10-20 hours or heated to 30-40°C (86-104°F) in order to sweat out the oil or salt. Then the shot blasting is repeated. In some applications sandblasting is not possible and thorough grinding must take place to clean metal.</p> <p>N.B. Steel brushing is not advisable as it gives a smooth surface. After grinding Wencon Bio Cleaner is used for degreasing.</p>						
Mixing Ratio	Mixing ratio 1:2 by volume. Mix until even colour is obtained.						
Pot Life	30-40 minutes at 20°C (68°F), depending on amount.						
Applying	Wencon Ceramic Cream is applied using the spatula supplied with the kit.						
Curing	Curing time depends on the temperature and the thickness applied. At 20°C (68°F) 10 -15 hours. If faster curing is required, heat can be added. At 100°C (212°F) curing time is reduced to 15-20 minutes.						
Chemical Resistance	After curing, Wencon Ceramic Cream will be resistant to oil, water, salt water, most diluted acids and a range of solvents.						
Temperature Resistance	<table border="0" style="width: 100%;"> <tr> <td style="padding-right: 20px;">Corrosion and heavy load:</td> <td>200°C (392°F)</td> </tr> <tr> <td>Light or no load:</td> <td>250°C (482°F)</td> </tr> <tr> <td>As filling compound</td> <td>up to 300°C (572°F)</td> </tr> </table>	Corrosion and heavy load:	200°C (392°F)	Light or no load:	250°C (482°F)	As filling compound	up to 300°C (572°F)
Corrosion and heavy load:	200°C (392°F)						
Light or no load:	250°C (482°F)						
As filling compound	up to 300°C (572°F)						
Specific Volume	538 cm ³ /kg (34,4 cu inch/kg)						
Hardness	Shore D 80.						
Handling Precautions	Read the instructions on the packaging and the Safety Data Sheet.						

Wencon Ceramic Coating

General Description	<p>Wencon Ceramic Coating is a two-component liquid coating. After curing, Wencon Ceramic Coating will provide a smooth non-porous coating, which is resistant to bi-metallic corrosion, light chemical attack, corrosion and impingement. Wencon Ceramic Coating contains no solvents.</p> <p>Wencon Ceramic Coating has a high abrasion resistance, making it suitable for coatings on propeller nozzles, rudders, thruster tunnels and housings. Typical applications are coating of surfaces rebuilt with Wencon Ceramic Cream and protection against wear, corrosion and bi-metallic corrosions. In addition, the product also offer high temperature resistance, which makes it ideal for applications on gas scrubbers, condensers and end-covers.</p>						
Surface Preparation	<p>Before applying, the surface must be clean. If possible shot blasted to Swedish Standard SA 2 1/2. Where impregnation of oil or salt is possible, the item is either left for 10-20 hours or heated to 30-40°C (86-104°F) in order to sweat out the oil or salt. Then the sandblasting is repeated. In some applications sandblasting is not possible and thorough grinding must take place to clean metal. N.B. Steel brushing is not advisable as it gives a smooth surface. After grinding, Wencon Bio Cleaner is used for degreasing.</p>						
Mixing Ratio	Mixing ratio 1:2 by volume. Mix until even color is obtained.						
Pot Life	20-30 minutes at 20°C (68°F), depending on amount.						
Applying	Wencon Ceramic Coating is applied using the spatula supplied with the kit or a brush with half the length of the bristles cut away.						
Overcoating	Wencon Ceramic Coating is applied in two operations. It is therefore supplied in two different colours, light grey and light green. The overcoating time depends on the temperature. The second coat must be applied while the first coat is still tacky. The time will vary from one to two hours. If full curing has occurred a light shot blasting is necessary prior to the second coat.						
Curing	Curing will take place in 10-15 hours. If the coating shall be exposed to chemicals, let it cure for 7 days before the exposure.						
Chemical Resistance	After curing, Wencon Ceramic Coating will be resistant to oil, water, salt water, most diluted acids and a range of solvents.						
Temperature Resistance	<table border="0"> <tr> <td>Corrosion and heavy load:</td> <td>220°C (428°F)</td> </tr> <tr> <td>Light or no load:</td> <td>260°C (500°F)</td> </tr> <tr> <td>As filling compound:</td> <td>up to 320°C (608°F)</td> </tr> </table>	Corrosion and heavy load:	220°C (428°F)	Light or no load:	260°C (500°F)	As filling compound:	up to 320°C (608°F)
Corrosion and heavy load:	220°C (428°F)						
Light or no load:	260°C (500°F)						
As filling compound:	up to 320°C (608°F)						
Specific Volume	658 cm ³ /kg. (42 cu inch/kg)						
Coverage	1 kg/m ² (0,2 lb/sq. ft.) in 600 micron.						
Hardness	Shore D 81.						
Handling Precautions	Read the instructions on the packaging and the Safety Data Sheet.						

Wencon Rotating Blaster

General Description	Wencon Rotating Blaster discs are rubber mounted tungsten tips used for surface preparation of steel surfaces, pipes, tanks and bends, marine decks and hulls that leaves a profile according to standards for hand and power tool surface preparation: ISO 8501, ST3 and SSPC-SP3.
Safety	Always wear goggles, working gloves, dust mask and protective clothing
Use	Hold the disc at 90 degrees to the surface and rotate clockwise Do not press too hard with the single and double discs Always work away from edges
Strip capacity	A single Wencon Rotating Blaster disc will strip 1 to 3m ² per hour The triple Wencon Rotating Blaster disc will strip around 30m ²
Rotating speed	Maximum speed 4000 rpm Optimal speed between 2500 and 3000 rvpm
Applying	When cleaning iron and steel, prime immediately
Tools	The Rotating blaster disks can be powered by a standard drilling machine.
Technical	Disk diameter: 126 mm +/- 0.8 mm Disk width: 6.7 mm +/- 0.3 mm (Per disc) Stud size: 8 mm Rubber: Natural stained rubber Hardness: 50 Shore A Carbide: Hardness 1500HV Tool mount: M12m
Handling Precautions	Read the instructions on the packaging and the Safety Data Sheet.

Wencon Cleaner

Wencon Cleaner

General Description

Wencon Cleaner is a tetrachloroethylene based degreasing agent, which is used for cleaning purposes prior to application of the Wencon products. After surface preparation, apply Wencon Cleaner with a brush and allow the product to evaporate before applying other Wencon products. Wencon Cleaner is non-flammable. Use only in large or well ventilated rooms.

Wencon Cleaner is supplied in 500ml units.

Wencon Bio Cleaner

General Description

Wencon Bio Cleaner is a water based alkaline degreaser, which is used for cleaning purposes prior to application of Wencon products. Wencon Bio Cleaner is an environmentally friendly product and is classified as Non Dangerous Goods.

Wencon Bio Cleaner is delivered with a separate spray, which is set for foam spray when delivered. We recommend using foam spray, due to the efficiency.

Wet surface: Apply Wencon Bio Cleaner and let it work for 5-10 min. If necessary use a brush, to make sure the surface is clean. Rinse off the Wencon Bio Cleaner with plenty of clean water, for proper degreasing and to ensure that all Cleaner residue is washed away. Apply Wencon UW Coating as a primer, and hereafter any Wencon products can be applied.

Dry surface: Apply Wencon Bio Cleaner and let it work for 5-10 min. If necessary use a brush, to make sure the surface is clean. Rinse off the Wencon Bio Cleaner with plenty of clean water, for proper degreasing and to ensure that all Cleaner residue is washed away. Allow the surface to evaporate until completely dry and hereafter any Wencon products can be applied.

Wencon Bio Cleaner is supplied in 750 ml units.

Wencon Reinforcement Tape

Wencon Reinforcement Tape

General Description

Wencon Reinforcement Tape is a fibre tape used for reinforcing the Wencon repair. e.g. pipe repairs and repairs of cracks or holes in engine blocks, oil sumps, etc. After mixing e.g. the Wencon Cream, cut off a length of reinforcement tape. Place it on the mixing board and apply a 2-5 mm thick layer of Wencon Cream on top, using the mixing knife.

Next wrap the impregnated Wencon Reinforcement Tape around the pipe having the Wencon Cream on the inner side. The length of the tape should enable it to go 3-4 times around the pipe.

Wencon Reinforcement Tape is supplied in following units:

Wencon Reinforcement Tape 0,05 x 10 m (400 inch)

Wencon Reinforcement Tape 0,10 x 20 m (800 inch)

Wencon Release Agent

Wencon Release Agent

General Description

Wencon Release Agent is used in applications where you want to prevent adhesion between Wencon and the substrate. The Release Agent is applied in a thin layer and left for drying in ten minutes. Remove excess material using a cloth.

Example:

When repairing an oversized roller bearing house by casting the Wencon compound around the bearing, the Wencon Release Agent is applied to the roller bearing itself.

When repairing a corroded flange face, it can be done by applying Wencon compound to one flange and Wencon Release Agent to the other. Before curing of Wencon compound, the two flanges are assembled. The use of Release Agent ensures the possibility for disassembly.

Wencon Release Agent is supplied in 50 g units.

Notes ...

Index - Chapter 3

Wencon physical properties - S.I metrics system	58
Formulas geometry	59
Rectangle	59
Triangle	59
Circle	59
Regular box.....	59
Formulas geometri	60
Ball with radius r	60
Rectangular cylinder	60
Cone	60
Truncated cone	60
How to calculate	61
Coating a surface.....	61
How to calculate	62
Example 2: Coating a tank	62
Wencon Test Methods.....	63
Test of resistance to liquid pressure	64
Force - Dantest Certificate.....	65
Chemical resistance list.....	67

Wencon physical properties - S.I metrics system

	Wencon Cream	Wencon Rapid	Wencon Coating white+blue	Wencon Hi-Temp yellow+green	Wencon Putty	Wencon Pipe Tape	Wencon Exhaust Repair kit	Wencon UW Cream	Wencon UW Coating orange+brown	Wencon UW Coating LV	Wencon UW Putty	Wencon Ceramic Cream	Wencon Ceramic Coating grey+green
Max. Temperature	+60 - +250°C	+60 - +250°C	+60 - +250°C	+160 - +300°C	+60 - +250°C	+120°C	Up to +1000°C (1832°F)	+60 - +160°C	+60 - +160°C	+60 - +160°C	+60 - +95°C	+200 - +300°C	+220 - +320°C
Consistency	paste	paste	fluid	fluid	putty		fluid	paste	fluid	fluid	putty	paste	fluid
Mixing ratio vol.	1:1	1:1	1:2	1:2	-	hand	No mixing. see prod. Info.	1:2	1:2	2:1	1:1	1:2	1:2
Apply with	spatula	spatula	spatula/brush	spatula/brush	hand/spatula			spatula	spatula/brush	Spray	hand/spatula	spatula	spatula/brush
Potlife at 20 C.	30-60 min. Mixed in small amounts	10-20 min. mixed in small amounts	20-30 min. mixed in small amounts	20-40 min. mixed in small amounts	3-6 min. mixed in small amounts	4-6 min.		25-30 min. mixed in small amounts	25-35 min. mixed in small amounts	15-20 min. in nozzle	25 minutes	30-40 min. mixed in small amounts	20-30 min. mixed in small amounts
Curing time	10 - 15 hrs	40 - 90 min.	10 - 15 hrs	10 - 24 hrs	10 - 20 min.	10 - 30 min.	Initial curing 3-4 hrs	10 - 18 hrs	10 - 18 hrs	10-18 hrs.	10 - 18 hrs	10 - 15 hrs	10 - 15 hrs
Machinability	yes	yes	yes	yes	yes		yes	yes	yes	yes	yes	yes	yes
Hardness shore D	75	81	80	82	85	N/A	N/A	79	79	80	76	80	81
Tensile strength Rcrack	14,30 N/mm ²	9,20 N/mm ²	12,90 N/mm ²	13,80 N/mm ²	4,60 N/mm ²	172 N/mm ²	N/A	35,80 N/mm ²	37,50 N/mm ²	37,00 N/mm ²	17,6 N/mm ²	25,80 N/mm ²	25,40 N/mm ²
Compressive strength Rcrack	58 N/mm ²	112 N/mm ²	95 N/mm ²	96 N/mm ²	35,14 N/mm ²	180 N/mm ²	N/A	134 N/mm ²	133 N/mm ²	130 N/mm ²	25,30 N/mm ²	65,10 N/mm ²	124 N/mm ²
Compr. strength modulus of elasticity	1.689 N/mm ²	2.891 N/mm ²	2.199 N/mm ²	4.284 N/mm ²	NA		N/A	2.631 N/mm ²	3.117 N/mm ²	3.282 N/mm ²	3.400 N/mm ²	2.799 N/mm ²	3.030 N/mm ²
Shear adhesion *	14,40 N/mm ²	20 N/mm ²	16,20 N/mm ²	22,40 N/mm ²	4,50 N/mm ²	19 N/mm ²	N/A	33 N/mm ²	31,90 N/mm ²	31,1 N/mm ²	15,90 N/mm ²	30,80 N/mm ²	28,90 N/mm ²
Adhesion to steel **	>3.0 N/mm ²	2,0 N/mm ²	6,0 N/mm ²	3,4 N/mm ²	>4,5 N/mm ²		N/A	>7,5 N/mm ²	>7,5 N/mm ²	>7,5 N/mm ²	>6,5 N/mm ²	6,7 N/mm ²	4,5 N/mm ²
Specific volume	775 cm ³ / kg	709 cm ³ / kg	730 cm ³ / kg	680 cm ³ / kg	500 cm ³ / kg		735 cm ³ / kg	526 cm ³ / kg	535 cm ³ / kg	524 cm ³ / kg	556 cm ³ / kg	538 cm ³ / kg	658 cm ³ / kg
Heat resistance													
Corrosion	60°C (140°F)	60°C (140°F)	60°C (140°F)	160°C (320°F)	60°C (140°F)	120°C (248°F) peak 190°C (374°F)		60°C (140°F)	60°C (140°F)	60°C (140°F)	60°C (140°F)	200°C (392°F)	220°C (428°F)
Light or no load	120°C (248°F)	120°C (248°F)	120°C (248°F)	220°C (430°F)	120°C (248°F)			100°C (212°F)	100°C (212°F)	100°C (212°F)	95°C (199°F)	250°C (482°F)	260°C (500°F)
For filling only	250°C (482°F)	250°C (482°F)	250°C (482°F)	300°C (570°F)	250°C (482°F)			160°C (320°F)	160°C (320°F)	160°C (320°F)	95°C (199°F)	300°C (572°F)	320°C (608°F)
Dielectric strength	10 KV/mm	10 KV/mm	10 KV/mm	10 KV/mm	N/A	N/A		10 KV/mm	10 KV/mm		N/A	N/A	10 KV/mm
Hardness	Shore D, DIN 53505												
Tensile strength	N/mm ² (10kg/cm ²) DIN 53454												
Compressive strength	N/mm ² DIN 53454												
Shear adhesion *	Single-lap-joint acc. to ASTM D1002												
Adhesion to steel **	N/mm ² (10kg/cm ²) / ISO 4624												
Specific volume	cm ³ per kilogram												

Formulas geometry

Rectangle

Area:

$$A = a \times b$$

Round:

$$R = 2 \times a + 2 \times b$$



Triangle

Round:

$$R = a + b + c$$

Area:

$$\text{Area} = \frac{1}{2} \times h \times b$$

$$\text{Area} = \frac{1}{2} a \times b \times \sin A$$

$$\text{Area} = \sqrt{s(s-a)(s-b)(s-c)}$$

$$s = \frac{1}{2}(a + b + c)$$

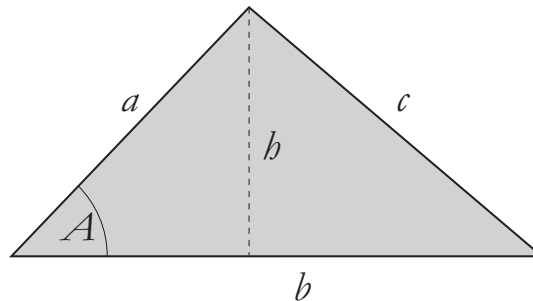

Circle

Area:

$$A = \pi \times r^2$$

Round:

$$R = 2 \times \pi \times r$$

$$\pi = 3,14$$

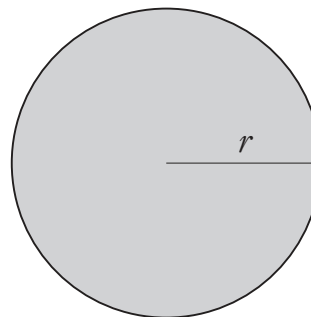

Regular box

Length a

Height b

Wide c

Volume:

$$V = a \times b \times c$$

Surface:

$$S = 2 \times (a \times b + a \times c + b \times c)$$

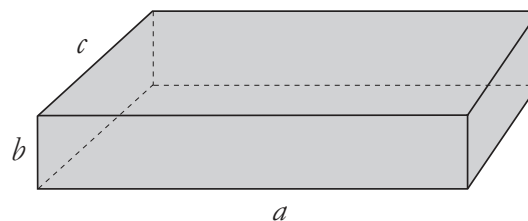

Formulas geometri

Ball with radius r

Volume:

$$V = \frac{4}{3} \times \pi \times r^3$$

Surface:

$$S = 4 \times \pi \times r^2$$

$$\pi = 3,14$$

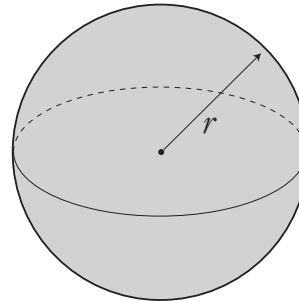

Rectangular cylinder

with radius r & height h

$$\pi = 3,14$$

Volume:

$$V = \pi \times r^2 \times h$$

Bending surface:

$$S = 2 \times \pi \times r \times h$$

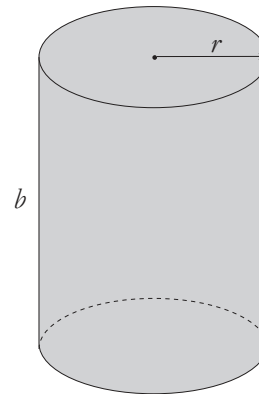

Cone

Volume:

$$V = \frac{1}{3} \times \pi \times r^2 \times h$$

Bending surface:

$$S = \pi \times r \times \sqrt{r^2 + h^2} = \pi \times r \times a$$

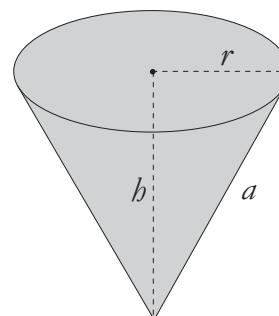

Truncated cone

Volume:

$$V = \frac{1}{3} \times \pi \times h \times (a^2 + a \times b + b^2)$$

Bending surface:

$$S = \pi \times (a+b) \times \sqrt{h^2 + (b-a)^2} = \pi \times (a + b) \times c$$

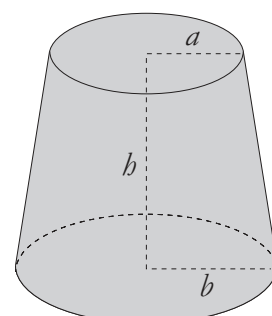

How to calculate

Coating a surface

Coating can be done on a flat surface, or a bended surface (pipe, round tank etc.).

Layer thickness has to be decided, prior to coating a surface. For a coating, Wencon recommends 600-800 microns (0.6 - 0.8 mm). To calculate the consumption of Wencon Coating, use the examples shown below.

Example 1: Coating a flat surface

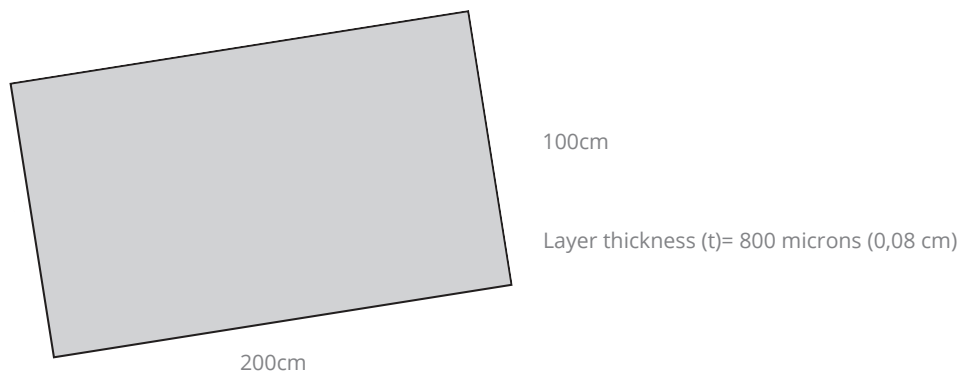

Volume of coating = 200 cm x 100 cm x 0,08 cm = 1600 cm³

Specific volume of Wencon Coating Blue or Wencon White

1 kg = 745 cm³

$$\frac{1600 \text{ cm}^3}{745 \text{ cm}^3} = 2,15 \text{ kg}$$

Theoretical value is 2.15 kg. There is a calculated waist (mixing, potlife, variation in layer thickness etc.) In practice you have to multiply with a waistfactor varying from 1.2 to 2 according to your own experience.

In our documentation we calculate with a waste of 25 % This means that when the theoretical coverage in 600 micron is 0,8 kg/m², the practical coverage will be 0,8kg/m² + 25% = 1 kg/ m².

How to calculate

Example 2: Coating a tank

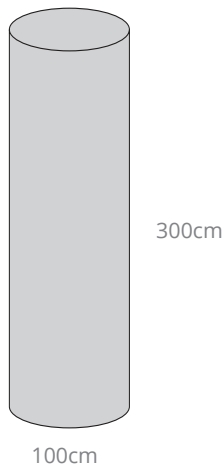

Layer thickness (t) 800 microns (0,08 cm)

Cylinder part:

$$2 \times \pi \times r \times h \times t = 2 \times 3,14 \times 50 \times 300 \times 0,08 = 7536 \text{ cm}^3$$

Top and bottom plates:

$$\pi \times r^2 \times 2 \times t = 3,14 \times 50^2 \times 2 \times 0,08 = 1256 \text{ cm}^3$$

Total coating volume is $7536 \text{ cm}^3 + 1256 \text{ cm}^3 = 8792 \text{ cm}^3$

Specific volume for Wencon Coating 1 kg = 745 cm^3

$$\text{Consumption} = \frac{8792 \text{ cm}^3}{745 \text{ cm}^3} = 11,8 \text{ kg (theoretical)}$$

In practice $11,8 \text{ kg} \times 1,25$ (or other weight factor - see x 1) = $14,75 \text{ kg}$

Example 3: Coating a pipe outside - examples calculated per m pipe

Below is a table showing the theoretical consumption of Wencon Reinforcement Tape and Wencon blue / white coating at different pipe diameters, applying 3 rounds or 5 rounds of Reinforcement Tape. All values calculated per m pipe.

The same table can be used for Wencon Hi Temp Coating and Wencon UW Coating by adding 8 % to the consumption of blue/white coating.

Important: The shown values are theoretical, and you have to multiply with a waste factor (1,2 - 2 according to your own experience) to reach the practical consumption.

Pipe diameter	3 Rounds	5 Rounds
1 mtr x 20 mm	0,13 kg - 8 m	0,22 kg - 13 m
1 mtr x 30 mm	0,20 kg - 12 m	0,32 kg - 19 m
1 mtr x 50 mm	0,32 kg - 19 m	0,53 kg - 32 m
1 mtr x 60 mm	0,38 kg - 23 m	0,64 kg - 38 m
1 mtr x 70 mm	0,45 kg - 27 m	0,74 kg - 44 m
1 mtr x 80 mm	0,51 kg - 31 m	0,85 kg - 51 m
1 mtr x 90 mm	0,57 kg - 34 m	0,95 kg - 57 m
1 mtr x 100 mm	0,64 kg - 38 m	1,10 kg - 63 m
1 mtr x 120 mm	0,76 kg - 46 m	1,30 kg - 76 m
1 mtr x 160 mm	1,02 kg - 61 m	1,70 kg - 101 m
1 mtr x 200 mm	1,30 kg - 76 m	2,10 kg - 126 m
1 mtr x 250 mm	1,60 kg - 95 m	2,70 kg - 157 m
1 mtr x 300 mm	2,00 kg - 113 m	3,20 kg - 189 m

Wencon Test Methods

All Wencon Epoxy products are tested according to below mentioned methods. Only the test, important for calculation of which product to choose for which application, are mentioned below:

1. All tests are with the exception of the determination of the heat resistance, executed at room temperature 20°C (68°F).
2. The pot life and "highest temperature during reaction" are determined with 100 grams mixed material. The rise of temperature is measured with the aid of a digital thermometer.
3. For the determination of the heat resistance, the products are coated on steel plates and stored during seven days at room temperature. After those seven days they are stored at elevated temperature and reviewed every 24 hours.
4. Compressive strength:
 - Curing time: 14 days
 - Dimensions of the cubes: 13 x 13 x 13 mm
 - Used testing machine: Wolpert, type TT 1220 25 kN
 - Testing speed: 5 mm / min.

Modulus of elasticity: A calculated factor showing the relationship between the pressure on the material and the deformation.

R crack : The point where the material breaks apart

5. Tensile strength:
 - Curing time: 14 days
 - used testing machine: Wolpert, type TT 1220 25 kN
 - Testing speed: 15 mm / min.

Modulus of elasticity: A calculated factor showing the relationship between the pressure on the material and the deformation.

R crack : The point where the material breaks apart

6. Shear adhesion to steel: The shear adhesion is determined according to the subjoined illustration

The test bars are sandblasted to optimise the adhesion of the Wencon product. After the surfaces were glued together with the several Wencon products, they are cured seven days at room temperature.

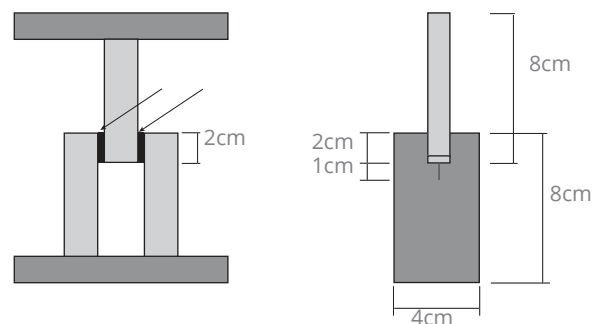

The shear adhesion is determined using the following testing machine: Wolpert, type TT 1220 25 kN. The shear adhesion is calculated according to following formula:

$$X = P / A$$

X: shear adhesion (N/mm²)

P: pressure at break (N)

A: total of the glued area (mm²)

Test of resistance to liquid pressure

Test of resistance to liquid pressure for Wencon

Product: WENCON RAPID

Test issued by: Flådestation Frederikshavn (The Danish Navy) being accredited test facility for pressure tests.

Objective: To establish a description for the product's ability for use in repairing holes and leaks in pressure vessels, pipes, etc.

Description: Two specimens were made, having holes as shown in ill.

1. $\varnothing 1 = 11,2$ mm, $\varnothing 2 = 50,0$ mm, A = 5 mm, B = 7 mm, reinforcement.: None.

2. $\varnothing 1 = 16,0$ mm, $\varnothing 2 = 50,0$ mm, A = 10,0 mm, B = 9 mm, reinforcement : 2 layers of fiber tape

The water pressure was given from the side, where $\varnothing 2$ is situated.

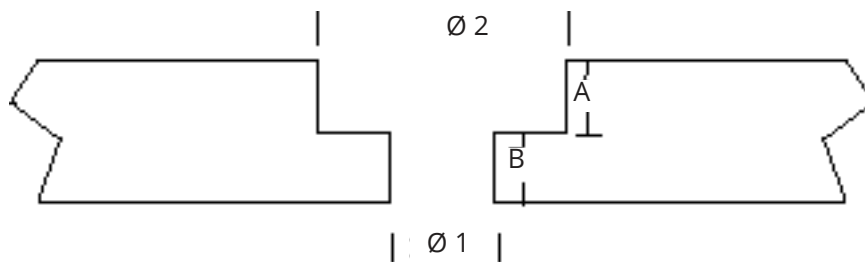

The test pieces were made and were left for curing in 48 hours. Hereafter they were subjected to water pressure.

1. Test piece No. 1 was mounted in the test stand, sealed with klingerit seal for 25 bar. The pressure was raised to 60 bar, at which pressure the seal was blown out. The test stand was renovated and O-ring seats were machined instead. The test was repeated. In the second test, the pressure was raised to 160 bar, at which pressure the flange was deformed to an extent, where the O-rings were blown out.

Conclusion:

At a pressure of 160 bar, there was no sign of damage to the repaired area of Test piece 1.

2. Test piece No. 2 was mounted in the test stand, and the pressure was raised to 425 bar, at which pressure the flange was deformed to an extent, where the O-rings were blown out.

Conclusion:

At a pressure of 425 bar, there was no sign of damage to the repaired area of Test piece 2.

16.05.95

DANAK Reg. No. 8

Test Report

FORCE-Dantest CERT

 Wencon ApS
 Jyllandsvej 15
 DK-5400 Bogense

 File No. 133224/m1493-681
 Date 2000-03-01
 Page 1 of 1
 Enclosure 0
 KG/BR

FORCE Institute hereby informs you about the result of the testing of 5 pieces of steel pipe delivered to us on 16th February 2000.

The pipes had an outside diameter of approx. 50 mm and a length of approx. 260 mm and they were numbered 2, 3, 5, 6 and 8 respectively.

The pipes were closed in both ends with a welded end plate - one solid and one with a threaded hole, and each pipe had a wrapped bandage with a total width of approx. 90 mm. According to statement the bandages were placed to cover bored holes with diameter 5 mm.

To each pipe an increasing internal water pressure was applied up to 240 bar at room temperature.

All the bandages leaked water at a pressure lower than 240 bar but after releasing the pressure of 240 bar no visible defects were observed on the bandages.

The pressures where the bandages showed leakage are stated in the table below.

Pipe No.	Leakage occurred at
2	155 bar
3	160 bar
5	175 bar
6	169 bar
8	158 bar

FORCE Institute
 Inspection and Testing



Kjeld Grønfeldt
 B.Sc. (Mech. Eng.)

Extracts from the Test Report may only be reproduced with a written permission from this Institute.
 The test results relate only to the items tested.

The "General Conditions" on the reverse page are an integral part of our services.

456.E. 02.97

Copenhagen
 Main Office
 Park Allé 345
 DK-2605 Brøndby
 Tel. + 45 43 26 70 00
 Fax + 45 43 26 70 11
 e-mail force@force.dk
 www.force.dk

Esbjerg
 Oestre Gjesingvej 7
 DK-6715 Esbjerg N
 Tel. + 45 76 10 06 50
 Fax + 45 75 45 00 86

Vejle
 Navervej 1
 DK-6600 Vejle
 Tel. + 45 76 96 16 00
 Fax + 45 75 36 41 55

Aalborg
 Niels Jernes Vej 2-4
 DK-9220 Aalborg Oe
 Tel. + 45 96 35 08 00
 Fax + 45 96 35 08 29

Aarhus
 Kongsvang Allé 43
 DK-8000 Aarhus C
 Tel. + 45 87 34 02 00
 Fax + 45 87 34 02 19

Helsingborg
 Branch
 Karbingatan 30
 S-254 67 Helsingborg
 Tel. + 46 42 15 21 40
 Fax + 46 42 16 13 20

STK Inter Test AB
 Subsidiary
 Tallmätargatan 7
 S-721 34 Västerås
 Tel. + 46 21 18 02 70
 Fax + 46 21 18 02 02

Affiliated with the Danish Academy of Technical Sciences

Declaration of Asbestos-Free Products

Manufacturer / Supplier

Company name:	Wencon ApS
Street:	Jyllandsvej 15
ZIP code:	5400
City:	Bogense
Country:	Denmark
Position:	
Phone:	+45 6481 1010

We declare in accordance with the SOLAS Regulation II-I/3-5, New Installation of Asbestos in connection with IMO MSC.1/Circ.1374 and 1379:

**All materials, products and components
for supply by our company are completely free of asbestos.**

On behalf of:	Wencon ApS (Company name)
Date:	November 17, 2025
Name of authorized representative:	Keld Willberg CEO, Wencon ApS

Chemical resistance list

Inorganic Acids	Arsenic acid	2
	Carbonic acid	2
	Hydrobromic acid (0-10%)	2
	Hydrochloric acid (0-10%)	2
	Hydrochloric acid (10-20%)	1
	Hydrochloric acid (above 20%)	0
	Nitric acid (0-10%)	2
	Nitric acid (10-20%)	1
	Nitric acid (above 20%)	0
	Nitrous acid (0-10%)	2
	Oleum	-
	Phosphoric acid (0-5%)	2
	Phosphoric acid (5-10%)	1
	Sulfuric acid (0-10%)	2
	Sulfuric acid (10-20%)	1
	Organic Acids	Acetic acid (0-10%)
Acetic acid (10-20%)		2
Acetic acid (above 20%)		0
Benzoic acid		2
Carbolic acid		0
Chloroacetic acid		0
Chlorosulphonic acid (dry)		0
Chlorosulphonic acid (wet)		0
Creosote oil		0
Cresylic acid		-
Fatty acid (high mol.w)		2
Formic acid (0-10%)		1
Formic acid (above 10%)		0
Lactic acid (0-10%)		1
Linoleic acid		2
Maleic acid		2
Malic acid		2
Oleic acid		2
Phenol (100%)		-
Phthalic acid		2
Phthalic anhydride		2

Chemical resistance list

Alcohols	The test for alcohols show good resistance. However, Wencon recommend to make a test for each application.	
Alkalis	Ammonia, anhydrous	2
	Ammonia, solution	2
	Barium hydroxide	2
	Calcium hydroxide	2
	Magnesium hydroxide	2
	Potassium hydroxide (0-20%)	2
	Potassium hydroxide (above 20%)	1
	Soap solutions (stearates)	2
	Sodium Hydroxide (0-20%)	2
	Sodium hydroxide (above 20%)	1
Oils	The system seems to be resistant to all types of oil, vegetable, animal and mineral types as well as hydrocarbons except for the halogenated ones.	
Key	Very good	2
	Good	1
	Fair	0
	Not good	-
Before entering large application jobs, it is recommended to test the product against the medium.		
THIS RESISTANCE LIST IS ONLY FOR INTERNAL USE AND IS NOT MEANT AS PART OF THE BROCHURES. LABORATORY TESTS DO NOT ALWAYS SHOW RELIABLE FIGURES. WENCON COMPANY TAKES NO RESPONSIBILITY FOR APPLICATIONS MADE.		

Index - Chapter 4

1 Blasting	70
1.1. Dry Blasting	70
1.2 Wet Blasting	71
2. Rotating Blasting	71
3. Grinding	71
4. Needle Gunning	71
5. Machining	71
6. Steam cleaning	72
7. Dehumidification	72
8. Steel brushing	72

1 Blasting

There are basically two different methods of blasting. Wet blasting and dry blasting. Shot-blasting, sand-blasting and grit-blasting employ different types of blasting material, but are essentially the same. In this manual we will use the word blasting.

1.1. Dry Blasting

Dry blasting is the most common kind of blasting. Blasting is not only used for cleaning metal surfaces, but is also used widely for cleaning before painting houses, steel constructions etc. Blasting offers the best physical adherence, prior to application with Wencon products and is the most efficient way of cleaning the parts. We recommend to use blasting prior to an application. If blasting is impossible, other ways of surface preparation must be adopted. Machine parts that have been in use, for instance in sea water, will have quite an amount of water and salt penetration into the metal structure. This penetration should be removed before application, meaning; sufficient salt and water should be removed, to ensure salt and water do not enter the surface of the substrate, before Wencon compound has cured. If the surface of a machine part shortly after blasting, turns black or very dark, it may be a sign of salts sweating from the substrate. A way of accelerating the sweating out of the salts, is by heating up the part or leaving it in a warm place for at least 12 hours. The most efficient way of removing water from the substrate is by using dehumidification units. (See Wet Blasting) In most cases it may be a good idea to use written specifications.

Specification for Dry Blasting

1. Blast the machine part to SA 2 ½ using sharp-edged blasting media, to a roughness of min. Rz 75 microns.
2. Leave the part for sweating out salts in a warm place for at least 12 hours or heat it up to 30 - 40 °C (86-104 °F) using gas torches.
3. Blast again to SA 2 ½ immediately prior to the application.
4. For parts containing lots of water and salt it may be necessary to repeat 2. and 3. until the surface remains light grey for at least 2 hours after blasting. Most companies will understand a specification like this, it may be necessary to check the blasting prior to application. If there are any signs of salts sweating out, the parts must be blasted again.

- 1.2 Wet Blasting**
- Some applications do not allow dry blasting, due to dust coming from the process. For instance on site, with motors, pumps, valves etc. in close proximity. The reason being that dust will enter roller bearings, etc. even inside the motors. In such conditions, the solution might be wet blasting. Wet blasting is carried out in almost the same manner as dry, but using water in union with air and grit. We use the same standards as for the dry blasting (SA 2.5, SA 3 etc.). There are two challenges that might follow wet blasting. The first being that the technique leaves the substrate wet, the other being the fact that a wet surface will oxidise before getting dry.
- Dehumidification. Prior to application on a surface that has been wet blasted, a dehumidification must take place. Dehumidification units can be hired from a relevant supplier. Make sure you are instructed, to choose the correct type and size for the application. After dehumidification a light dry blasting may be necessary. It may be done using equipment, that retrieves the blasting material and dust by means of vacuum suction.
- 2. Rotating Blasting**
- Using a Rotating Blaster is like blasting, but without sand. Rotating Blaster is a rubber disc with hard steel spikes mounted on the periphery. Rotating Blaster can be mounted in a normal drilling machine, and the result is a surface close to a blasted surface - clean and rough with sharp edges. Rotating Blaster discs can be ordered at Wencon and at all Wencon distributors.
- 3. Grinding**
- Grinding is for small repair jobs, with too many objections for blasting. Wheel grinding may be an solution, in cases where it is possible to grind the entire surface, mostly when repairing mechanical damages. Corroded areas are often in a state where a wheel grinder will only be able to cover part of the surface, and is therefore not advisable. When grinding use a coarse stone. Use Wencon Bio Cleaner before and after grinding. Grinding with sandpaper or emery cloth is only advisable when, for example, carrying out shaft-repair on a lathe.
- 4. Needle Gunning**
- Needle gunning is mainly used for very rough cleaning or removal of rust. Needle gunning takes time and should be closely supervised. It is essential, that the marks from the sharp needles cover the entire surface, so that none of the original surface remains. It is recommendable to steam clean the surface before needle gunning. (see steam cleaning)
- 5. Machining**
- When carrying out mechanical repair jobs, using a lathe mill for turning is often the best and easiest way of preparing the surface. By repairing, for instance a worn shaft damaged by a loose roller bearing, using a lathe to a rough standard should be done prior to degreasing and application.

6. Steam cleaning An effective method of removing salt and oil remaining in the substrate is to use steam cleaning. Steam cleaners are available from most plant hire firms. Use steam temperature of approx. 95 °C and repeat the process three times, leaving the substrate to dry for some 15 minutes between each cleaning. Steam cleaning is not sufficient in itself. It must be followed by blasting or one of the other surface preparation methods.
7. Dehumidification A very simple and efficient method of removing moisture, whether it be moisture in the metal or from wet shot-blasting, is dehumidifying. Even parts which appear to be completely dry, can contain large quantities of moisture. When coating tanks, or other totally or partly enclosed parts - large pumps, pipes, etc. - dehumidification is recommended, as humidity emanating may condense on the part and reduce the physical adherence. Dehumidification units (DU) in different types and capacity units can be rented in most places. Position the DU close to the substrate to be treated, and insert the tube carrying dry air into the tank or part. If the parts to be treated are numerous and small, make a tent of plastic sheets and feed the tent. A few hours of dehumidification is enough to obtain a dry and good surface ready for the application. A quality requirement of dehumidification, is that during the coating process there must be a temperature of minimum 3°C. above the point of condensation. The point of condensation temperature is the highest the part must have, when moisture from the surroundings falls on the part and condenses. The point of condensation is thus dependent upon the temperature of the part, the ambient temperature, and the relative humidity of the air. Instruments exist for measuring these values, and where the repair of large parts is concerned, conditions should be laid down regarding this, if the application is to be done by subcontractor or customer.
8. Steel brushing Cleaning by using a steel brush (by hand or on a machine) is not recommended. A steel brush leaves a polished surface, which will reduce the adhesion of Wencon or other products - paint etc.

Index - Chapter 5 / Application data sheets

Ballast tanks - corrosion.....	75
Bearing seat - oversized	77
Bellow repair	79
Bow Thruster tunnel - corrosion.....	81
Bushing seats - casting.....	83
Butterfly valve - corrosion.....	85
Coated Linings - damaged	87
Cooler end cover - corrosion.....	89
Cracks in cast iron.....	91
Crane, swivel ring - casting support.....	93
Deck - corrosion	95
Doubler plates on deck - fixation.....	97
Engine blocks, O-ring seat - corrosion.....	99
Engine, top land surface for wet liner	101
Engines, generators - Chocking.....	103
Engines, wet liners - corrosion	105
Exhaust systems - leaks	107
Flange - corrosion	109
Flange faces, bushings etc. - hard seal.....	111
Fresh water generators - corrosion.....	113
Hatch covers, sealing surface - corrosion.....	115
Hot pipes - protection	117
Hydraulic rams - repair of scores.....	119
Inert gas systems - lining	121
Non-slip coating of rollers.....	123
Non-slip surface floors - stairs, drive rollers etc.	125
Pipe ends and flanges - coating	127
Pipe repair - ballast pipes	129
Pipe repair - cable pipes.....	131
Pipe repair - cargo pipe.....	133
Pipe repair - emergency.....	135

Index - Chapter 5 / Continued

Pipe repair - heating coils	137
Pipe repair - heating coils upper tank area	139
Pipe repair - high pressure pipes.....	141
Pipe repair - sea water pipe.....	143
Pumps split-case, sealing seat - corrosion.....	145
Pumps, casing cover - corrosion	147
Pumps, side cover - corrosion.....	149
Rudder heel bushing - casting of seat.....	151
Rudder heel pin, derrick - oversized.....	153
Rudder tail shaft / stock - coating	155
Rudder stock / shaft - scored	157
Rudder stock bearing - casting of seat.....	159
Rudder stock cone application.....	161
Rudder stock cone application.....	163
Sea water filters housing - corrosion.....	165
Sealing ring seats - corrosion	167
Shafts - damaged	169
Stern tubes - casting of seats	171
Tank holes - not leaking	173
Tanks - emergency repair of leaking cracks	175
Tanks - pitting.....	177
Tube end plates - corrosion.....	179
Turbo charger casings - sealing cracks.....	181
Valve seat - corrosion	183
Wear plates - casting support	185
Wheel house aluminium - corrosion	187

Ballast tanks - corrosion

APPLICATION DATA SHEET No. 144

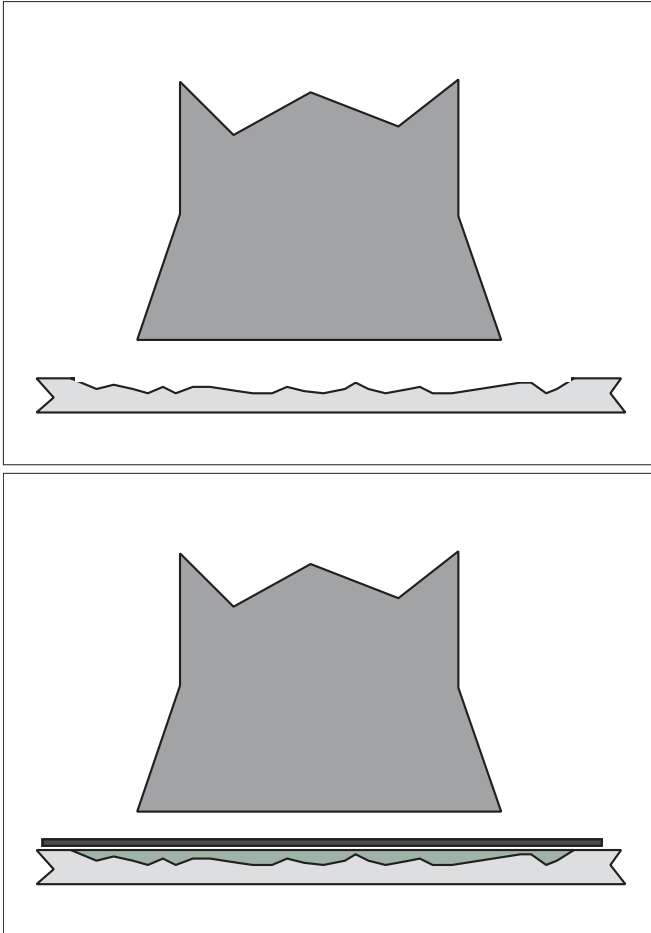

- Pump inlet
- Steel plate
- Corroded area
- Wencon Cream or Rapid
- Wencon Coating

Steel construction near the inlet of a pump often suffers from erosion/corrosion and impingement. If the deterioration has reached a point, where the thickness of steel plates is critically small, doublers should be welded in before this treatment.

1. Clean the area around the inlets thoroughly acc. to Wencon surface preparation, next page.
2. Mix and apply a suitable amount of Wencon Cream or Rapid to rebuild the damaged area. Let it cure until the surface is stiff but still slightly tacky.
3. Mix and apply Wencon Coating white, with brush or spatula, see instructions for use. Let it cure for approx. one hour.
4. Apply the final coat of Wencon Coating, blue and after the application is cured.

If a general tank coating shall be applied on top of the repaired area, it is advisable to grind the cured, glossy surface for better adhesion. Alternatively, if the tank coating is epoxy based, it can be applied shortly after the final coating, and make an excellent adhesion.

Alternative - wet surface

If the repair has to take place during normal traffic, it will be difficult to dry the surface before applying. In this case it is very convenient to use Wencon UW Cream and Wencon UW Coating, which give a good adhesion.

Alternative products: Wencon Ceramic products

Wencon surface preparation

Choose the relevant surface preparation, depending on the nature of the job.

Surface preparation using dry blasting methods:

Application with Wencon products on a dry surface, at minimum 3°C above dew point.

1. Blast the machine part to SA 2,5 using sharp-edged blasting media, to a roughness of min. 75 microns.
2. Leave the part for sweating out salts in a warm place for at least 12 hours or heat it up to 30 - 40°C (86-104 °F) using gas torches.
3. Blast again to SA 2,5, prior to the application.
4. For parts containing a lot of water and salt, it may be necessary to repeat point 2 and 3, until the surface remains light grey, for at least 2 hours after blasting.
5. For optimal adhesion of Wencon products, always use Wencon Bio Cleaner or Wencon Cleaner prior to application. Follow one of below two methods:
 - 5.1 **Wencon Bio Cleaner**
Wet surface: Apply Wencon Bio Cleaner and let it work for 5-10 min. If necessary use a brush, to make sure the surface is clean. Rinse off with clean water and wipe off with an absorbing cloth.

Dry surface: Apply Wencon Bio Cleaner and let it work for 5-10 min. If necessary use a brush, to make sure the surface is clean. Rinse off with clean water and dry with an absorbing cloth or with compressed air for a completely dry surface. Hereafter any Wencon products can be applied.
 - 5.2 **Wencon Cleaner**
 After surface preparation, apply Wencon Cleaner with a brush and allow the product to evaporate before applying other Wencon products. Wencon Cleaner is non-flammable. Use only in large or well ventilated rooms.

Surface preparation using wet/damp methods:

Water jet the entire surface with water and sand to a standard equal, to SA 2,5 as described above.

If the surface is left wet after surface preparation, is it important to dry out the surface or alternatively use a Wencon UW product.

Surface preparation for emergency/temporary applications:

If above surface preparation methods are not possible, it may be necessary to use one of below methods:

- Blasting
- Grinding
- Needle Gunning

In emergency / temporary applications it may be difficult to prepare the surface according to above methods. In any case, it is important to clean the surface to SA 2,5 and 75 microns roughness. If possible dry the surface before applying. If not possible, use Wencon UW products.

For further information on Wencon surface preparation, please contact our Area Sales Managers.

Bearing seat - oversized

APPLICATION DATA SHEET No. 103

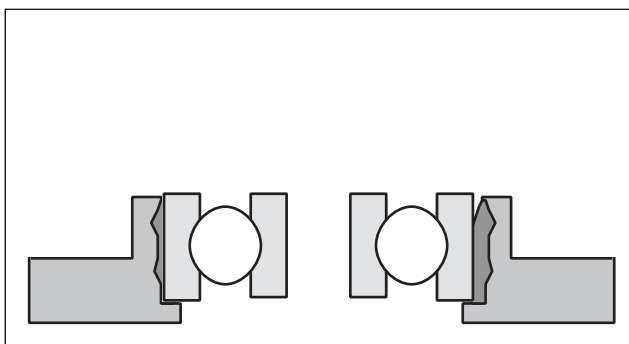
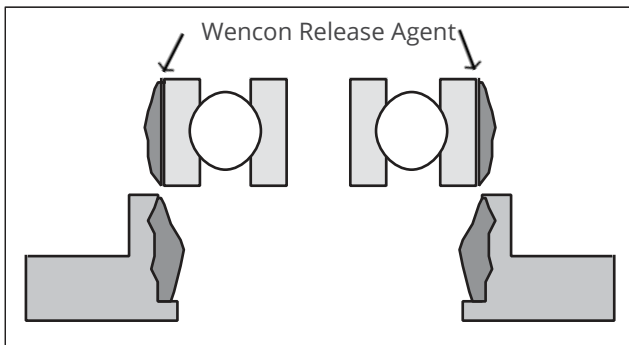
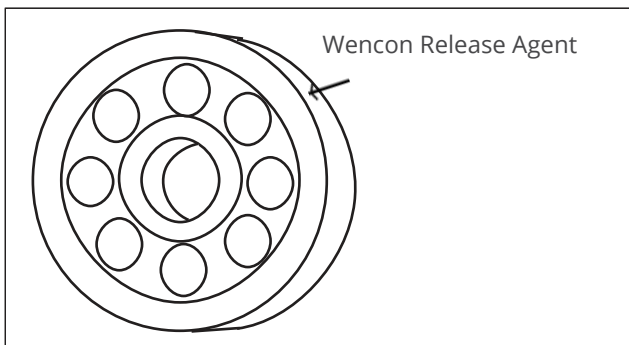
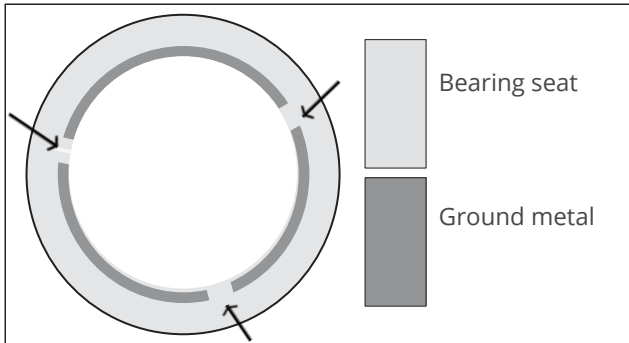

1. Remove the old bearing. Degrease the bearing seat acc. to Wencon surface preparation. Mark out three locations (note the arrows) which must not be ground. The purpose of these marks is to ensure good centring. Grind between these locations approx. 0.5-1,0 mm (0,02- 0,04 inch) into the metal. Clean again acc. to Wencon surface preparation, next page.
2. Apply a thin layer of Wencon Release Agent to the new bearing. Allow to dry for approx. five minutes, then wipe clean until only a film is left.
3. Mix and apply an adequate layer of Wencon Cream or Rapid to both the bearing seat and the bearing itself.
4. Position the bearing correctly in the seat and allow curing. Please refer also to directions for use.

The repaired bearing seat has a compressive strength 7-12 times higher than normally required.

Variations:

Seats for bushings are repaired in the same way.

This type of work can also be carried out in a turning lathe. All Wencon products are fully machinable after curing.

In some cases it may be an advantage to use a purpose made mandrel to do the casting.

Wencon surface preparation

Choose the relevant surface preparation, depending on the nature of the job.

Surface preparation using dry blasting methods:

Application with Wencon products on a dry surface, at minimum 3°C above dew point.

1. Blast the machine part to SA 2,5 using sharp-edged blasting media, to a roughness of min. 75 microns.
2. Leave the part for sweating out salts in a warm place for at least 12 hours or heat it up to 30 - 40°C (86-104 °F) using gas torches.
3. Blast again to SA 2,5, prior to the application.
4. For parts containing a lot of water and salt, it may be necessary to repeat point 2 and 3, until the surface remains light grey, for at least 2 hours after blasting.
5. For optimal adhesion of Wencon products, always use Wencon Bio Cleaner or Wencon Cleaner prior to application. Follow one of below two methods:
 - 5.1 **Wencon Bio Cleaner**
Wet surface: Apply Wencon Bio Cleaner and let it work for 5-10 min. If necessary use a brush, to make sure the surface is clean. Rinse off with clean water and wipe off with an absorbing cloth.

Dry surface: Apply Wencon Bio Cleaner and let it work for 5-10 min. If necessary use a brush, to make sure the surface is clean. Rinse off with clean water and dry with an absorbing cloth or with compressed air for a completely dry surface. Hereafter any Wencon products can be applied.
 - 5.2 **Wencon Cleaner**
After surface preparation, apply Wencon Cleaner with a brush and allow the product to evaporate before applying other Wencon products. Wencon Cleaner is non-flammable. Use only in large or well ventilated rooms.

Surface preparation using wet/damp methods:

Water jet the entire surface with water and sand to a standard equal, to SA 2,5 as described above.

If the surface is left wet after surface preparation, is it important to dry out the surface or alternatively use a Wencon UW product.

Surface preparation for emergency/temporary applications:

If above surface preparation methods are not possible, it may be necessary to use one of below methods:

- Blasting
- Grinding
- Needle Gunning

In emergency / temporary applications it may be difficult to prepare the surface according to above methods. In any case, it is important to clean the surface to SA 2,5 and 75 microns roughness. If possible dry the surface before applying. If not possible, use Wencon UW products.

For further information on Wencon surface preparation, please contact our Area Sales Managers.

Bellow repair

APPLICATION DATA SHEET No. 155

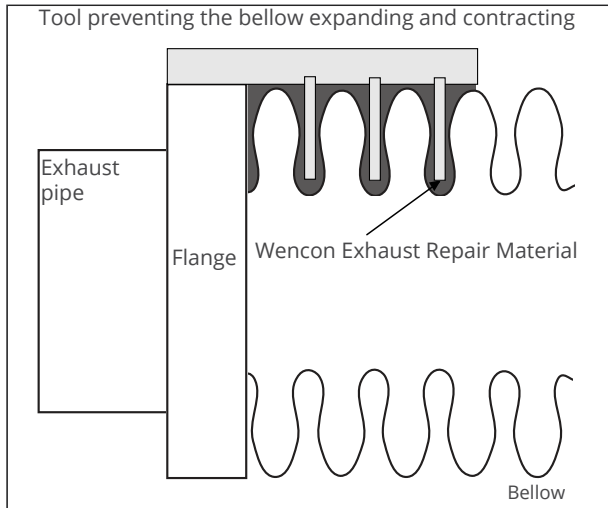

Repair of Bellow can be done as an emergency repair. Below description will guide you through the steps.

1. Prepare pieces of iron that shall prevent the bellow to move in the area, in which they are inserted.
2. Prepare one or more pieces of iron, onto which you weld the pieces mentioned in 1. in order to hold them in position.
3. Apply the Wencon Exhaust Repair material into the grooves of the bellow.
4. Before it cures, put your tool as mentioned above into the wet material and weld it to the flange or the like, depending on how it looks.
5. Let the Exhaust Repair material cure as long time as possible. If it is not allowed to cure enough, the gas will leak again.

Important:

This repair is temporary, until a new bellow can be mounted.

Wencon surface preparation

Choose the relevant surface preparation, depending on the nature of the job.

Surface preparation using dry blasting methods:

Application with Wencon products on a dry surface, at minimum 3°C above dew point.

1. Blast the machine part to SA 2,5 using sharp-edged blasting media, to a roughness of min. 75 microns.
2. Leave the part for sweating out salts in a warm place for at least 12 hours or heat it up to 30 - 40°C (86-104 °F) using gas torches.
3. Blast again to SA 2,5, prior to the application.
4. For parts containing a lot of water and salt, it may be necessary to repeat point 2 and 3, until the surface remains light grey, for at least 2 hours after blasting.
5. For optimal adhesion of Wencon products, always use Wencon Bio Cleaner or Wencon Cleaner prior to application. Follow one of below two methods:
 - 5.1 **Wencon Bio Cleaner**
Wet surface: Apply Wencon Bio Cleaner and let it work for 5-10 min. If necessary use a brush, to make sure the surface is clean. Rinse off with clean water and wipe off with an absorbing cloth.

Dry surface: Apply Wencon Bio Cleaner and let it work for 5-10 min. If necessary use a brush, to make sure the surface is clean. Rinse off with clean water and dry with an absorbing cloth or with compressed air for a completely dry surface. Hereafter any Wencon products can be applied.
 - 5.2 **Wencon Cleaner**
 After surface preparation, apply Wencon Cleaner with a brush and allow the product to evaporate before applying other Wencon products. Wencon Cleaner is non-flammable. Use only in large or well ventilated rooms.

Surface preparation using wet/damp methods:

Water jet the entire surface with water and sand to a standard equal, to SA 2,5 as described above.

If the surface is left wet after surface preparation, is it important to dry out the surface or alternatively use a Wencon UW product.

Surface preparation for emergency/temporary applications:

If above surface preparation methods are not possible, it may be necessary to use one of below methods:

- Blasting
- Grinding
- Needle Gunning

In emergency / temporary applications it may be difficult to prepare the surface according to above methods. In any case, it is important to clean the surface to SA 2,5 and 75 microns roughness. If possible dry the surface before applying. If not possible, use Wencon UW products.

For further information on Wencon surface preparation, please contact our Area Sales Managers.

Bow Thruster tunnel - corrosion

APPLICATION DATA SHEET No. 156

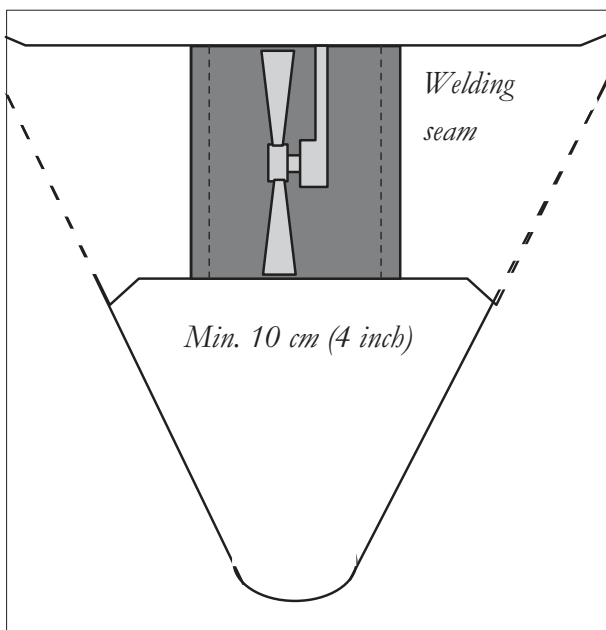
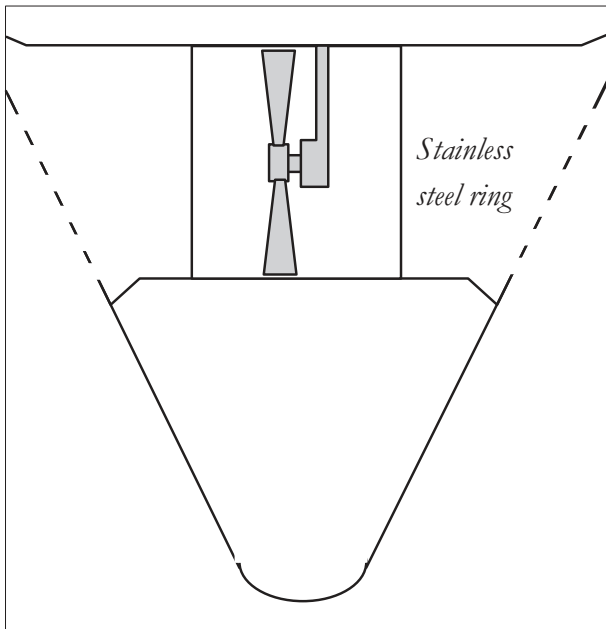

The Bow thruster tunnel can be suffering from bi-metallic corrosion. The reason is the mix of many different metals in that area, such as mild steel, the stainless steel band, bronze head / propeller etc.

The area is easy to repair and to protect against bi-metallic corrosion, by rebuilding the pittings with Wencon Rapid, and by applying a protective layer of Wencon Coating.

1. Blast the area to SA 2,5. All the attacked areas have to be blasted - at least to 10 cm on each side of the welding seams for the stainless steel band. Clean acc. to Wencon surface preparation, next page.
2. Rebuild the surface to original dimensions using Wencon Cream or Wencon Rapid. Making sure that all pittings are filled out.
3. Apply the first layer of Wencon Coating while the first layer is tacky, and let it semi-cure.
4. Mix and apply the third layer, using Wencon Coating, while the second layer is still tacky and let it cure.
4. The tunnel can be painted with a common ship paint here after to have an even colour.

Bow Thruster Heads suffering from bi-metallic corrosion can be repaired using this same method.

Alternative products: Wencon Ceramic products

Wencon surface preparation

Choose the relevant surface preparation, depending on the nature of the job.

Surface preparation using dry blasting methods:

Application with Wencon products on a dry surface, at minimum 3°C above dew point.

1. Blast the machine part to SA 2,5 using sharp-edged blasting media, to a roughness of min. 75 microns.
2. Leave the part for sweating out salts in a warm place for at least 12 hours or heat it up to 30 - 40°C (86-104 °F) using gas torches.
3. Blast again to SA 2,5, prior to the application.
4. For parts containing a lot of water and salt, it may be necessary to repeat point 2 and 3, until the surface remains light grey, for at least 2 hours after blasting.
5. For optimal adhesion of Wencon products, always use Wencon Bio Cleaner or Wencon Cleaner prior to application. Follow one of below two methods:
 - 5.1 **Wencon Bio Cleaner**
Wet surface: Apply Wencon Bio Cleaner and let it work for 5-10 min. If necessary use a brush, to make sure the surface is clean. Rinse off with clean water and wipe off with an absorbing cloth.

Dry surface: Apply Wencon Bio Cleaner and let it work for 5-10 min. If necessary use a brush, to make sure the surface is clean. Rinse off with clean water and dry with an absorbing cloth or with compressed air for a completely dry surface. Hereafter any Wencon products can be applied.
 - 5.2 **Wencon Cleaner**
 After surface preparation, apply Wencon Cleaner with a brush and allow the product to evaporate before applying other Wencon products. Wencon Cleaner is non-flammable. Use only in large or well ventilated rooms.

Surface preparation using wet/damp methods:

Water jet the entire surface with water and sand to a standard equal, to SA 2,5 as described above.

If the surface is left wet after surface preparation, is it important to dry out the surface or alternatively use a Wencon UW product.

Surface preparation for emergency/temporary applications:

If above surface preparation methods are not possible, it may be necessary to use one of below methods:

- Blasting
- Grinding
- Needle Gunning

In emergency / temporary applications it may be difficult to prepare the surface according to above methods. In any case, it is important to clean the surface to SA 2,5 and 75 microns roughness. If possible dry the surface before applying. If not possible, use Wencon UW products.

For further information on Wencon surface preparation, please contact our Area Sales Managers.

Bushing seats - casting

APPLICATION DATA SHEET No. 140

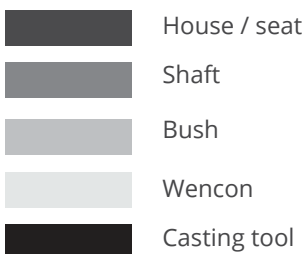
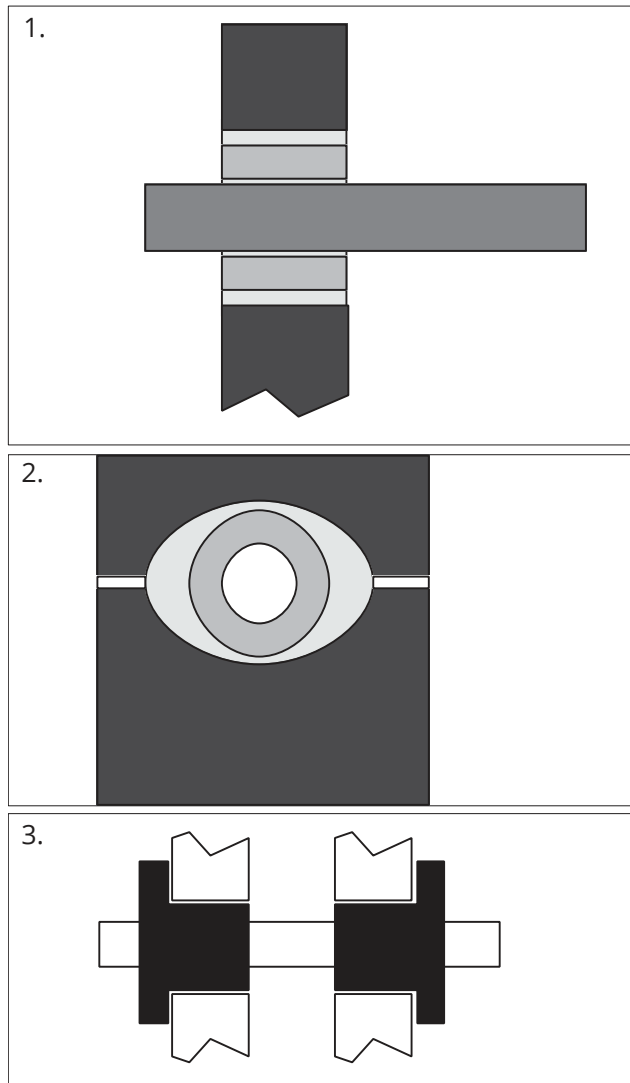

Casting of seats for bushings, bearings, etc. provide some advantages, compared to more conventional techniques.

1. Remove the old bushing or bearing. Grind and prepare the surface acc. to Wencon surface preparation, next page.

To secure easy disassembly, apply a thin film of Wencon Release Agent on the bushing or bearing.

Basically, there are two different ways of making the application, injecting the material after having mounted the bushing or by applying the material before the bushing is mounted.

2. & 3. Drill holes in the bushing seat as shown in ill. 3. Mount the bushing and hold it in position (typically by inserting the shaft).

Mix a suitable amount of Wencon Cream or Rapid and fill it into an empty cartridge for the injection gun (cartridges can be supplied by Wencon).

The gap between the seat and the bushing can easily be sealed with Wencon Putty. In some cases it is more convenient to drill the holes in the bushing.

If the bushing is not available, the seat can be cast using a casting tool, made to the right measures. See ill 3.

The technique is as described above. Less accurate is the technique, where you apply the Wencon Cream or Rapid to the surface of the bushing as well as into the seat.

Hereafter the bushing is inserted and the centred with the shaft or a tool made for it.

Wencon surface preparation

Choose the relevant surface preparation, depending on the nature of the job.

Surface preparation using dry blasting methods:

Application with Wencon products on a dry surface, at minimum 3°C above dew point.

1. Blast the machine part to SA 2,5 using sharp-edged blasting media, to a roughness of min. 75 microns.
2. Leave the part for sweating out salts in a warm place for at least 12 hours or heat it up to 30 - 40°C (86-104 °F) using gas torches.
3. Blast again to SA 2,5, prior to the application.
4. For parts containing a lot of water and salt, it may be necessary to repeat point 2 and 3, until the surface remains light grey, for at least 2 hours after blasting.
5. For optimal adhesion of Wencon products, always use Wencon Bio Cleaner or Wencon Cleaner prior to application. Follow one of below two methods:
 - 5.1 **Wencon Bio Cleaner**
Wet surface: Apply Wencon Bio Cleaner and let it work for 5-10 min. If necessary use a brush, to make sure the surface is clean. Rinse off with clean water and wipe off with an absorbing cloth.

Dry surface: Apply Wencon Bio Cleaner and let it work for 5-10 min. If necessary use a brush, to make sure the surface is clean. Rinse off with clean water and dry with an absorbing cloth or with compressed air for a completely dry surface. Hereafter any Wencon products can be applied.
 - 5.2 **Wencon Cleaner**
After surface preparation, apply Wencon Cleaner with a brush and allow the product to evaporate before applying other Wencon products. Wencon Cleaner is non-flammable. Use only in large or well ventilated rooms.

Surface preparation using wet/damp methods:

Water jet the entire surface with water and sand to a standard equal, to SA 2,5 as described above.

If the surface is left wet after surface preparation, is it important to dry out the surface or alternatively use a Wencon UW product.

Surface preparation for emergency/temporary applications:

If above surface preparation methods are not possible, it may be necessary to use one of below methods:

- Blasting
- Grinding
- Needle Gunning

In emergency / temporary applications it may be difficult to prepare the surface according to above methods. In any case, it is important to clean the surface to SA 2,5 and 75 microns roughness. If possible dry the surface before applying. If not possible, use Wencon UW products.

For further information on Wencon surface preparation, please contact our Area Sales Managers.

Butterfly valve - corrosion

APPLICATION DATA SHEET No. 127

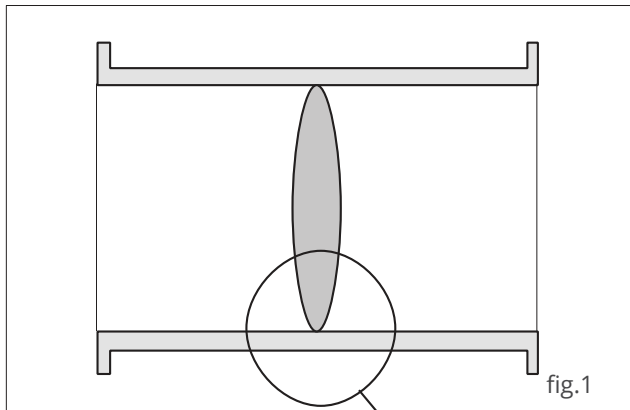

fig.1

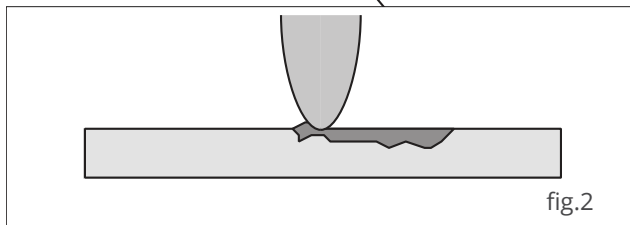

fig.2

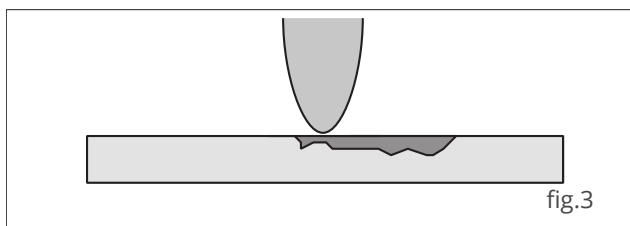
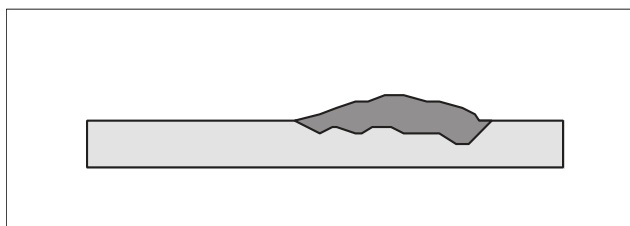

fig.3

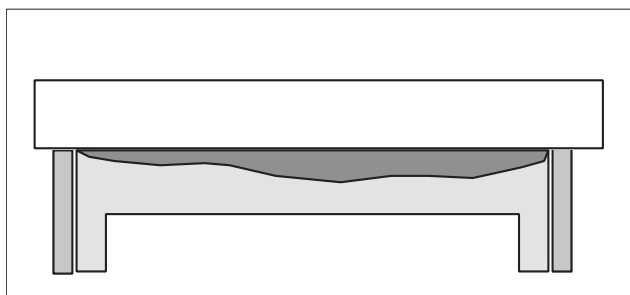

fig.4

Valves are normally repaired due to bimetallic corrosion or erosion / corrosion. In both cases, the surface preparation is very important.

Carry out surface preparation, acc. to Wencon surface preparation, next page.

Method 1

Open the valve, and apply Wencon Release Agent on the valve plate.

Mix and apply a suitable amount of Wencon Cream or Rapid into the corroded area in the valve housing and close the valve.

A perfect fit between the plate and the housing is hereby created, see fig. 1. After curing, open the valve and grind away excess material. If the plate is corroded, this must be repaired prior to the housing.

After the repair, the entire surface should be coated with Wencon Coating to prevent further corrosion.

Method 2

Disassemble the valve, and grit blast the parts.

Apply Wencon Cream or Rapid to the corroded areas (or the whole internal surface), leave it for curing and machine it to the right measures.

After machining, apply Wencon Coating to prevent future damage.

If the housing is badly corroded, it can be advantageous to make two plywood "flanges" to help give the right surface inside.

Use a big template / matrice for the application see fig. 4.

Wencon surface preparation

Choose the relevant surface preparation, depending on the nature of the job.

Surface preparation using dry blasting methods:

Application with Wencon products on a dry surface, at minimum 3°C above dew point.

1. Blast the machine part to SA 2,5 using sharp-edged blasting media, to a roughness of min. 75 microns.
2. Leave the part for sweating out salts in a warm place for at least 12 hours or heat it up to 30 - 40°C (86-104 °F) using gas torches.
3. Blast again to SA 2,5, prior to the application.
4. For parts containing a lot of water and salt, it may be necessary to repeat point 2 and 3, until the surface remains light grey, for at least 2 hours after blasting.
5. For optimal adhesion of Wencon products, always use Wencon Bio Cleaner or Wencon Cleaner prior to application. Follow one of below two methods:
 - 5.1 **Wencon Bio Cleaner**
Wet surface: Apply Wencon Bio Cleaner and let it work for 5-10 min. If necessary use a brush, to make sure the surface is clean. Rinse off with clean water and wipe off with an absorbing cloth.

Dry surface: Apply Wencon Bio Cleaner and let it work for 5-10 min. If necessary use a brush, to make sure the surface is clean. Rinse off with clean water and dry with an absorbing cloth or with compressed air for a completely dry surface. Hereafter any Wencon products can be applied.
 - 5.2 **Wencon Cleaner**
 After surface preparation, apply Wencon Cleaner with a brush and allow the product to evaporate before applying other Wencon products. Wencon Cleaner is non-flammable. Use only in large or well ventilated rooms.

Surface preparation using wet/damp methods:

Water jet the entire surface with water and sand to a standard equal, to SA 2,5 as described above.

If the surface is left wet after surface preparation, is it important to dry out the surface or alternatively use a Wencon UW product.

Surface preparation for emergency/temporary applications:

If above surface preparation methods are not possible, it may be necessary to use one of below methods:

- Blasting
- Grinding
- Needle Gunning

In emergency / temporary applications it may be difficult to prepare the surface according to above methods. In any case, it is important to clean the surface to SA 2,5 and 75 microns roughness. If possible dry the surface before applying. If not possible, use Wencon UW products.

For further information on Wencon surface preparation, please contact our Area Sales Managers.

Coated Linings - damaged

APPLICATION DATA SHEET No. 112

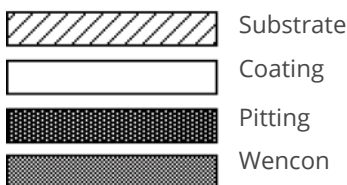
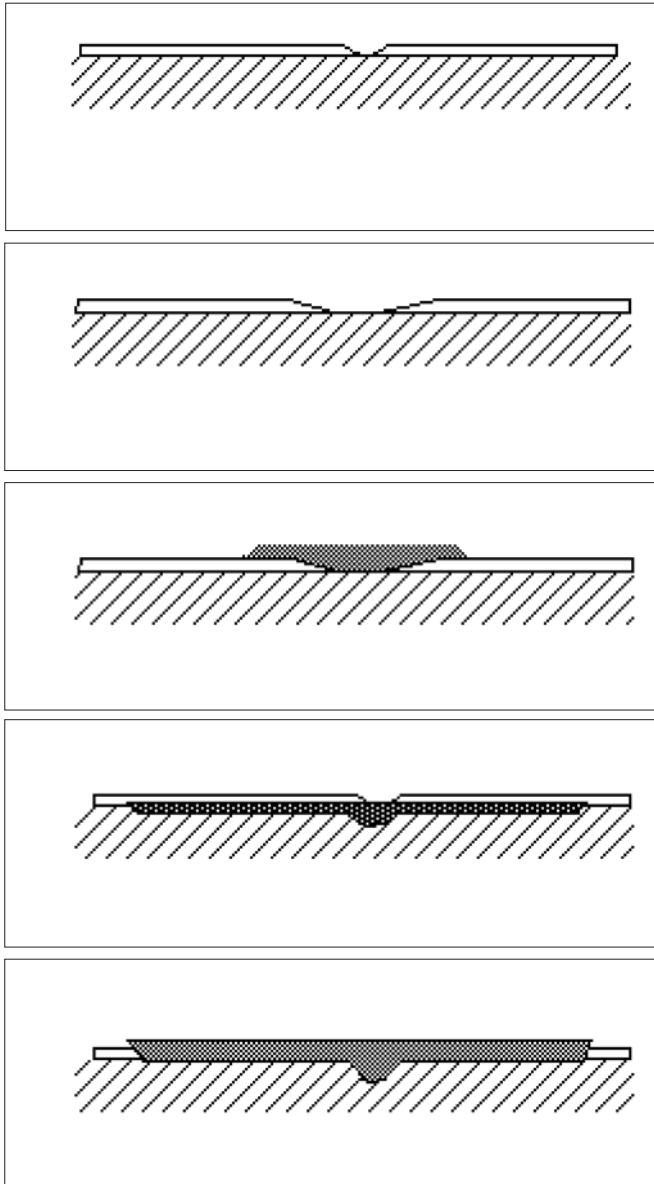

Damaged coated linings, such as castor oil based nylon and/or epoxy powder coatings often require a quick solution, to avoid substantial damage to the substrate.

Grind or grit blast the surface in and around the crack and in an overlap zone. Clean the area thoroughly acc. to Wencon surface preparation, next page.

Mix and apply a suitable amount of Wencon Hi-Temp. If a quick curing is required, heat the area using a hot air gun or Halogen lamp.

Variations

If larger parts of the powder coating has loosened, remove all the loose coating before the application is made.

If the damage is deeper than approx. 1 mm, use Wencon Cream or Wencon Rapid to build up the surface prior to coating with Wencon Hi-Temp.

If the damaged area is located near a flange, see Application Data Sheet No. 106 on page 119 for further instructions.

Wencon Hi-Temp is resistant to water, salt water, oil and the most diluted acids and alkalis.

Wencon surface preparation

Choose the relevant surface preparation, depending on the nature of the job.

Surface preparation using dry blasting methods:

Application with Wencon products on a dry surface, at minimum 3°C above dew point.

1. Blast the machine part to SA 2,5 using sharp-edged blasting media, to a roughness of min. 75 microns.
2. Leave the part for sweating out salts in a warm place for at least 12 hours or heat it up to 30 - 40°C (86-104 °F) using gas torches.
3. Blast again to SA 2,5, prior to the application.
4. For parts containing a lot of water and salt, it may be necessary to repeat point 2 and 3, until the surface remains light grey, for at least 2 hours after blasting.
5. For optimal adhesion of Wencon products, always use Wencon Bio Cleaner or Wencon Cleaner prior to application. Follow one of below two methods:
 - 5.1 **Wencon Bio Cleaner**
Wet surface: Apply Wencon Bio Cleaner and let it work for 5-10 min. If necessary use a brush, to make sure the surface is clean. Rinse off with clean water and wipe off with an absorbing cloth.

Dry surface: Apply Wencon Bio Cleaner and let it work for 5-10 min. If necessary use a brush, to make sure the surface is clean. Rinse off with clean water and dry with an absorbing cloth or with compressed air for a completely dry surface. Hereafter any Wencon products can be applied.
 - 5.2 **Wencon Cleaner**
 After surface preparation, apply Wencon Cleaner with a brush and allow the product to evaporate before applying other Wencon products. Wencon Cleaner is non-flammable. Use only in large or well ventilated rooms.

Surface preparation using wet/damp methods:

Water jet the entire surface with water and sand to a standard equal, to SA 2,5 as described above.

If the surface is left wet after surface preparation, is it important to dry out the surface or alternatively use a Wencon UW product.

Surface preparation for emergency/temporary applications:

If above surface preparation methods are not possible, it may be necessary to use one of below methods:

- Blasting
- Grinding
- Needle Gunning

In emergency / temporary applications it may be difficult to prepare the surface according to above methods. In any case, it is important to clean the surface to SA 2,5 and 75 microns roughness. If possible dry the surface before applying. If not possible, use Wencon UW products.

For further information on Wencon surface preparation, please contact our Area Sales Managers.

Cooler end cover - corrosion

APPLICATION DATA SHEET No. 105

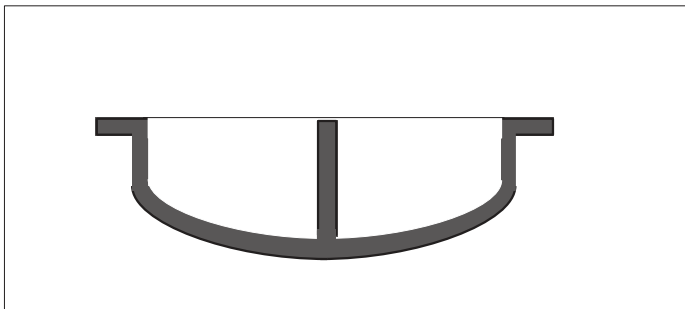
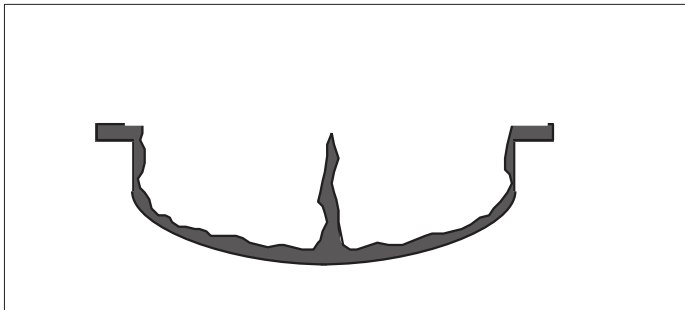
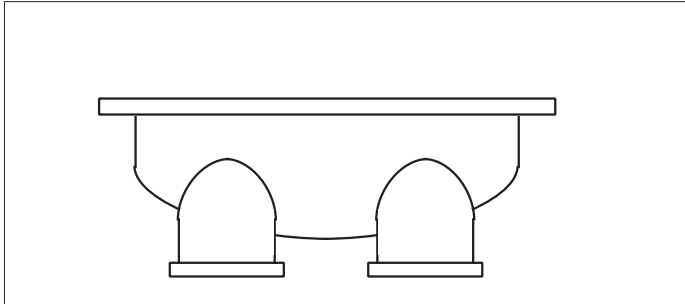

1. Disassemble the end cover and carry out the surface preparation acc. to Wencon surface preparation, next page.
2. Build up the end cover to its original shape with Wencon Cream or Rapid. If there are holes in the metal, in the outer sides or in the division bar, it will be an advantage to reinforce the repair with Wencon Reinforcement Tape or a piece of metal mesh. The metal mesh is particularly advantageous with big holes, as the rigidity of the mesh, eases the application.

Apply the Wencon well beyond the edges, and after curing grind away the surplus with a wheel grinder.

3. Build up also the edge of the division bar and prior to curing fit and tighten in place a piece of angle iron or the like, on the flanges, in such a manner that the division bar is given its required shape. The iron rail is treated with Wencon Release Agent before tightening in place.
4. After rebuilding to its original dimensions and semi curing, apply a layer of Wencon Coating, white over the entire end cover.
5. Allow to cure for 1-2 hours, then finish with a the final layer of Wencon Coating, blue.

Alternative repairs

If the end cover is corroded only on the packing surface of the division bar, the repair is done by grinding and cleaning this, applying thereafter a coat of Wencon Rapid, followed by a coat of release agent on the tube end plate. Mount the end cover before curing takes place. The packing surface will then be shaped automatically.

Wencon surface preparation

Choose the relevant surface preparation, depending on the nature of the job.

Surface preparation using dry blasting methods:

Application with Wencon products on a dry surface, at minimum 3°C above dew point.

1. Blast the machine part to SA 2,5 using sharp-edged blasting media, to a roughness of min. 75 microns.
2. Leave the part for sweating out salts in a warm place for at least 12 hours or heat it up to 30 - 40°C (86-104 °F) using gas torches.
3. Blast again to SA 2,5, prior to the application.
4. For parts containing a lot of water and salt, it may be necessary to repeat point 2 and 3, until the surface remains light grey, for at least 2 hours after blasting.
5. For optimal adhesion of Wencon products, always use Wencon Bio Cleaner or Wencon Cleaner prior to application. Follow one of below two methods:
 - 5.1 **Wencon Bio Cleaner**
 Wet surface: Apply Wencon Bio Cleaner and let it work for 5-10 min. If necessary use a brush, to make sure the surface is clean. Rinse off with clean water and wipe off with an absorbing cloth.

 Dry surface: Apply Wencon Bio Cleaner and let it work for 5-10 min. If necessary use a brush, to make sure the surface is clean. Rinse off with clean water and dry with an absorbing cloth or with compressed air for a completely dry surface. Hereafter any Wencon products can be applied.
 - 5.2 **Wencon Cleaner**
 After surface preparation, apply Wencon Cleaner with a brush and allow the product to evaporate before applying other Wencon products. Wencon Cleaner is non-flammable. Use only in large or well ventilated rooms.

Surface preparation using wet/damp methods:

Water jet the entire surface with water and sand to a standard equal, to SA 2,5 as described above.

If the surface is left wet after surface preparation, is it important to dry out the surface or alternatively use a Wencon UW product.

Surface preparation for emergency/temporary applications:

If above surface preparation methods are not possible, it may be necessary to use one of below methods:

- Blasting
- Grinding
- Needle Gunning

In emergency / temporary applications it may be difficult to prepare the surface according to above methods. In any case, it is important to clean the surface to SA 2,5 and 75 microns roughness. If possible dry the surface before applying. If not possible, use Wencon UW products.

For further information on Wencon surface preparation, please contact our Area Sales Managers.

Cracks in cast iron

APPLICATION DATA SHEET No. 101

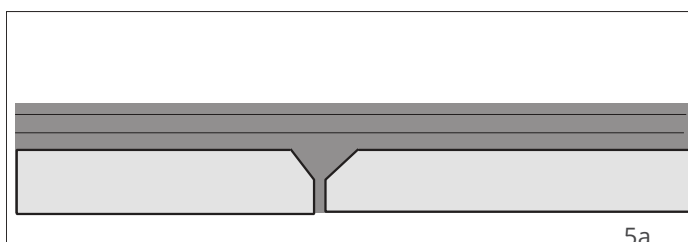
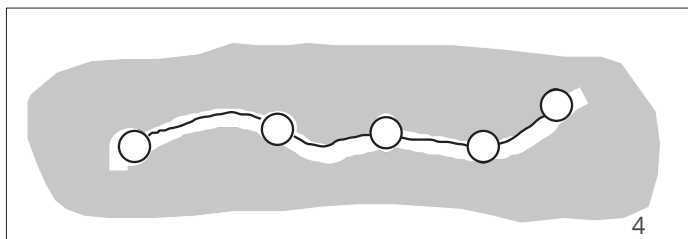
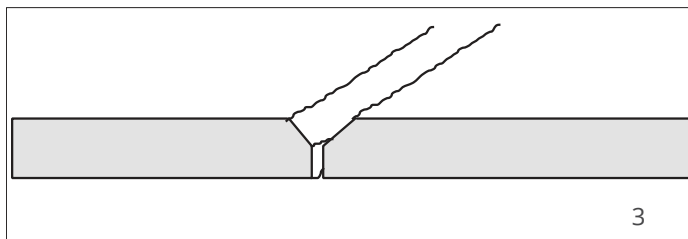
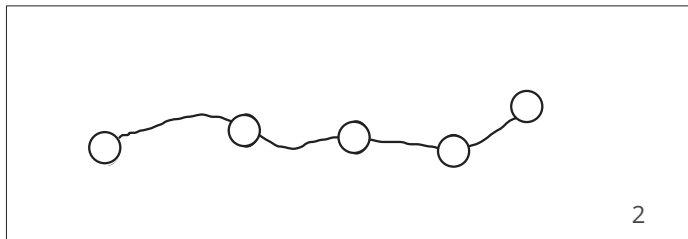
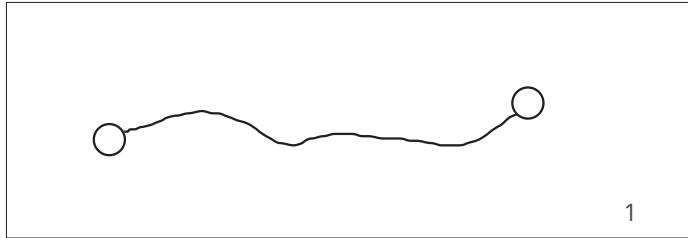

1. Drill a hole in each end of the crack, to prevent the crack elongating.
2. Drill holes (at least one) at 5 cm (2 inch) intervals, directly in the crack. Place a self-tapping screw in each hole (except for the two extreme positions) to prevent the crack from moving.
3. With an angle-grinder, grind a "V" directly in the crack. Also grind away the screw heads.
4. Grind the surface in a wide belt around the repair area and clean acc. to Wencon surface preparation, next page.
- 5.a Apply a thin layer (approx. 1 mm) of Wencon Cream (or Rapid). Place a piece of Wencon Reinforcement Tape in the layer, and apply 2-5 additional layers of Wencon Cream with Wencon Reinforcement Tape between the layers. Allow curing.
- 5.b If using a fixation plate, make corresponding holes in the fixation plate and push the anchor bolts through the plate and the holes, making sure that the anchor hooks up on the backside of the wall. Apply the Wencon product between the fixation plate and the wall and tighten it using the washers and the nuts.

Remarks

Make sure to prepare the backside of the fixation plate.

The purpose of this repair job is only to seal the crack, not provide physical strength.

Alternative products: Wencon UW Cream or Wencon Ceramic Cream

Wencon surface preparation

Choose the relevant surface preparation, depending on the nature of the job.

Surface preparation using dry blasting methods:

Application with Wencon products on a dry surface, at minimum 3°C above dew point.

1. Blast the machine part to SA 2,5 using sharp-edged blasting media, to a roughness of min. 75 microns.
2. Leave the part for sweating out salts in a warm place for at least 12 hours or heat it up to 30 - 40°C (86-104 °F) using gas torches.
3. Blast again to SA 2,5, prior to the application.
4. For parts containing a lot of water and salt, it may be necessary to repeat point 2 and 3, until the surface remains light grey, for at least 2 hours after blasting.
5. For optimal adhesion of Wencon products, always use Wencon Bio Cleaner or Wencon Cleaner prior to application. Follow one of below two methods:
 - 5.1 **Wencon Bio Cleaner**
Wet surface: Apply Wencon Bio Cleaner and let it work for 5-10 min. If necessary use a brush, to make sure the surface is clean. Rinse off with clean water and wipe off with an absorbing cloth.

Dry surface: Apply Wencon Bio Cleaner and let it work for 5-10 min. If necessary use a brush, to make sure the surface is clean. Rinse off with clean water and dry with an absorbing cloth or with compressed air for a completely dry surface. Hereafter any Wencon products can be applied.
 - 5.2 **Wencon Cleaner**
After surface preparation, apply Wencon Cleaner with a brush and allow the product to evaporate before applying other Wencon products. Wencon Cleaner is non-flammable. Use only in large or well ventilated rooms.

Surface preparation using wet/damp methods:

Water jet the entire surface with water and sand to a standard equal, to SA 2,5 as described above.

If the surface is left wet after surface preparation, is it important to dry out the surface or alternatively use a Wencon UW product.

Surface preparation for emergency/temporary applications:

If above surface preparation methods are not possible, it may be necessary to use one of below methods:

- Blasting
- Grinding
- Needle Gunning

In emergency / temporary applications it may be difficult to prepare the surface according to above methods. In any case, it is important to clean the surface to SA 2,5 and 75 microns roughness. If possible dry the surface before applying. If not possible, use Wencon UW products.

For further information on Wencon surface preparation, please contact our Area Sales Managers.

Crane, swivel ring - casting support

APPLICATION DATA SHEET No. 130

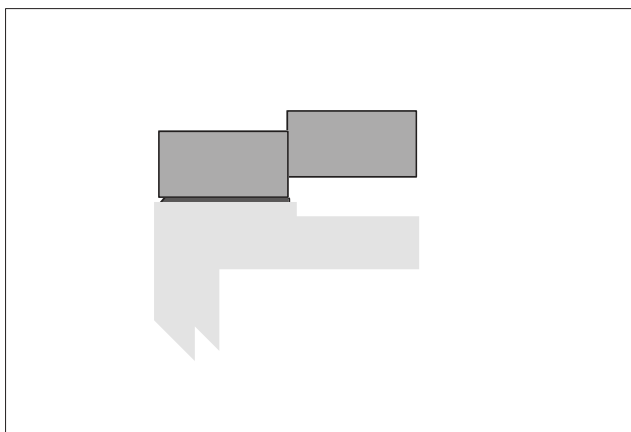
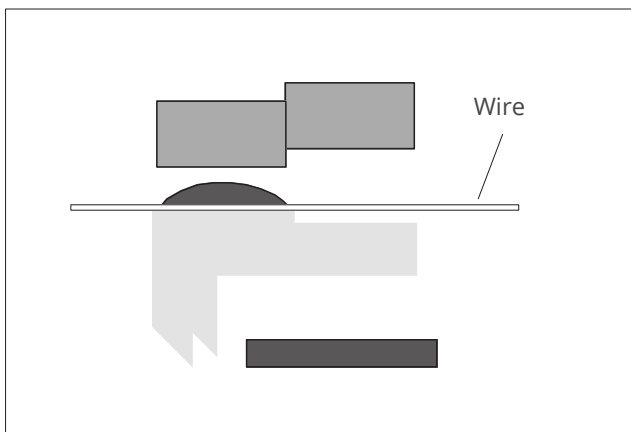
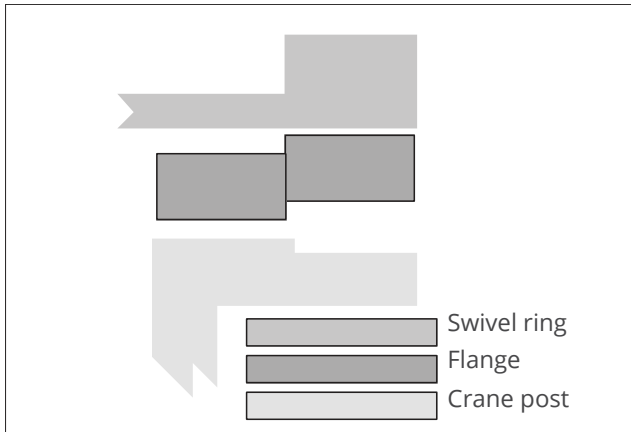

Prior to starting up the application, the compression of the swivel ring must be known.

The compressive tensile strength:
Wencon Rapid 58 N/mm sq. (Rcrack)
Wencon Cream 112 N/mm sq. (Rcrack)

1. Lift the swivel ring to enable surface preparation of the flange top. Grit blast and Clean the flange top using Wencon Cleaner.
2. Apply Wencon Release Agent to the bottom surfaces of the swivel ring. Allow to dry for 5-10 min., and remove excess release agent and thread the bolts.
3. Mix and apply a suitable amount of Wencon Cream. The final layer must be min. 2-3 mm (0,08-0,12 inch). To avoid air entrapment, apply thickest on the middle. For every 20 cm, place a 2 mm (0,08 inch) metal wire (welding electro de) across the flange to create an even casting.
4. Place the ring in position, and empty the bolt holes for Wencon material. Mount the bolts, but do not tighten them.
5. After curing, loosen the bolts, and take away the wire.

The job is done, and you can mount the swivel ring. If you have got air entrapment, these can be repaired easily, by grinding the dent, and fill it with Wencon Cream, let it cure and grind away excess material.

Wencon surface preparation

Choose the relevant surface preparation, depending on the nature of the job.

Surface preparation using dry blasting methods:

Application with Wencon products on a dry surface, at minimum 3°C above dew point.

1. Blast the machine part to SA 2,5 using sharp-edged blasting media, to a roughness of min. 75 microns.
2. Leave the part for sweating out salts in a warm place for at least 12 hours or heat it up to 30 - 40°C (86-104 °F) using gas torches.
3. Blast again to SA 2,5, prior to the application.
4. For parts containing a lot of water and salt, it may be necessary to repeat point 2 and 3, until the surface remains light grey, for at least 2 hours after blasting.
5. For optimal adhesion of Wencon products, always use Wencon Bio Cleaner or Wencon Cleaner prior to application. Follow one of below two methods:
 - 5.1 **Wencon Bio Cleaner**
Wet surface: Apply Wencon Bio Cleaner and let it work for 5-10 min. If necessary use a brush, to make sure the surface is clean. Rinse off with clean water and wipe off with an absorbing cloth.

Dry surface: Apply Wencon Bio Cleaner and let it work for 5-10 min. If necessary use a brush, to make sure the surface is clean. Rinse off with clean water and dry with an absorbing cloth or with compressed air for a completely dry surface. Hereafter any Wencon products can be applied.
 - 5.2 **Wencon Cleaner**
After surface preparation, apply Wencon Cleaner with a brush and allow the product to evaporate before applying other Wencon products. Wencon Cleaner is non-flammable. Use only in large or well ventilated rooms.

Surface preparation using wet/damp methods:

Water jet the entire surface with water and sand to a standard equal, to SA 2,5 as described above.

If the surface is left wet after surface preparation, is it important to dry out the surface or alternatively use a Wencon UW product.

Surface preparation for emergency/temporary applications:

If above surface preparation methods are not possible, it may be necessary to use one of below methods:

- Blasting
- Grinding
- Needle Gunning

In emergency / temporary applications it may be difficult to prepare the surface according to above methods. In any case, it is important to clean the surface to SA 2,5 and 75 microns roughness. If possible dry the surface before applying. If not possible, use Wencon UW products.

For further information on Wencon surface preparation, please contact our Area Sales Managers.

Deck - corrosion

APPLICATION DATA SHEET No. 132

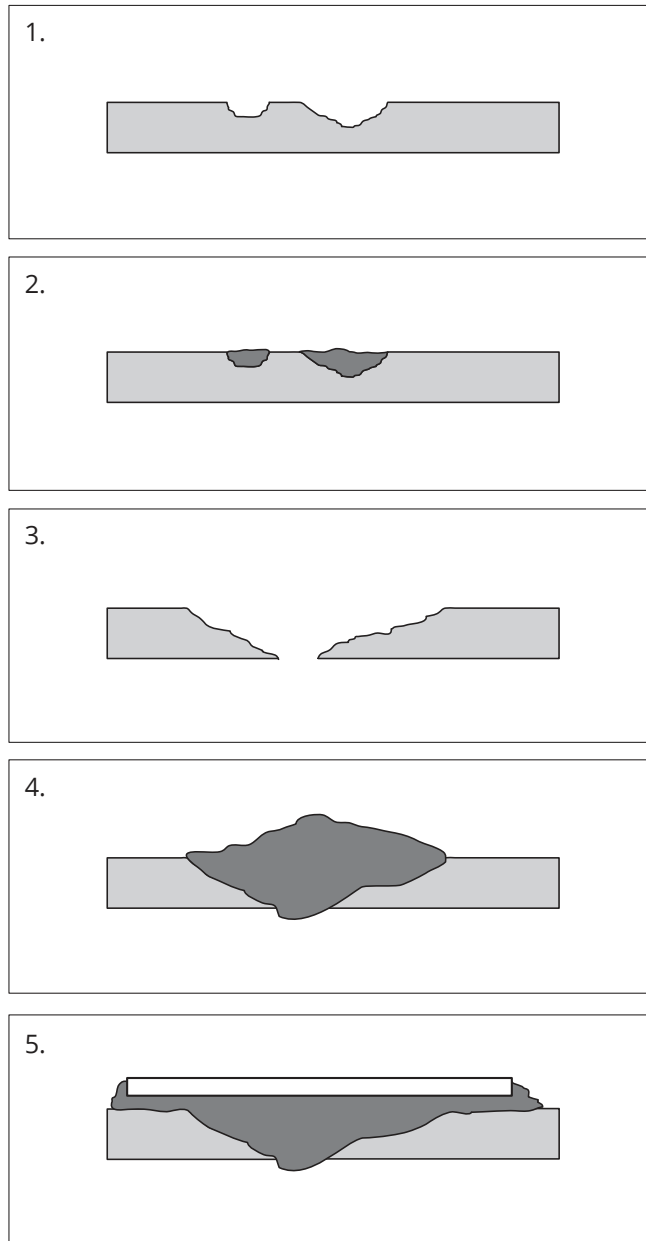

Corrosion attack on deck can be refurbished using Wencon Cream and Wencon Rapid. Wencon products have a penetration time of more than 15 years, and has an outstanding adhesion to metals.

1. Prepare the surfaces acc. to Wencon surface preparation, next page.
2. Mix and apply a suitable amount of Wencon Cream or Rapid, and leave it for curing. After curing 4 - 8 hours, it can be painted.
3. In situations, where the corrosion has come through the deck, it is advised to put on a doubler.
4. Apply a good amount of Wencon Cream or Wencon Rapid as shown.
5. Press firmly a small steel plate, already ground and degreased on one side, into the un-cured material, to provide strength.

Depending on thickness of the product applied, the product will be fully cured after 10-15 hours at 20°C (68° F). The product is machinable after curing.

Tip: If this application is finished off with a protective layer of i.e. Wencon Coating, the entire area will be given an added corrosion protection.

Wencon surface preparation

Choose the relevant surface preparation, depending on the nature of the job.

Surface preparation using dry blasting methods:

Application with Wencon products on a dry surface, at minimum 3°C above dew point.

1. Blast the machine part to SA 2,5 using sharp-edged blasting media, to a roughness of min. 75 microns.
2. Leave the part for sweating out salts in a warm place for at least 12 hours or heat it up to 30 - 40°C (86-104 °F) using gas torches.
3. Blast again to SA 2,5, prior to the application.
4. For parts containing a lot of water and salt, it may be necessary to repeat point 2 and 3, until the surface remains light grey, for at least 2 hours after blasting.
5. For optimal adhesion of Wencon products, always use Wencon Bio Cleaner or Wencon Cleaner prior to application. Follow one of below two methods:
 - 5.1 **Wencon Bio Cleaner**
Wet surface: Apply Wencon Bio Cleaner and let it work for 5-10 min. If necessary use a brush, to make sure the surface is clean. Rinse off with clean water and wipe off with an absorbing cloth.

Dry surface: Apply Wencon Bio Cleaner and let it work for 5-10 min. If necessary use a brush, to make sure the surface is clean. Rinse off with clean water and dry with an absorbing cloth or with compressed air for a completely dry surface. Hereafter any Wencon products can be applied.
 - 5.2 **Wencon Cleaner**
 After surface preparation, apply Wencon Cleaner with a brush and allow the product to evaporate before applying other Wencon products. Wencon Cleaner is non-flammable. Use only in large or well ventilated rooms.

Surface preparation using wet/damp methods:

Water jet the entire surface with water and sand to a standard equal, to SA 2,5 as described above.

If the surface is left wet after surface preparation, is it important to dry out the surface or alternatively use a Wencon UW product.

Surface preparation for emergency/temporary applications:

If above surface preparation methods are not possible, it may be necessary to use one of below methods:

- Blasting
- Grinding
- Needle Gunning

In emergency / temporary applications it may be difficult to prepare the surface according to above methods. In any case, it is important to clean the surface to SA 2,5 and 75 microns roughness. If possible dry the surface before applying. If not possible, use Wencon UW products.

For further information on Wencon surface preparation, please contact our Area Sales Managers.

Doubler plates on deck - fixation

APPLICATION DATA SHEET No. 131

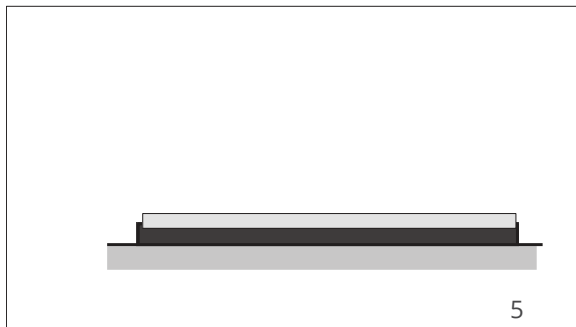
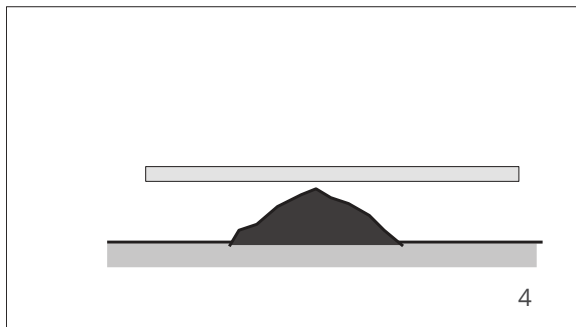
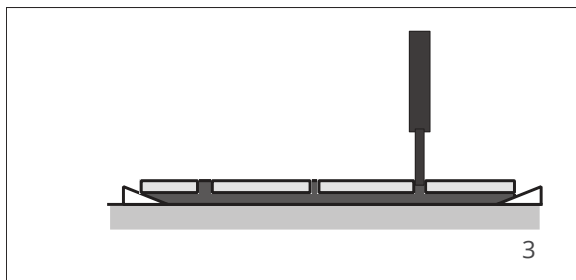
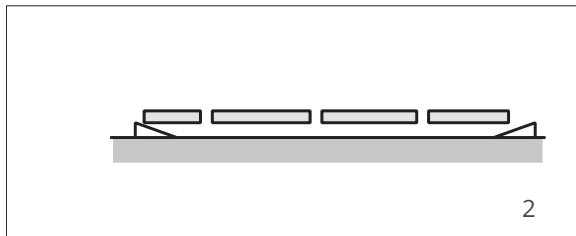
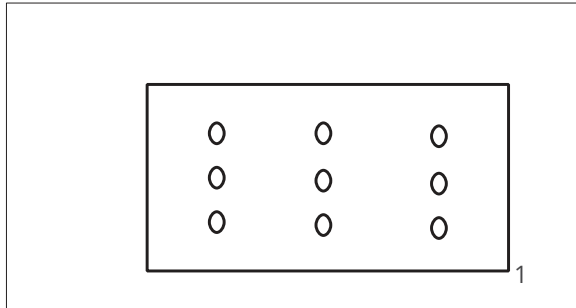

Often, it is not possible to fix a doubler by welding. For instance on a tank top.

Below find two methods for the application.

Method 1

1. Drill holes in the doubler 6-8 mm (0,24-0,32 inch) \varnothing for injection. Make one hole for every 400 cm sq. Grind or grit blast the mating surfaces acc. to Wencon surface preparation, next page.
2. Place the doubler on 4 wedges in the desired height min. 3-4 mm (0,12-0,16 inch).
3. Wencon Cream or Coating is mixed, filled into empty cartridges and injected through the holes. Begin in the middle area and work your way out. Make sure the gap being totally filled. After curing (see instructions leaflet) the job is finished.

Method 2

4. The job can be done avoiding the drilled holes. Mix and apply Wencon Cream or Rapid as shown in fig. 4. Make sure, that there is enough material to be squeezed out from the gap during the mounting.
5. Mount the doubler in the wet material and make sure, that excess material is being squeezed out all way round the plate to be sure of total fixation. It may be advantageous to apply a very thin layer of Wencon on both mating surfaces initially. Let it cure before loading.

Method 2 is the fastest, but has limitations with regards to the size of the doubler. If method 2 is used on very irregular surface, it is recommended, that Wencon Cream or Rapid should be used to create an even surface before the mounting. The larger doublers the more difficult it will be to press the plate in position.

Apply vibration by the means of a pneumatic hammer or the like on the top.

Wencon surface preparation

Choose the relevant surface preparation, depending on the nature of the job.

Surface preparation using dry blasting methods:

Application with Wencon products on a dry surface, at minimum 3°C above dew point.

1. Blast the machine part to SA 2,5 using sharp-edged blasting media, to a roughness of min. 75 microns.
2. Leave the part for sweating out salts in a warm place for at least 12 hours or heat it up to 30 - 40°C (86-104 °F) using gas torches.
3. Blast again to SA 2,5, prior to the application.
4. For parts containing a lot of water and salt, it may be necessary to repeat point 2 and 3, until the surface remains light grey, for at least 2 hours after blasting.
5. For optimal adhesion of Wencon products, always use Wencon Bio Cleaner or Wencon Cleaner prior to application. Follow one of below two methods:
 - 5.1 **Wencon Bio Cleaner**
Wet surface: Apply Wencon Bio Cleaner and let it work for 5-10 min. If necessary use a brush, to make sure the surface is clean. Rinse off with clean water and wipe off with an absorbing cloth.

Dry surface: Apply Wencon Bio Cleaner and let it work for 5-10 min. If necessary use a brush, to make sure the surface is clean. Rinse off with clean water and dry with an absorbing cloth or with compressed air for a completely dry surface. Hereafter any Wencon products can be applied.
 - 5.2 **Wencon Cleaner**
 After surface preparation, apply Wencon Cleaner with a brush and allow the product to evaporate before applying other Wencon products. Wencon Cleaner is non-flammable. Use only in large or well ventilated rooms.

Surface preparation using wet/damp methods:

Water jet the entire surface with water and sand to a standard equal, to SA 2,5 as described above.

If the surface is left wet after surface preparation, is it important to dry out the surface or alternatively use a Wencon UW product.

Surface preparation for emergency/temporary applications:

If above surface preparation methods are not possible, it may be necessary to use one of below methods:

- Blasting
- Grinding
- Needle Gunning

In emergency / temporary applications it may be difficult to prepare the surface according to above methods. In any case, it is important to clean the surface to SA 2,5 and 75 microns roughness. If possible dry the surface before applying. If not possible, use Wencon UW products.

For further information on Wencon surface preparation, please contact our Area Sales Managers.

Engine blocks, O-ring seat - corrosion

APPLICATION DATA SHEET No. 137

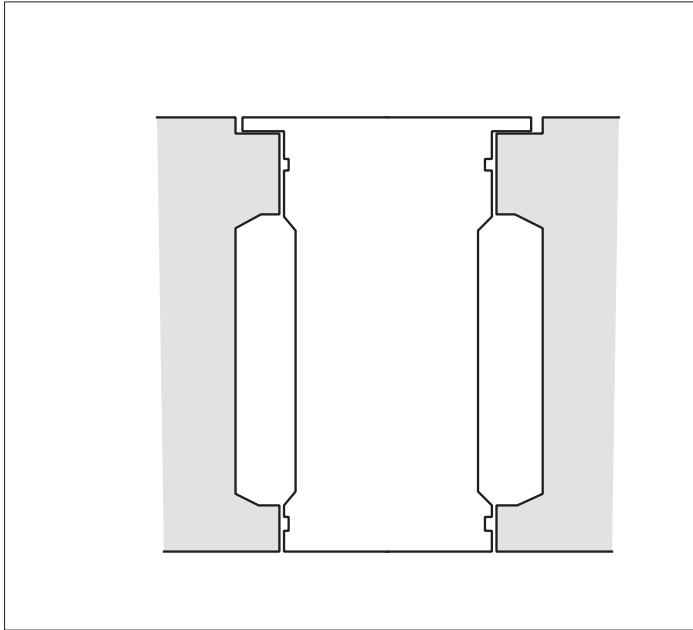

A typical example of a small damage, having a substantial effect is the corroding of the surface that supports an O-ring between the wet liner and the engine block.

In some engines, the O-ring seat is placed in the liner, in other engines in the block, but corrosion in the mating surface will always cause severe problems.

This technique is a good alternative to welding.

1. Remove the liner and clean the corroded areas thoroughly acc. to Wencon surface preparation, next page.
2. Mix and apply a suitable amount of Wencon Ceramic Cream or Ceramic Coating and leave the surface slightly proud.
3. Let the Wencon product cure according to the instructions for use.
4. Grind the surface back into original dimensions, using a grinding tool in the right shape.

TIP. Wencon Putty is very suitable for creating your own grinding tool in a correct shape: simply mix the product and mould it by hand.

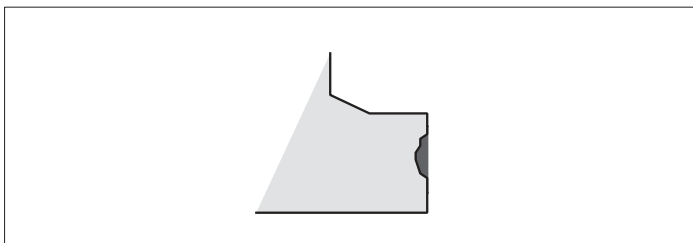
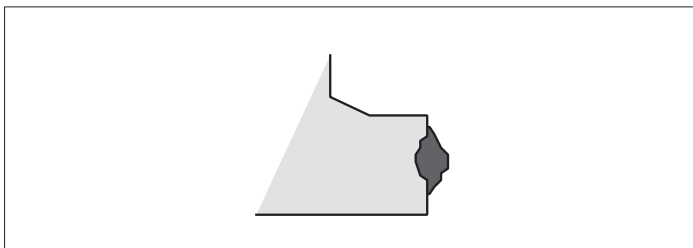
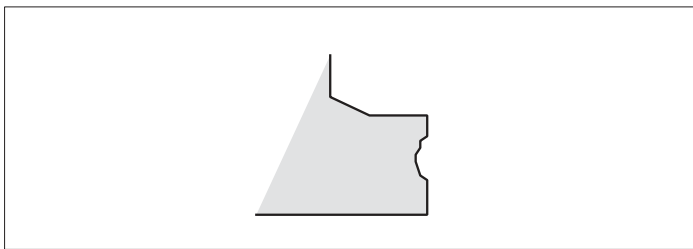

Alternative products: Wencon Hi-Temp

Wencon surface preparation

Choose the relevant surface preparation, depending on the nature of the job.

Surface preparation using dry blasting methods:

Application with Wencon products on a dry surface, at minimum 3°C above dew point.

1. Blast the machine part to SA 2,5 using sharp-edged blasting media, to a roughness of min. 75 microns.
2. Leave the part for sweating out salts in a warm place for at least 12 hours or heat it up to 30 - 40°C (86-104 °F) using gas torches.
3. Blast again to SA 2,5, prior to the application.
4. For parts containing a lot of water and salt, it may be necessary to repeat point 2 and 3, until the surface remains light grey, for at least 2 hours after blasting.
5. For optimal adhesion of Wencon products, always use Wencon Bio Cleaner or Wencon Cleaner prior to application. Follow one of below two methods:
 - 5.1 **Wencon Bio Cleaner**
Wet surface: Apply Wencon Bio Cleaner and let it work for 5-10 min. If necessary use a brush, to make sure the surface is clean. Rinse off with clean water and wipe off with an absorbing cloth.

Dry surface: Apply Wencon Bio Cleaner and let it work for 5-10 min. If necessary use a brush, to make sure the surface is clean. Rinse off with clean water and dry with an absorbing cloth or with compressed air for a completely dry surface. Hereafter any Wencon products can be applied.
 - 5.2 **Wencon Cleaner**
 After surface preparation, apply Wencon Cleaner with a brush and allow the product to evaporate before applying other Wencon products. Wencon Cleaner is non-flammable. Use only in large or well ventilated rooms.

Surface preparation using wet/damp methods:

Water jet the entire surface with water and sand to a standard equal, to SA 2,5 as described above.

If the surface is left wet after surface preparation, is it important to dry out the surface or alternatively use a Wencon UW product.

Surface preparation for emergency/temporary applications:

If above surface preparation methods are not possible, it may be necessary to use one of below methods:

- Blasting
- Grinding
- Needle Gunning

In emergency / temporary applications it may be difficult to prepare the surface according to above methods. In any case, it is important to clean the surface to SA 2,5 and 75 microns roughness. If possible dry the surface before applying. If not possible, use Wencon UW products.

For further information on Wencon surface preparation, please contact our Area Sales Managers.

Engine, top land surface for wet liner

- Corrosion

APPLICATION DATA SHEET No. 138

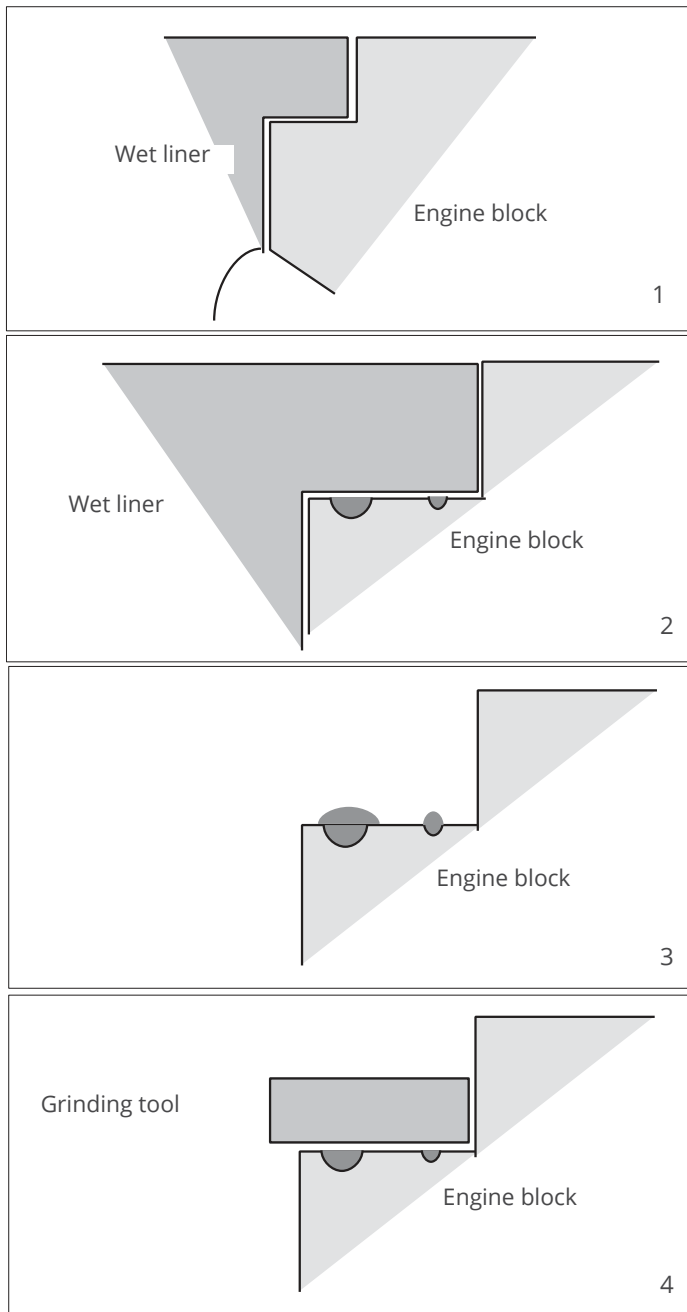

Problem:

Corrosion in top land surface for wet liners.

Purpose of application:

To prevent further corrosion in the pits and to prevent leakage.

1. Grind the pitting in the surface to bare metal using small rotating equipment.
2. Prepare the surface thoroughly acc. to Wencon surface preparation, next page.
3. Mix and apply a suitable amount of Wencon Ceramic Cream or Ceramic Coating to the affected areas, and leave the surface slightly proud, see ill. 3.
4. After semi-curing, cut most of the excess material away with a knife, and grind the surface with appropriate grinding tool as in ill. 4.

Neither sea water, nor oil will have damaging effect on the cured repair material.

Alternative products: Wencon Hi-Temp

Wencon surface preparation

Choose the relevant surface preparation, depending on the nature of the job.

Surface preparation using dry blasting methods:

Application with Wencon products on a dry surface, at minimum 3°C above dew point.

1. Blast the machine part to SA 2,5 using sharp-edged blasting media, to a roughness of min. 75 microns.
2. Leave the part for sweating out salts in a warm place for at least 12 hours or heat it up to 30 - 40°C (86-104 °F) using gas torches.
3. Blast again to SA 2,5, prior to the application.
4. For parts containing a lot of water and salt, it may be necessary to repeat point 2 and 3, until the surface remains light grey, for at least 2 hours after blasting.
5. For optimal adhesion of Wencon products, always use Wencon Bio Cleaner or Wencon Cleaner prior to application. Follow one of below two methods:
 - 5.1 **Wencon Bio Cleaner**
Wet surface: Apply Wencon Bio Cleaner and let it work for 5-10 min. If necessary use a brush, to make sure the surface is clean. Rinse off with clean water and wipe off with an absorbing cloth.

Dry surface: Apply Wencon Bio Cleaner and let it work for 5-10 min. If necessary use a brush, to make sure the surface is clean. Rinse off with clean water and dry with an absorbing cloth or with compressed air for a completely dry surface. Hereafter any Wencon products can be applied.
 - 5.2 **Wencon Cleaner**
 After surface preparation, apply Wencon Cleaner with a brush and allow the product to evaporate before applying other Wencon products. Wencon Cleaner is non-flammable. Use only in large or well ventilated rooms.

Surface preparation using wet/damp methods:

Water jet the entire surface with water and sand to a standard equal, to SA 2,5 as described above.

If the surface is left wet after surface preparation, is it important to dry out the surface or alternatively use a Wencon UW product.

Surface preparation for emergency/temporary applications:

If above surface preparation methods are not possible, it may be necessary to use one of below methods:

- Blasting
- Grinding
- Needle Gunning

In emergency / temporary applications it may be difficult to prepare the surface according to above methods. In any case, it is important to clean the surface to SA 2,5 and 75 microns roughness. If possible dry the surface before applying. If not possible, use Wencon UW products.

For further information on Wencon surface preparation, please contact our Area Sales Managers.

Engines, generators - Chocking

APPLICATION DATA SHEET No. 120

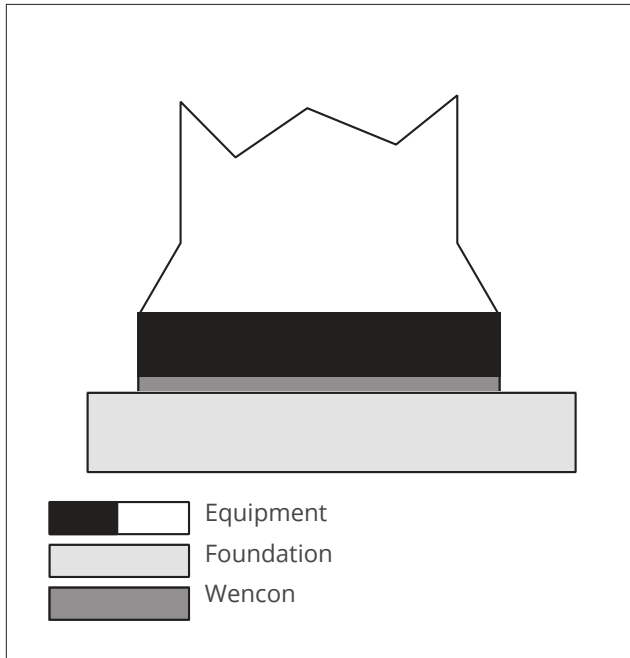

Chocking, grouting or casting of resins for the purpose of creating a strong connection between foundation and equipment, has become more common in the marine industry.

It is a very quick way of securing an engine, and specially when doing repair on a ship, the time consumption is of the greatest importance.

Wencon supplies a small and efficient range of products for these kind of applications. Wencon Cream is paste consistency for injection and Wencon Coating for pouring and injection.

The Wencon range is known for its quick curing and for the limited amount of product needed. Whilst most chocking compounds should be applied in a thickness of about 25-35 millimetres (1,0-1,4 inch), Wencon products will do with only 4-5 mm (0,16-0,2 inch) and still cure perfectly within a short time.

Wencon surface preparation

Choose the relevant surface preparation, depending on the nature of the job.

Surface preparation using dry blasting methods:

Application with Wencon products on a dry surface, at minimum 3°C above dew point.

1. Blast the machine part to SA 2,5 using sharp-edged blasting media, to a roughness of min. 75 microns.
2. Leave the part for sweating out salts in a warm place for at least 12 hours or heat it up to 30 - 40°C (86-104 °F) using gas torches.
3. Blast again to SA 2,5, prior to the application.
4. For parts containing a lot of water and salt, it may be necessary to repeat point 2 and 3, until the surface remains light grey, for at least 2 hours after blasting.
5. For optimal adhesion of Wencon products, always use Wencon Bio Cleaner or Wencon Cleaner prior to application. Follow one of below two methods:
 - 5.1 **Wencon Bio Cleaner**
Wet surface: Apply Wencon Bio Cleaner and let it work for 5-10 min. If necessary use a brush, to make sure the surface is clean. Rinse off with clean water and wipe off with an absorbing cloth.

Dry surface: Apply Wencon Bio Cleaner and let it work for 5-10 min. If necessary use a brush, to make sure the surface is clean. Rinse off with clean water and dry with an absorbing cloth or with compressed air for a completely dry surface. Hereafter any Wencon products can be applied.
 - 5.2 **Wencon Cleaner**
 After surface preparation, apply Wencon Cleaner with a brush and allow the product to evaporate before applying other Wencon products. Wencon Cleaner is non-flammable. Use only in large or well ventilated rooms.

Surface preparation using wet/damp methods:

Water jet the entire surface with water and sand to a standard equal, to SA 2,5 as described above.

If the surface is left wet after surface preparation, is it important to dry out the surface or alternatively use a Wencon UW product.

Surface preparation for emergency/temporary applications:

If above surface preparation methods are not possible, it may be necessary to use one of below methods:

- Blasting
- Grinding
- Needle Gunning

In emergency / temporary applications it may be difficult to prepare the surface according to above methods. In any case, it is important to clean the surface to SA 2,5 and 75 microns roughness. If possible dry the surface before applying. If not possible, use Wencon UW products.

For further information on Wencon surface preparation, please contact our Area Sales Managers.

Engines, wet liners - corrosion

APPLICATION DATA SHEET No. 134

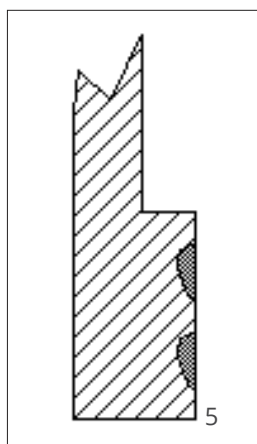
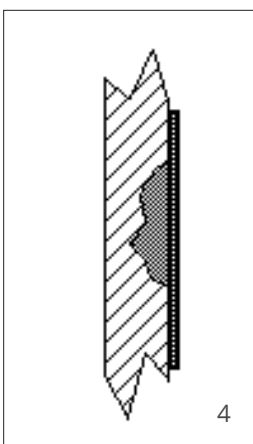
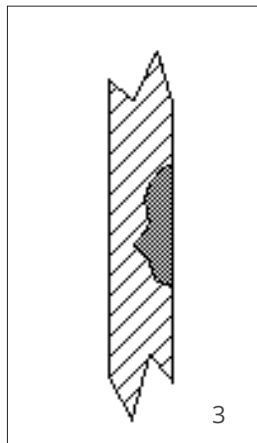
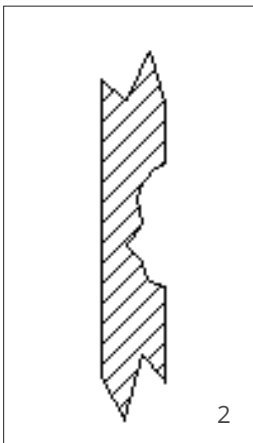
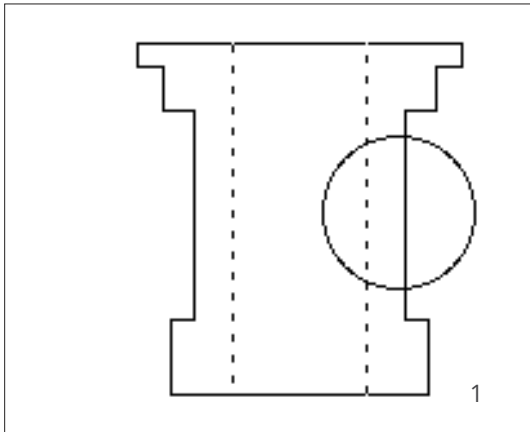

Usually, the sealing of the cooling water in an engine, is created by the means of O-rings. The O-ring seats will be positioned in either the liner or in the engine block. Both the O-ring seats and the sealing surface on the other part can corrode. Either bi-metallic or from the continuous rubbing of the O-ring.

In both cases the damage can be repaired with Wencon products.

1. Remove the liners from the engine, and protect the machined areas on the liner with tape.
2. Grit blast the affected areas acc. to Wencon surface preparation, next page.
3. Rebuild the affected areas to original dimensions using Wencon Ceramic products.
4. Coat the external surface of the liner, but avoid coating the machined surfaces in the engine block that are in direct contact with each other.

The coating with Wencon products will prevent the bi-metallic corrosion from arising again.

5. Use the same procedure as above, but machine the surface after the curing has taken place. The machining can be done in either a lathe or by carefully grinding with a wheel grinder. If the damage is on the block, the initial surface preparation cannot be done by grit blasting, but by grinding and degreasing with Wencon Cleaner.

Follow the instructions carefully and ask your supplier if you are in doubt.

Experience has shown that the treatment has no effect on the temperature of the cooling water.

Wencon provides solutions for:
Repairs in the engine wet liners.
Corrosion on the outside of the liner, and deterioration of the metal surface of the O-ring seats in either the top or the bottom.

Alternative products: Wencon Hi-Temp

Wencon surface preparation

Choose the relevant surface preparation, depending on the nature of the job.

Surface preparation using dry blasting methods:

Application with Wencon products on a dry surface, at minimum 3°C above dew point.

1. Blast the machine part to SA 2,5 using sharp-edged blasting media, to a roughness of min. 75 microns.
2. Leave the part for sweating out salts in a warm place for at least 12 hours or heat it up to 30 - 40°C (86-104 °F) using gas torches.
3. Blast again to SA 2,5, prior to the application.
4. For parts containing a lot of water and salt, it may be necessary to repeat point 2 and 3, until the surface remains light grey, for at least 2 hours after blasting.
5. For optimal adhesion of Wencon products, always use Wencon Bio Cleaner or Wencon Cleaner prior to application. Follow one of below two methods:
 - 5.1 **Wencon Bio Cleaner**
Wet surface: Apply Wencon Bio Cleaner and let it work for 5-10 min. If necessary use a brush, to make sure the surface is clean. Rinse off with clean water and wipe off with an absorbing cloth.

Dry surface: Apply Wencon Bio Cleaner and let it work for 5-10 min. If necessary use a brush, to make sure the surface is clean. Rinse off with clean water and dry with an absorbing cloth or with compressed air for a completely dry surface. Hereafter any Wencon products can be applied.
 - 5.2 **Wencon Cleaner**
After surface preparation, apply Wencon Cleaner with a brush and allow the product to evaporate before applying other Wencon products. Wencon Cleaner is non-flammable. Use only in large or well ventilated rooms.

Surface preparation using wet/damp methods:

Water jet the entire surface with water and sand to a standard equal, to SA 2,5 as described above.

If the surface is left wet after surface preparation, is it important to dry out the surface or alternatively use a Wencon UW product.

Surface preparation for emergency/temporary applications:

If above surface preparation methods are not possible, it may be necessary to use one of below methods:

- Blasting
- Grinding
- Needle Gunning

In emergency / temporary applications it may be difficult to prepare the surface according to above methods. In any case, it is important to clean the surface to SA 2,5 and 75 microns roughness. If possible dry the surface before applying. If not possible, use Wencon UW products.

For further information on Wencon surface preparation, please contact our Area Sales Managers.

Exhaust systems - leaks

APPLICATION DATA SHEET No. 147

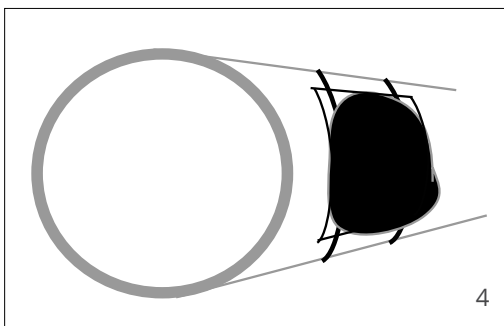
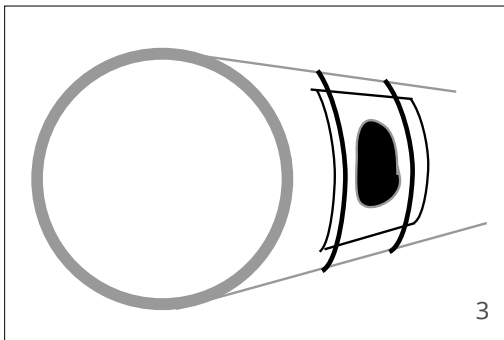
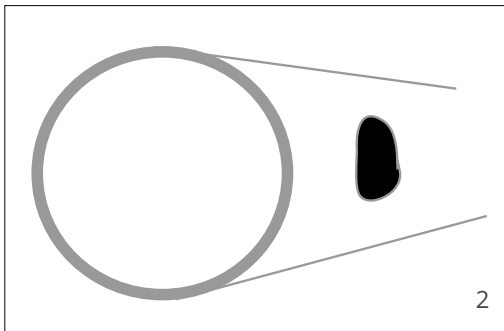
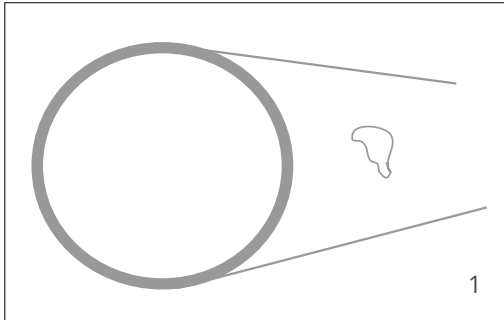

Cracks or leaks in exhaust systems must be repaired by using a compound with a very high temperature resistance.

Wencon Exhaust Repair Compound is a one component product, with a temperature resistance of 1000°C (1832°F), which is ideal for this type of application.

1. Grind and clean the affected and the surrounding area thoroughly acc. to Wencon surface preparation, next page.
2. Open one of the tubs containing the product (remember this is a one component). Stir it to an even consistency. Apply a suitable amount in and around the leak.
3. Cut a suitable piece of the metal mesh and fix it to the repair area using steel band or steel wires.
4. Apply second layer of the compound and leave it for initial curing for 3-4 hours, depending on temperature and humidity. When the compound has turned hard, heat it up slowly to approx. 95°C (200°F) and leave it at that temp. for 15 minutes to fully cure.

Remarks

It is important to note, that this product is designed for emergency repair of leaks.

Read Wencon Safety Data Sheet before using the product.

Wencon surface preparation

Choose the relevant surface preparation, depending on the nature of the job.

Surface preparation using dry blasting methods:

Application with Wencon products on a dry surface, at minimum 3°C above dew point.

1. Blast the machine part to SA 2,5 using sharp-edged blasting media, to a roughness of min. 75 microns.
2. Leave the part for sweating out salts in a warm place for at least 12 hours or heat it up to 30 - 40°C (86-104 °F) using gas torches.
3. Blast again to SA 2,5, prior to the application.
4. For parts containing a lot of water and salt, it may be necessary to repeat point 2 and 3, until the surface remains light grey, for at least 2 hours after blasting.
5. For optimal adhesion of Wencon products, always use Wencon Bio Cleaner or Wencon Cleaner prior to application. Follow one of below two methods:
 - 5.1 **Wencon Bio Cleaner**
Wet surface: Apply Wencon Bio Cleaner and let it work for 5-10 min. If necessary use a brush, to make sure the surface is clean. Rinse off with clean water and wipe off with an absorbing cloth.

Dry surface: Apply Wencon Bio Cleaner and let it work for 5-10 min. If necessary use a brush, to make sure the surface is clean. Rinse off with clean water and dry with an absorbing cloth or with compressed air for a completely dry surface. Hereafter any Wencon products can be applied.
 - 5.2 **Wencon Cleaner**
After surface preparation, apply Wencon Cleaner with a brush and allow the product to evaporate before applying other Wencon products. Wencon Cleaner is non-flammable. Use only in large or well ventilated rooms.

Surface preparation using wet/damp methods:

Water jet the entire surface with water and sand to a standard equal, to SA 2,5 as described above.

If the surface is left wet after surface preparation, is it important to dry out the surface or alternatively use a Wencon UW product.

Surface preparation for emergency/temporary applications:

If above surface preparation methods are not possible, it may be necessary to use one of below methods:

- Blasting
- Grinding
- Needle Gunning

In emergency / temporary applications it may be difficult to prepare the surface according to above methods. In any case, it is important to clean the surface to SA 2,5 and 75 microns roughness. If possible dry the surface before applying. If not possible, use Wencon UW products.

For further information on Wencon surface preparation, please contact our Area Sales Managers.

Flange - corrosion

APPLICATION DATA SHEET No. 126

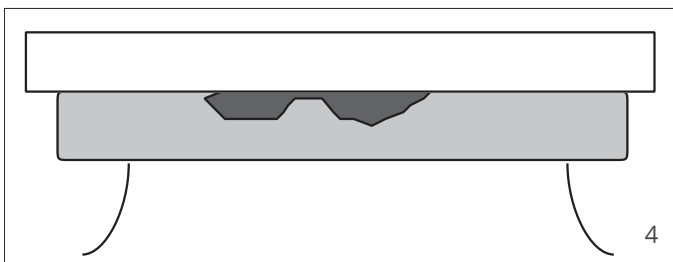
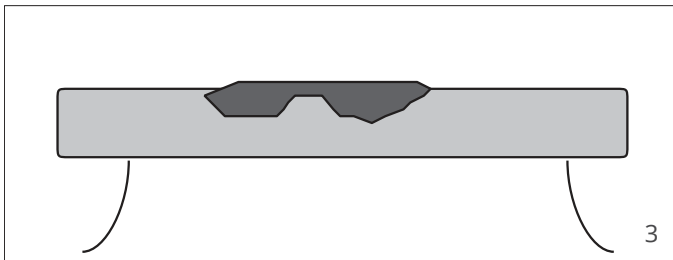
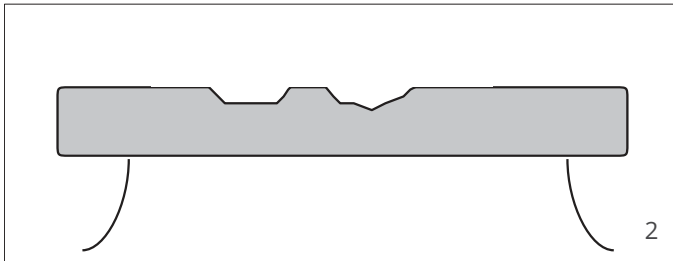
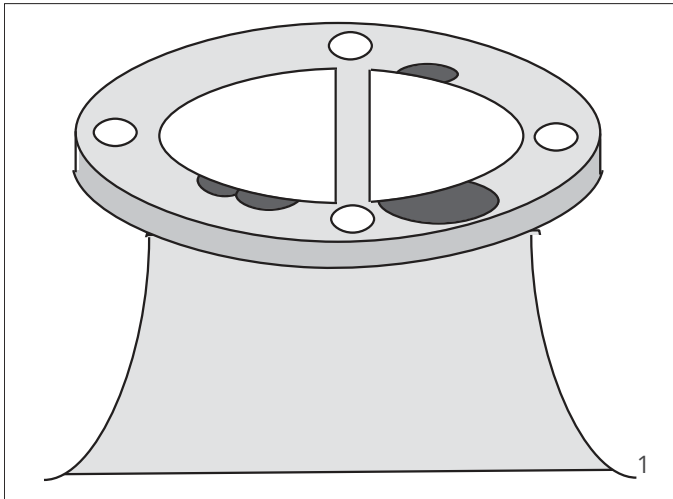

1. Corroded flanges can be repaired, using Wencon Cream or Wencon Rapid. The optimal surface preparation is to grit blast the flange, applying Wencon Cream or Wencon Rapid. Then letting it cure, and machine the flange to size. But optimal conditions are not always available, therefore below is a guide on how to do the application **on site**.
2. Dismantle the flange, clean and degrease the affected areas thoroughly using Wencon Cleaner, and any method available to get the surface roughened.
3. Apply a suitable layer of Wencon Cream or Wencon Rapid on the corroded area.
4. Mount and hold a template/matrice to the flange until it has fully cured. The template can be made in thick plastic plate (polyethylene) to avoid the use of release agent. If it is made of metal, use Wencon Release Agent on the template to avoid adhesion.
5. After curing, remove the template, and re-shape the holes in the flange using a round file.

If a number of flanges on i.e. a manifold needs repair, it is important that the entire surface is in line. Use a large enough template to cove all flanges at the same time. It is also possible to use the engine, as the mating surface/template.

NB: It is important to use Wencon Release Agent when using a template or matrice, or the two surfaces will be fused together. And after curing to remove any excess material.

Alternative products: Wencon Ceramic products

Wencon surface preparation

Choose the relevant surface preparation, depending on the nature of the job.

Surface preparation using dry blasting methods:

Application with Wencon products on a dry surface, at minimum 3°C above dew point.

1. Blast the machine part to SA 2,5 using sharp-edged blasting media, to a roughness of min. 75 microns.
2. Leave the part for sweating out salts in a warm place for at least 12 hours or heat it up to 30 - 40°C (86-104 °F) using gas torches.
3. Blast again to SA 2,5, prior to the application.
4. For parts containing a lot of water and salt, it may be necessary to repeat point 2 and 3, until the surface remains light grey, for at least 2 hours after blasting.
5. For optimal adhesion of Wencon products, always use Wencon Bio Cleaner or Wencon Cleaner prior to application. Follow one of below two methods:
 - 5.1 **Wencon Bio Cleaner**
Wet surface: Apply Wencon Bio Cleaner and let it work for 5-10 min. If necessary use a brush, to make sure the surface is clean. Rinse off with clean water and wipe off with an absorbing cloth.

Dry surface: Apply Wencon Bio Cleaner and let it work for 5-10 min. If necessary use a brush, to make sure the surface is clean. Rinse off with clean water and dry with an absorbing cloth or with compressed air for a completely dry surface. Hereafter any Wencon products can be applied.
 - 5.2 **Wencon Cleaner**
 After surface preparation, apply Wencon Cleaner with a brush and allow the product to evaporate before applying other Wencon products. Wencon Cleaner is non-flammable. Use only in large or well ventilated rooms.

Surface preparation using wet/damp methods:

Water jet the entire surface with water and sand to a standard equal, to SA 2,5 as described above.

If the surface is left wet after surface preparation, is it important to dry out the surface or alternatively use a Wencon UW product.

Surface preparation for emergency/temporary applications:

If above surface preparation methods are not possible, it may be necessary to use one of below methods:

- Blasting
- Grinding
- Needle Gunning

In emergency / temporary applications it may be difficult to prepare the surface according to above methods. In any case, it is important to clean the surface to SA 2,5 and 75 microns roughness. If possible dry the surface before applying. If not possible, use Wencon UW products.

For further information on Wencon surface preparation, please contact our Area Sales Managers.

Flange faces, bushings etc. - hard seal

APPLICATION DATA SHEET No. 133

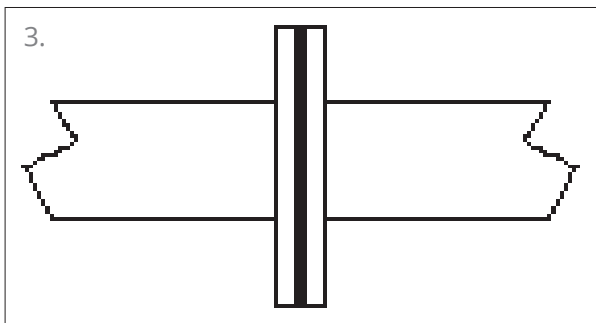
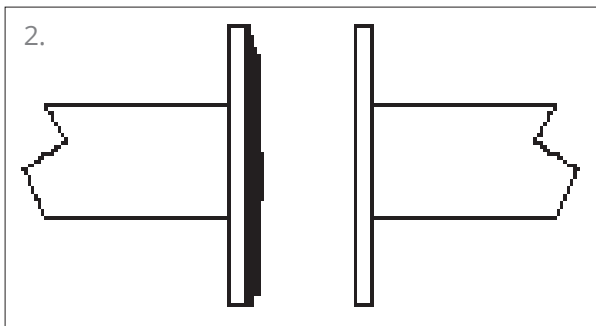
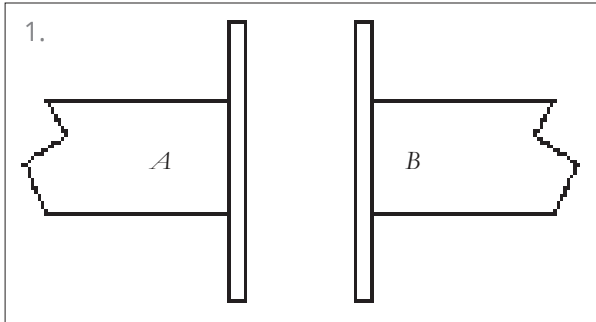

Wencon offers a very easy, quick and long lasting technique for restoring and creating mating surfaces on i.e. flange faces, bushing seats, conical couplings of shafts and/or pipes, condensers, heat exchangers, bearing seats, etc.

Suitable products:

Wencon Cream: cures in 10-15 hrs.

Wencon Rapid: cures in 90 min.

Wencon Ceramic Cream: High strength

Wencon UW Cream: Can be applied in wet

Follow below procedure:

1. Clean flange A using a wheel grinder and the Wencon Bio Cleaner. Clean flange B using only Wencon Bio Cleaner. See Wencon surface preparation, next page.
2. Apply a thin film of Wencon Release Agent on flange B, and let it dry for ten minutes. Mix and apply a suitable amount of the product on flange A.
3. Put together the two flanges, and thereby squeeze out surplus material. After curing, which can be accelerated considerably with heat, the application is finished.

Read the Wencon Instructions for use before application.

Wencon surface preparation

Choose the relevant surface preparation, depending on the nature of the job.

Surface preparation using dry blasting methods:

Application with Wencon products on a dry surface, at minimum 3°C above dew point.

1. Blast the machine part to SA 2,5 using sharp-edged blasting media, to a roughness of min. 75 microns.
2. Leave the part for sweating out salts in a warm place for at least 12 hours or heat it up to 30 - 40°C (86-104 °F) using gas torches.
3. Blast again to SA 2,5, prior to the application.
4. For parts containing a lot of water and salt, it may be necessary to repeat point 2 and 3, until the surface remains light grey, for at least 2 hours after blasting.
5. For optimal adhesion of Wencon products, always use Wencon Bio Cleaner or Wencon Cleaner prior to application. Follow one of below two methods:
 - 5.1 **Wencon Bio Cleaner**
Wet surface: Apply Wencon Bio Cleaner and let it work for 5-10 min. If necessary use a brush, to make sure the surface is clean. Rinse off with clean water and wipe off with an absorbing cloth.

Dry surface: Apply Wencon Bio Cleaner and let it work for 5-10 min. If necessary use a brush, to make sure the surface is clean. Rinse off with clean water and dry with an absorbing cloth or with compressed air for a completely dry surface. Hereafter any Wencon products can be applied.
 - 5.2 **Wencon Cleaner**
After surface preparation, apply Wencon Cleaner with a brush and allow the product to evaporate before applying other Wencon products. Wencon Cleaner is non-flammable. Use only in large or well ventilated rooms.

Surface preparation using wet/damp methods:

Water jet the entire surface with water and sand to a standard equal, to SA 2,5 as described above.

If the surface is left wet after surface preparation, is it important to dry out the surface or alternatively use a Wencon UW product.

Surface preparation for emergency/temporary applications:

If above surface preparation methods are not possible, it may be necessary to use one of below methods:

- Blasting
- Grinding
- Needle Gunning

In emergency / temporary applications it may be difficult to prepare the surface according to above methods. In any case, it is important to clean the surface to SA 2,5 and 75 microns roughness. If possible dry the surface before applying. If not possible, use Wencon UW products.

For further information on Wencon surface preparation, please contact our Area Sales Managers.

Fresh water generators - corrosion

APPLICATION DATA SHEET No. 116

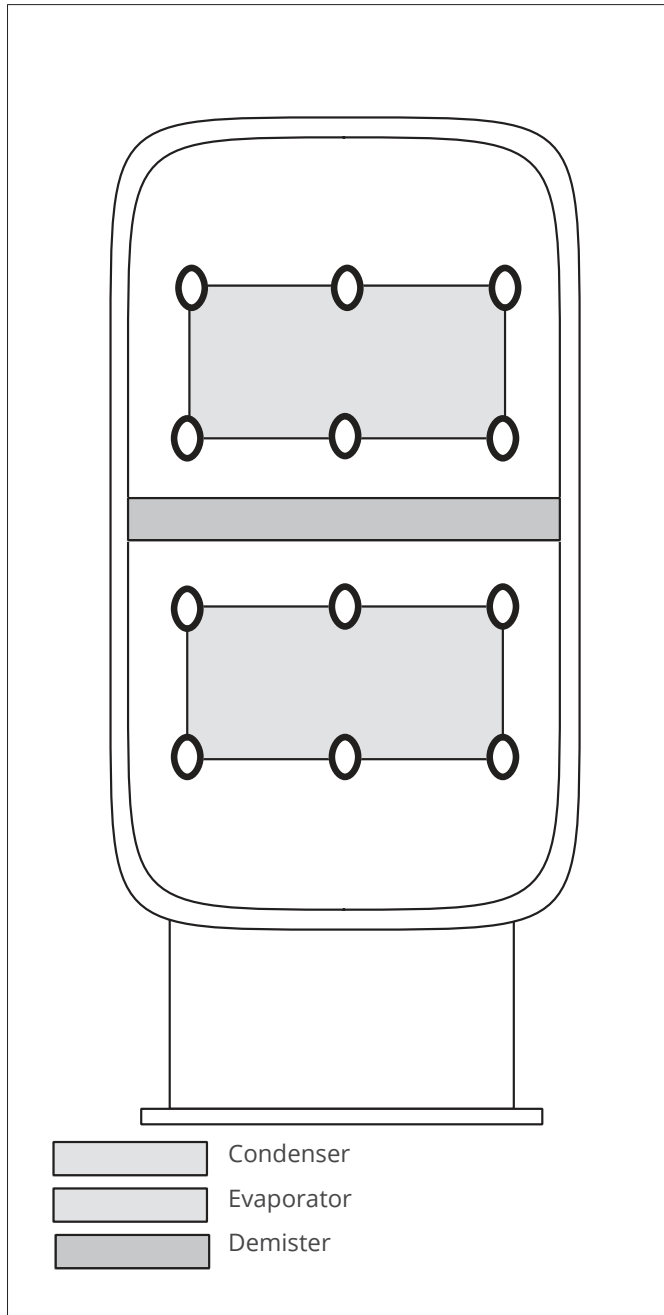

Fresh water generators made of coated mild steel, often suffer from salt water penetration, through the coating. The severe conditions inside the generator, might cause corrosion problems. It is ideal to have the coating repaired just after having noticed the damage.

Wencon Hi-Temp is suitable for this repair it will adhere to all common coatings like epoxy, polyester and even thermoplastics.

1. Tear off loose and damaged coating.
2. Grit blast or grind the affected area including an overlap of min. 5 cm (2 inch).
3. Clean the area acc. to Wencon surface preparation, next page.
4. Apply the Wencon Hi-Temp as described in the instructions for use. Apply two times, each approx. 300 μ (3/10 of a millimetre).
5. After curing, the surfaces should be cleaned using the Wencon Cleaner, and the application is finished.

Variations

If the generator body is badly corroded, use Wencon Cream or Wencon Rapid to rebuild the surface, before the Wencon Hi-Temp is applied.

Wencon Hi-Temp is not approved for use in combination with potable water, but in cases, where there is a demand or requirement for such, apply a layer of approved two-component paint as a top coat. Apply this final layer before the Wencon Hi-Temp has fully cured to assure the best possible adhesion.

Wencon surface preparation

Choose the relevant surface preparation, depending on the nature of the job.

Surface preparation using dry blasting methods:

Application with Wencon products on a dry surface, at minimum 3°C above dew point.

1. Blast the machine part to SA 2,5 using sharp-edged blasting media, to a roughness of min. 75 microns.
2. Leave the part for sweating out salts in a warm place for at least 12 hours or heat it up to 30 - 40°C (86-104 °F) using gas torches.
3. Blast again to SA 2,5, prior to the application.
4. For parts containing a lot of water and salt, it may be necessary to repeat point 2 and 3, until the surface remains light grey, for at least 2 hours after blasting.
5. For optimal adhesion of Wencon products, always use Wencon Bio Cleaner or Wencon Cleaner prior to application. Follow one of below two methods:
 - 5.1 **Wencon Bio Cleaner**
Wet surface: Apply Wencon Bio Cleaner and let it work for 5-10 min. If necessary use a brush, to make sure the surface is clean. Rinse off with clean water and wipe off with an absorbing cloth.

Dry surface: Apply Wencon Bio Cleaner and let it work for 5-10 min. If necessary use a brush, to make sure the surface is clean. Rinse off with clean water and dry with an absorbing cloth or with compressed air for a completely dry surface. Hereafter any Wencon products can be applied.
 - 5.2 **Wencon Cleaner**
 After surface preparation, apply Wencon Cleaner with a brush and allow the product to evaporate before applying other Wencon products. Wencon Cleaner is non-flammable. Use only in large or well ventilated rooms.

Surface preparation using wet/damp methods:

Water jet the entire surface with water and sand to a standard equal, to SA 2,5 as described above.

If the surface is left wet after surface preparation, is it important to dry out the surface or alternatively use a Wencon UW product.

Surface preparation for emergency/temporary applications:

If above surface preparation methods are not possible, it may be necessary to use one of below methods:

- Blasting
- Grinding
- Needle Gunning

In emergency / temporary applications it may be difficult to prepare the surface according to above methods. In any case, it is important to clean the surface to SA 2,5 and 75 microns roughness. If possible dry the surface before applying. If not possible, use Wencon UW products.

For further information on Wencon surface preparation, please contact our Area Sales Managers.

Hatch covers, sealing surface - corrosion

APPLICATION DATA SHEET No. 157

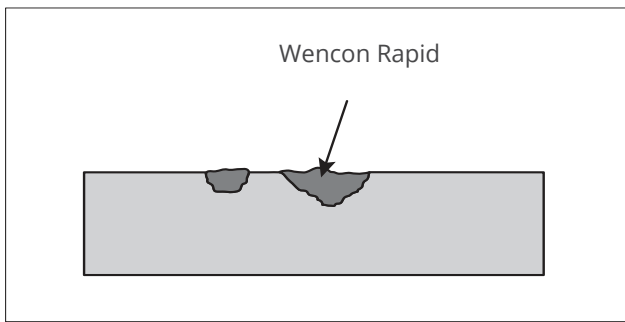
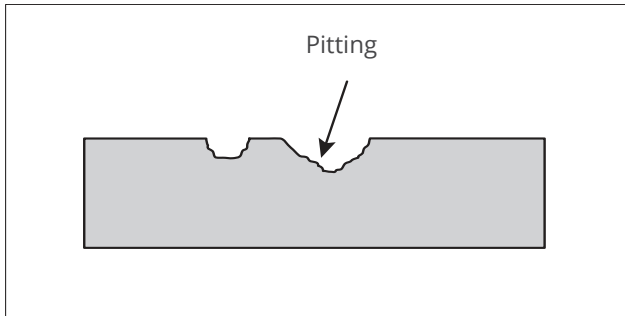

Hatch covers can be exposed to corrosion on the sealing surfaces.

This repair is easy to do and will last for a long time, especially on areas where there is no hard wear. Meaning, that on areas where you find a lot of wear, the repair will last shorter.

1. Prepare the corroded area acc. to Wencon surface preparation, next page.
2. Mix and apply Wencon Rapid, by using a spatula. Be sure that you fill up the entire pitted surface.
3. Let it cure.
4. After curing grind the area to an even surface.
5. Repeat 4-7 if more material is needed to fill up the pitted surface

It is possible to paint with own paint, on top of the Wencon Rapid after curing.

Wencon surface preparation

Choose the relevant surface preparation, depending on the nature of the job.

Surface preparation using dry blasting methods:

Application with Wencon products on a dry surface, at minimum 3°C above dew point.

1. Blast the machine part to SA 2,5 using sharp-edged blasting media, to a roughness of min. 75 microns.
2. Leave the part for sweating out salts in a warm place for at least 12 hours or heat it up to 30 - 40°C (86-104 °F) using gas torches.
3. Blast again to SA 2,5, prior to the application.
4. For parts containing a lot of water and salt, it may be necessary to repeat point 2 and 3, until the surface remains light grey, for at least 2 hours after blasting.
5. For optimal adhesion of Wencon products, always use Wencon Bio Cleaner or Wencon Cleaner prior to application. Follow one of below two methods:
 - 5.1 **Wencon Bio Cleaner**
Wet surface: Apply Wencon Bio Cleaner and let it work for 5-10 min. If necessary use a brush, to make sure the surface is clean. Rinse off with clean water and wipe off with an absorbing cloth.

Dry surface: Apply Wencon Bio Cleaner and let it work for 5-10 min. If necessary use a brush, to make sure the surface is clean. Rinse off with clean water and dry with an absorbing cloth or with compressed air for a completely dry surface. Hereafter any Wencon products can be applied.
 - 5.2 **Wencon Cleaner**
 After surface preparation, apply Wencon Cleaner with a brush and allow the product to evaporate before applying other Wencon products. Wencon Cleaner is non-flammable. Use only in large or well ventilated rooms.

Surface preparation using wet/damp methods:

Water jet the entire surface with water and sand to a standard equal, to SA 2,5 as described above.

If the surface is left wet after surface preparation, is it important to dry out the surface or alternatively use a Wencon UW product.

Surface preparation for emergency/temporary applications:

If above surface preparation methods are not possible, it may be necessary to use one of below methods:

- Blasting
- Grinding
- Needle Gunning

In emergency / temporary applications it may be difficult to prepare the surface according to above methods. In any case, it is important to clean the surface to SA 2,5 and 75 microns roughness. If possible dry the surface before applying. If not possible, use Wencon UW products.

For further information on Wencon surface preparation, please contact our Area Sales Managers.

Hot pipes - protection

APPLICATION DATA SHEET No. 115

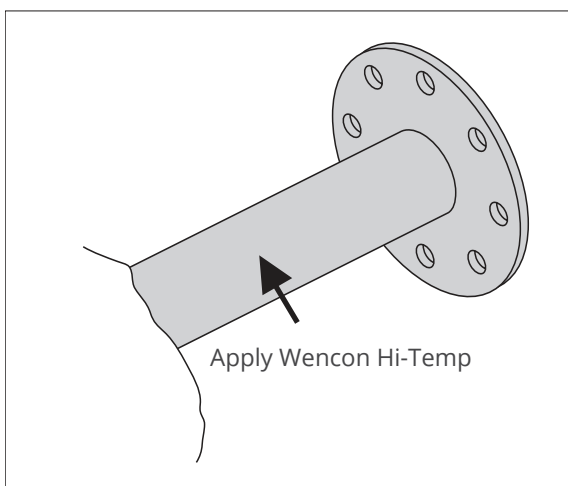
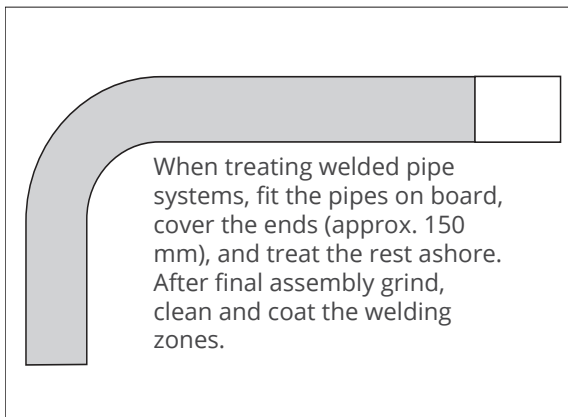
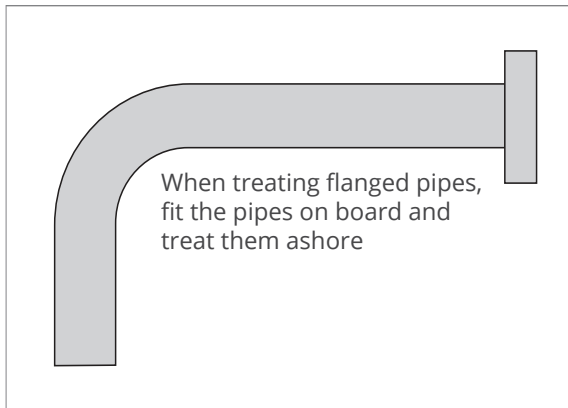

Hot-water, hot-oil or steam pipes will often be exposed to corrosion on the outer side, due to moisture or water in the insulation. Wencon can eliminate this breakdown with a coat of Wencon Hi-Temp.

Wencon Hi-Temp is a two-component fluid. It can be applied with a paint brush, and quite exceptionally it can be applied at temperatures of over 120°C (248°F).

The cured coating can withstand temperatures up to 160-200°C (320-424°F).

The coating is very simple to apply and can be made either before or after the pipes have been installed. The most common method, especially with new buildings, is that the pipes are first fitted on board, then removed ashore to be grit-blasted and coated. The only hindrance to making this operation on board is the lack of space.

One of the big advantages with the coating is that damages on the finished coating are easily repaired. The repair is limited to grinding the damaged area and applying a new coat.

Consumption of material. See chapter 1 in the Wencon Repair Manual.

For this application use radiator brushes with half the bristles cut off. This makes the brush well suited to the consistency of Wencon Hi-Temp.

1. Grit blast or grind a belt around the area to be repaired, and clean acc. to Wencon surface preparation, next page.
2. Apply the first layer of Wencon Hi-Temp yellow and let it semi-cure.
3. While the first layer is still tacky, apply the next layer of Wencon Hi-Temp Green.
4. The repair can be reinforced by using Wencon Reinforcement Tape wrapped tight in the wet Hi-Temp.
5. The finished layer thickness shall be 600-800 microns.

Wencon surface preparation

Choose the relevant surface preparation, depending on the nature of the job.

Surface preparation using dry blasting methods:

Application with Wencon products on a dry surface, at minimum 3°C above dew point.

1. Blast the machine part to SA 2,5 using sharp-edged blasting media, to a roughness of min. 75 microns.
2. Leave the part for sweating out salts in a warm place for at least 12 hours or heat it up to 30 - 40°C (86-104 °F) using gas torches.
3. Blast again to SA 2,5, prior to the application.
4. For parts containing a lot of water and salt, it may be necessary to repeat point 2 and 3, until the surface remains light grey, for at least 2 hours after blasting.
5. For optimal adhesion of Wencon products, always use Wencon Bio Cleaner or Wencon Cleaner prior to application. Follow one of below two methods:
 - 5.1 **Wencon Bio Cleaner**
Wet surface: Apply Wencon Bio Cleaner and let it work for 5-10 min. If necessary use a brush, to make sure the surface is clean. Rinse off with clean water and wipe off with an absorbing cloth.

Dry surface: Apply Wencon Bio Cleaner and let it work for 5-10 min. If necessary use a brush, to make sure the surface is clean. Rinse off with clean water and dry with an absorbing cloth or with compressed air for a completely dry surface. Hereafter any Wencon products can be applied.
 - 5.2 **Wencon Cleaner**
 After surface preparation, apply Wencon Cleaner with a brush and allow the product to evaporate before applying other Wencon products. Wencon Cleaner is non-flammable. Use only in large or well ventilated rooms.

Surface preparation using wet/damp methods:

Water jet the entire surface with water and sand to a standard equal, to SA 2,5 as described above.

If the surface is left wet after surface preparation, is it important to dry out the surface or alternatively use a Wencon UW product.

Surface preparation for emergency/temporary applications:

If above surface preparation methods are not possible, it may be necessary to use one of below methods:

- Blasting
- Grinding
- Needle Gunning

In emergency / temporary applications it may be difficult to prepare the surface according to above methods. In any case, it is important to clean the surface to SA 2,5 and 75 microns roughness. If possible dry the surface before applying. If not possible, use Wencon UW products.

For further information on Wencon surface preparation, please contact our Area Sales Managers.

Hydraulic rams - repair of scores

APPLICATION DATA SHEET No. 108

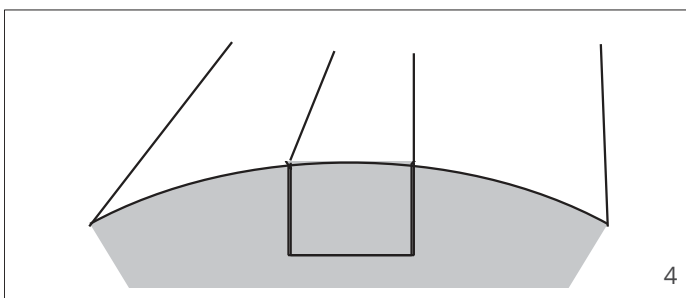
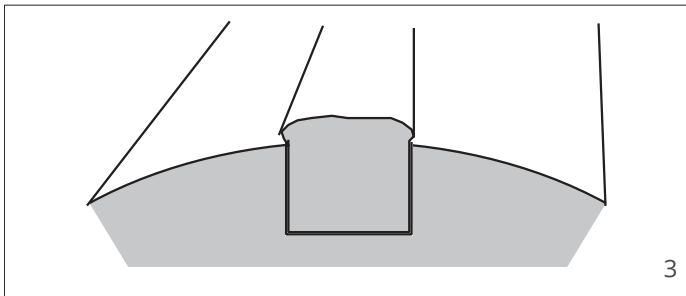
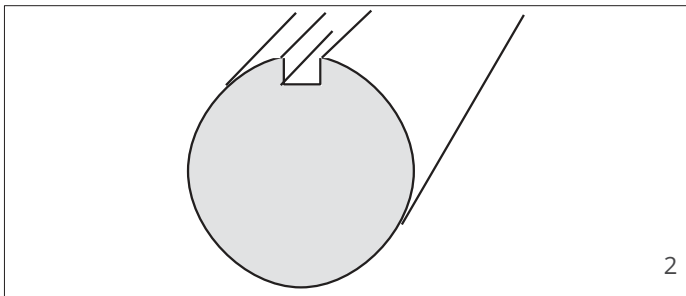
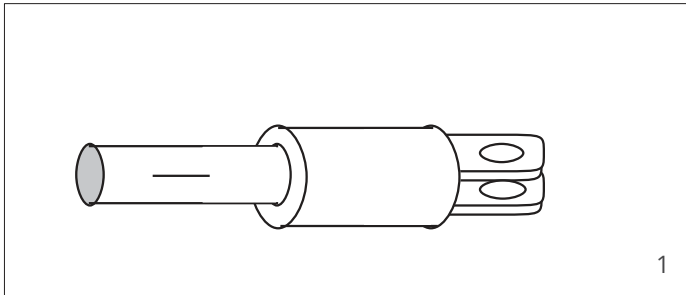

1. Clean the ram thoroughly acc. to Wencon surface preparation, next page.
2. Grind the score down with a wheel grinder, until the grinding score is more or less as wide as it is deep. Clean again thoroughly acc. to Wencon surface preparation next page. To aid cleaning, the ram can be heated, but only to approx. 40° C using hot air or oxygen/gas.

3. Mix and apply an adequate amount of Wencon Cream or Wencon Rapid (see ill.3). Allow the Wencon to semi cure and cut off the superfluous material with a sharp knife. Allow the Wencon to cure completely and then grind the surface clean with a fine grained emery cloth.

4. Grind the surface back into its original shape.

TIP: To make a grinding tool in the right shape, you can use Wencon Putty. Apply a thin layer of Wencon Release Agent to an undamaged area of the ram. Mix and apply some Wencon Putty on the ram where you have applied the Release Agent, and let it cure.

Now you have a tool in the exact dimensions to hold the emery cloth.

Variations:

The damage can be caused by a blow, or it can be a sore arising from contact with electric cables.

If the damage is a result of normal wear and tear and covers a large area, the repair described above is not suitable. In such cases we recommend machining after the Wencon compound has cured. In special cases, i.e. if the ram has a large diameter it can be an advantage to turn a mandrel.

Alternative products: Wencon Ceramic Cream

Wencon surface preparation

Choose the relevant surface preparation, depending on the nature of the job.

Surface preparation using dry blasting methods:

Application with Wencon products on a dry surface, at minimum 3°C above dew point.

1. Blast the machine part to SA 2,5 using sharp-edged blasting media, to a roughness of min. 75 microns.
2. Leave the part for sweating out salts in a warm place for at least 12 hours or heat it up to 30 - 40°C (86-104 °F) using gas torches.
3. Blast again to SA 2,5, prior to the application.
4. For parts containing a lot of water and salt, it may be necessary to repeat point 2 and 3, until the surface remains light grey, for at least 2 hours after blasting.
5. For optimal adhesion of Wencon products, always use Wencon Bio Cleaner or Wencon Cleaner prior to application. Follow one of below two methods:
 - 5.1 **Wencon Bio Cleaner**
Wet surface: Apply Wencon Bio Cleaner and let it work for 5-10 min. If necessary use a brush, to make sure the surface is clean. Rinse off with clean water and wipe off with an absorbing cloth.

Dry surface: Apply Wencon Bio Cleaner and let it work for 5-10 min. If necessary use a brush, to make sure the surface is clean. Rinse off with clean water and dry with an absorbing cloth or with compressed air for a completely dry surface. Hereafter any Wencon products can be applied.
 - 5.2 **Wencon Cleaner**
 After surface preparation, apply Wencon Cleaner with a brush and allow the product to evaporate before applying other Wencon products. Wencon Cleaner is non-flammable. Use only in large or well ventilated rooms.

Surface preparation using wet/damp methods:

Water jet the entire surface with water and sand to a standard equal, to SA 2,5 as described above.

If the surface is left wet after surface preparation, is it important to dry out the surface or alternatively use a Wencon UW product.

Surface preparation for emergency/temporary applications:

If above surface preparation methods are not possible, it may be necessary to use one of below methods:

- Blasting
- Grinding
- Needle Gunning

In emergency / temporary applications it may be difficult to prepare the surface according to above methods. In any case, it is important to clean the surface to SA 2,5 and 75 microns roughness. If possible dry the surface before applying. If not possible, use Wencon UW products.

For further information on Wencon surface preparation, please contact our Area Sales Managers.

Inert gas systems - lining

APPLICATION DATA SHEET No. 143

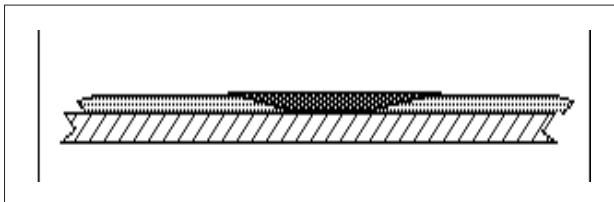
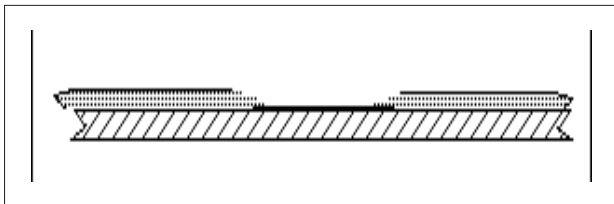
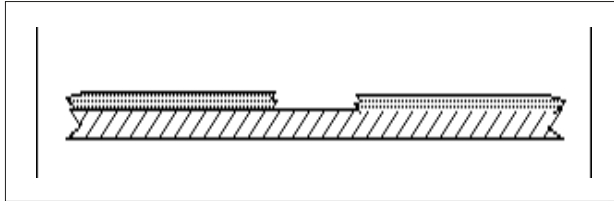

Lining of / or repair of existing lining of inert gas systems can be solved with Wencon Ceramic Coating.

In many cases, such lining consist of multilayer polyester systems, which are difficult and time consuming to repair. Furthermore, the polyester systems must be reinforced with glass flake material for longer penetration time.

Most of these systems require priming, which prolongs the process.

Wencon Ceramic Coating offers a fast and easy solution for this application and has an excellent adhesion to polyester and the epoxy systems.

1. Clean the area with steam or hot water removing acid and salts etc. and prepare the surface acc. to Wencon surface preparation, next page.
2. Mix and apply a suitable amount of Wencon Ceramic Coating. Let it cure for 1-2 hours, and finish the repair with a final coat of Wencon Ceramic Coating.

Wencon surface preparation

Choose the relevant surface preparation, depending on the nature of the job.

Surface preparation using dry blasting methods:

Application with Wencon products on a dry surface, at minimum 3°C above dew point.

1. Blast the machine part to SA 2,5 using sharp-edged blasting media, to a roughness of min. 75 microns.
2. Leave the part for sweating out salts in a warm place for at least 12 hours or heat it up to 30 - 40°C (86-104 °F) using gas torches.
3. Blast again to SA 2,5, prior to the application.
4. For parts containing a lot of water and salt, it may be necessary to repeat point 2 and 3, until the surface remains light grey, for at least 2 hours after blasting.
5. For optimal adhesion of Wencon products, always use Wencon Bio Cleaner or Wencon Cleaner prior to application. Follow one of below two methods:
 - 5.1 **Wencon Bio Cleaner**
Wet surface: Apply Wencon Bio Cleaner and let it work for 5-10 min. If necessary use a brush, to make sure the surface is clean. Rinse off with clean water and wipe off with an absorbing cloth.

Dry surface: Apply Wencon Bio Cleaner and let it work for 5-10 min. If necessary use a brush, to make sure the surface is clean. Rinse off with clean water and dry with an absorbing cloth or with compressed air for a completely dry surface. Hereafter any Wencon products can be applied.
 - 5.2 **Wencon Cleaner**
 After surface preparation, apply Wencon Cleaner with a brush and allow the product to evaporate before applying other Wencon products. Wencon Cleaner is non-flammable. Use only in large or well ventilated rooms.

Surface preparation using wet/damp methods:

Water jet the entire surface with water and sand to a standard equal, to SA 2,5 as described above.

If the surface is left wet after surface preparation, is it important to dry out the surface or alternatively use a Wencon UW product.

Surface preparation for emergency/temporary applications:

If above surface preparation methods are not possible, it may be necessary to use one of below methods:

- Blasting
- Grinding
- Needle Gunning

In emergency / temporary applications it may be difficult to prepare the surface according to above methods. In any case, it is important to clean the surface to SA 2,5 and 75 microns roughness. If possible dry the surface before applying. If not possible, use Wencon UW products.

For further information on Wencon surface preparation, please contact our Area Sales Managers.

Non-slip coating of rollers

APPLICATION DATA SHEET No. 125

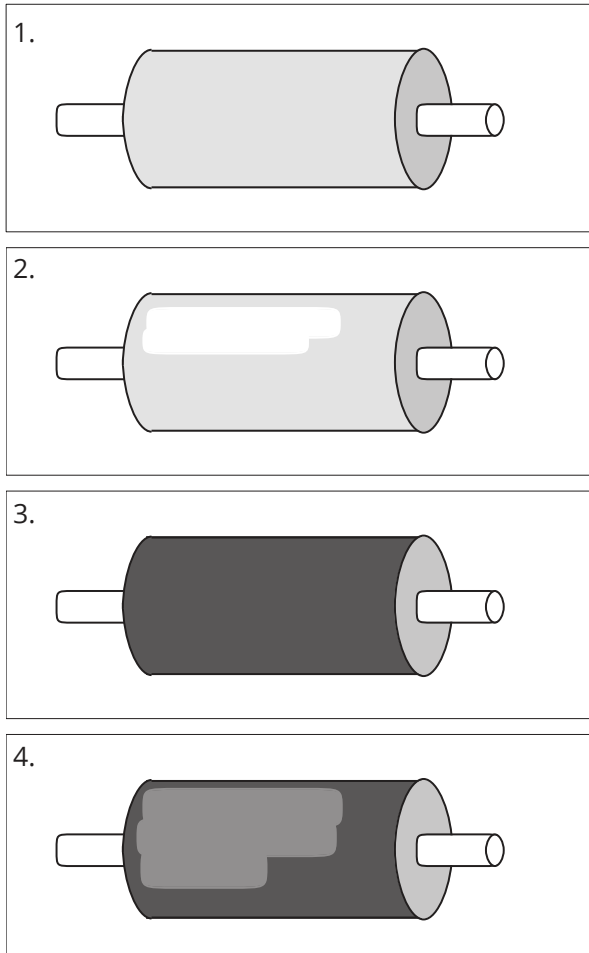

In many industrial units, there is an extensive use of rollers having a non-slip coating.

Repair or refurbishment of the non-slip coating requires most often dismantling and shipment to a workshop, which is costly and time consuming.

The benefits of using Wencon for this application, is that most applications can be done on site, sometimes even without dismantling.

Furthermore, the Wencon non-slip coating can be repaired on site as well.

1. Clean the surface acc. to Wencon surface preparation, next page. Grit blasting may be the best solution and grinding the only solution if the roller is not dismantled.
2. Apply a layer of Wencon Coating. The thickness applied shall correspond to the type of Wencon Aggregate used. Emphasize an even thickness.
3. Apply Wencon Aggregate no. 24 into the wet coating. If possible, rotate the roller during the application. Leave the roller for curing.

Curing time depends on temperature. The higher temperature, the shorter curing time. Curing time at 20°C (68°F) is 24 hours, at 60°C (140°F) 4-6 hours.

4. If the finished surfaces is more rough than expected, you can apply a thin coat of Wencon Coating on top of the Aggregate.

Wencon surface preparation

Choose the relevant surface preparation, depending on the nature of the job.

Surface preparation using dry blasting methods:

Application with Wencon products on a dry surface, at minimum 3°C above dew point.

1. Blast the machine part to SA 2,5 using sharp-edged blasting media, to a roughness of min. 75 microns.
2. Leave the part for sweating out salts in a warm place for at least 12 hours or heat it up to 30 - 40°C (86-104 °F) using gas torches.
3. Blast again to SA 2,5, prior to the application.
4. For parts containing a lot of water and salt, it may be necessary to repeat point 2 and 3, until the surface remains light grey, for at least 2 hours after blasting.
5. For optimal adhesion of Wencon products, always use Wencon Bio Cleaner or Wencon Cleaner prior to application. Follow one of below two methods:
 - 5.1 **Wencon Bio Cleaner**
Wet surface: Apply Wencon Bio Cleaner and let it work for 5-10 min. If necessary use a brush, to make sure the surface is clean. Rinse off with clean water and wipe off with an absorbing cloth.

Dry surface: Apply Wencon Bio Cleaner and let it work for 5-10 min. If necessary use a brush, to make sure the surface is clean. Rinse off with clean water and dry with an absorbing cloth or with compressed air for a completely dry surface. Hereafter any Wencon products can be applied.
 - 5.2 **Wencon Cleaner**
 After surface preparation, apply Wencon Cleaner with a brush and allow the product to evaporate before applying other Wencon products. Wencon Cleaner is non-flammable. Use only in large or well ventilated rooms.

Surface preparation using wet/damp methods:

Water jet the entire surface with water and sand to a standard equal, to SA 2,5 as described above.

If the surface is left wet after surface preparation, is it important to dry out the surface or alternatively use a Wencon UW product.

Surface preparation for emergency/temporary applications:

If above surface preparation methods are not possible, it may be necessary to use one of below methods:

- Blasting
- Grinding
- Needle Gunning

In emergency / temporary applications it may be difficult to prepare the surface according to above methods. In any case, it is important to clean the surface to SA 2,5 and 75 microns roughness. If possible dry the surface before applying. If not possible, use Wencon UW products.

For further information on Wencon surface preparation, please contact our Area Sales Managers.

Non-slip surface floors - stairs, drive rollers etc.

APPLICATION DATA SHEET No. 111

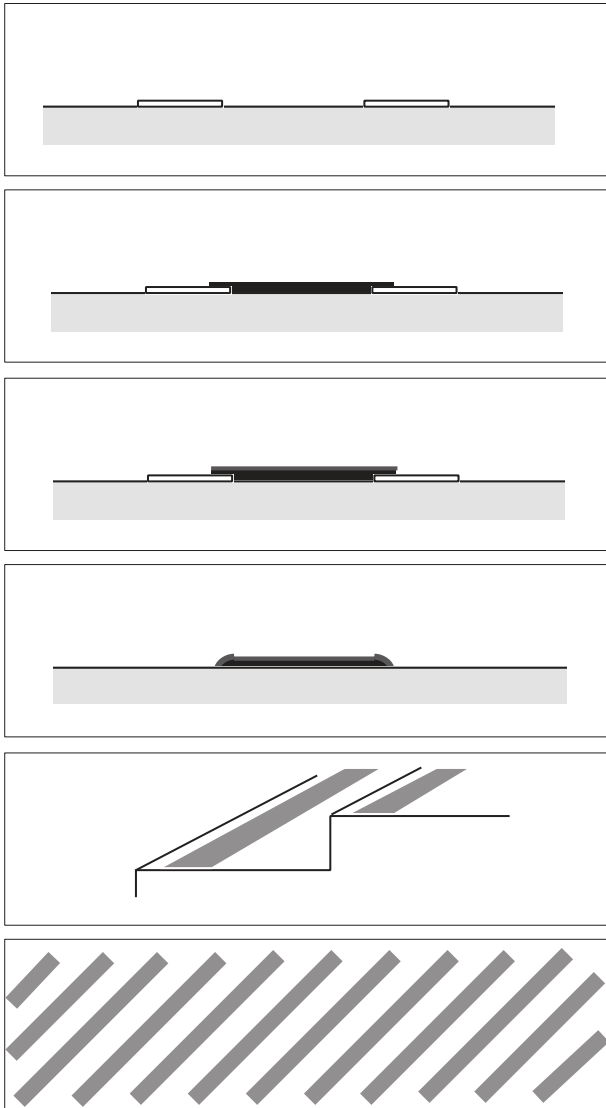

Wencon Coating and Aggregate are used to ensure non-slip surfaces in different situations. Most common applications are non-slip surfacing of floors, steps, stairs, passages etc. It is of equal interest to name conveyor belt drive rollers, forks on fork-lift trucks, rear loading ramps on lorries, and steps on cars or other transport machines. The system is very simple to use. Apply Wencon Coating to the surface to be treated, and sprinkle Wencon Aggregate on top.

1. Clean the surface acc. to Wencon surface preparation, next page. Required patterns can be formed by using a covering strip tape.
2. Mix and apply a thin coat of Wencon Coating.
3. Immediately after applying the coating, sprinkle a layer of Wencon Aggregate on the uncured surface.
4. Remove the tape before curing in order to obtain a nice round edge.
5. When non-slip treating stairs it is important that the strip is placed a few centimetres from the edge of each step, otherwise it is easy to scrape ones legs.
6. In many cases it is not necessary to cover the whole surface. Non-slip can be applied in strips, as shown. A strip width of 3 to 4 cm (1,2-1,6 inch), and intervals of 6 to 8 cm (2,4-3,2 inch) could be a starting point.

When non-slip surfacing drive rollers it is advised to treat the whole surface.

Wencon non-slip surfaces are resistant to oil, salt water, pure water and to most diluted acids.

Wencon surface preparation

Choose the relevant surface preparation, depending on the nature of the job.

Surface preparation using dry blasting methods:

Application with Wencon products on a dry surface, at minimum 3°C above dew point.

1. Blast the machine part to SA 2,5 using sharp-edged blasting media, to a roughness of min. 75 microns.
2. Leave the part for sweating out salts in a warm place for at least 12 hours or heat it up to 30 - 40°C (86-104 °F) using gas torches.
3. Blast again to SA 2,5, prior to the application.
4. For parts containing a lot of water and salt, it may be necessary to repeat point 2 and 3, until the surface remains light grey, for at least 2 hours after blasting.
5. For optimal adhesion of Wencon products, always use Wencon Bio Cleaner or Wencon Cleaner prior to application. Follow one of below two methods:
 - 5.1 **Wencon Bio Cleaner**
Wet surface: Apply Wencon Bio Cleaner and let it work for 5-10 min. If necessary use a brush, to make sure the surface is clean. Rinse off with clean water and wipe off with an absorbing cloth.

Dry surface: Apply Wencon Bio Cleaner and let it work for 5-10 min. If necessary use a brush, to make sure the surface is clean. Rinse off with clean water and dry with an absorbing cloth or with compressed air for a completely dry surface. Hereafter any Wencon products can be applied.
 - 5.2 **Wencon Cleaner**
After surface preparation, apply Wencon Cleaner with a brush and allow the product to evaporate before applying other Wencon products. Wencon Cleaner is non-flammable. Use only in large or well ventilated rooms.

Surface preparation using wet/damp methods:

Water jet the entire surface with water and sand to a standard equal, to SA 2,5 as described above.

If the surface is left wet after surface preparation, is it important to dry out the surface or alternatively use a Wencon UW product.

Surface preparation for emergency/temporary applications:

If above surface preparation methods are not possible, it may be necessary to use one of below methods:

- Blasting
- Grinding
- Needle Gunning

In emergency / temporary applications it may be difficult to prepare the surface according to above methods. In any case, it is important to clean the surface to SA 2,5 and 75 microns roughness. If possible dry the surface before applying. If not possible, use Wencon UW products.

For further information on Wencon surface preparation, please contact our Area Sales Managers.

Pipe ends and flanges - coating

APPLICATION DATA SHEET No. 106

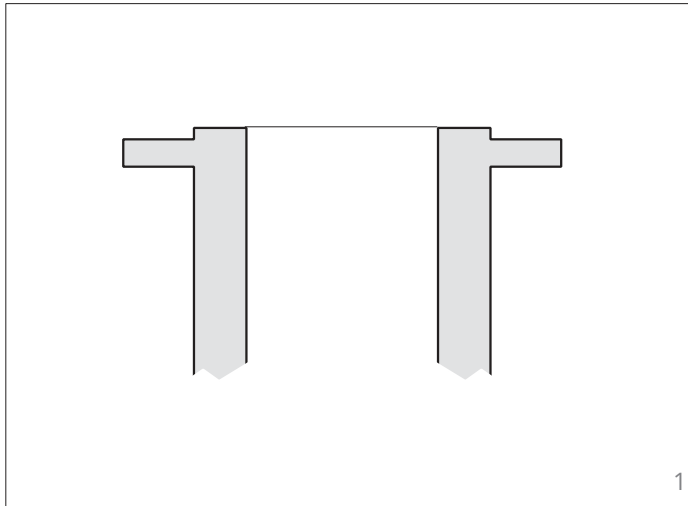

For extension of lifetime, the pipe ends can be coated internally. The coating must be done carefully, and according to below instructions.

1. Determine how far into the pipe, the coating has to be applied. Clean the surface acc. to Wencon surface preparation next page.
2. Before applying the Wencon Coating the innermost edge of the packing surface must be ground as shown in the diagram. It is important that the seal and the coating overlap, so as to avoid the untreated portion of the packing surface becoming wet. Apply the coating as shown in illustration 2. Please refer also to the directions for use of Wencon Coating.

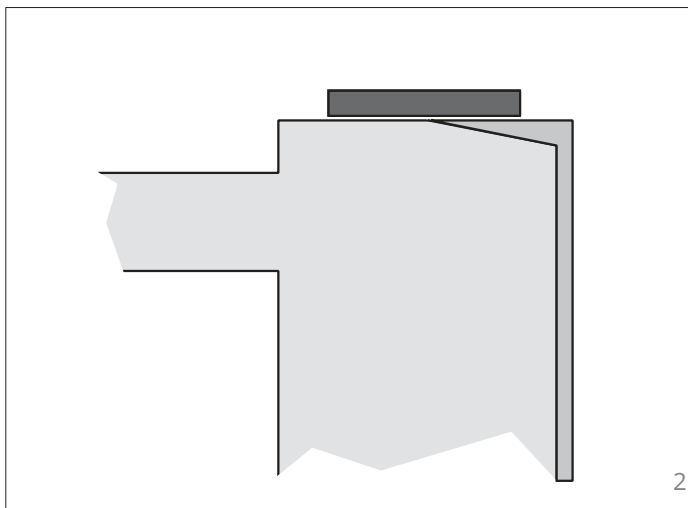

After curing, grind or turn to obtain a smooth packing surface.

This operation can be avoided if, before curing, a template/matrice is fitted tightly on to the flange. This template/matrice must be given a coat of Wencon Release Agent or be made of plastic.

When assembling the pipe, it is of great importance that the gasket does not press on the innermost edge of the flange (see diagram).

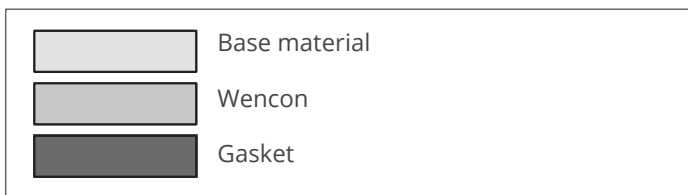

Alternative products:
 Wencon Ceramic Coating, Wencon UW Coating
 or Wencon Hi-Temp Coating

Wencon surface preparation

Choose the relevant surface preparation, depending on the nature of the job.

Surface preparation using dry blasting methods:

Application with Wencon products on a dry surface, at minimum 3°C above dew point.

1. Blast the machine part to SA 2,5 using sharp-edged blasting media, to a roughness of min. 75 microns.
2. Leave the part for sweating out salts in a warm place for at least 12 hours or heat it up to 30 - 40°C (86-104 °F) using gas torches.
3. Blast again to SA 2,5, prior to the application.
4. For parts containing a lot of water and salt, it may be necessary to repeat point 2 and 3, until the surface remains light grey, for at least 2 hours after blasting.
5. For optimal adhesion of Wencon products, always use Wencon Bio Cleaner or Wencon Cleaner prior to application. Follow one of below two methods:
 - 5.1 **Wencon Bio Cleaner**
Wet surface: Apply Wencon Bio Cleaner and let it work for 5-10 min. If necessary use a brush, to make sure the surface is clean. Rinse off with clean water and wipe off with an absorbing cloth.

Dry surface: Apply Wencon Bio Cleaner and let it work for 5-10 min. If necessary use a brush, to make sure the surface is clean. Rinse off with clean water and dry with an absorbing cloth or with compressed air for a completely dry surface. Hereafter any Wencon products can be applied.
 - 5.2 **Wencon Cleaner**
 After surface preparation, apply Wencon Cleaner with a brush and allow the product to evaporate before applying other Wencon products. Wencon Cleaner is non-flammable. Use only in large or well ventilated rooms.

Surface preparation using wet/damp methods:

Water jet the entire surface with water and sand to a standard equal, to SA 2,5 as described above.

If the surface is left wet after surface preparation, is it important to dry out the surface or alternatively use a Wencon UW product.

Surface preparation for emergency/temporary applications:

If above surface preparation methods are not possible, it may be necessary to use one of below methods:

- Blasting
- Grinding
- Needle Gunning

In emergency / temporary applications it may be difficult to prepare the surface according to above methods. In any case, it is important to clean the surface to SA 2,5 and 75 microns roughness. If possible dry the surface before applying. If not possible, use Wencon UW products.

For further information on Wencon surface preparation, please contact our Area Sales Managers.

Pipe repair - ballast pipes

APPLICATION DATA SHEET No. 151

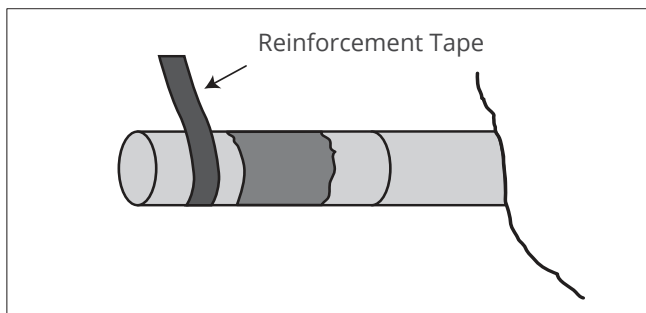
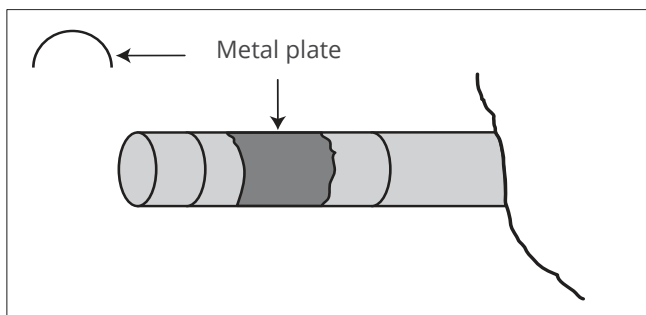
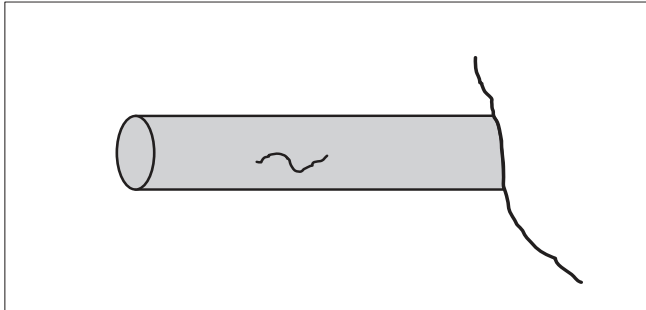

On all pipe repairs, consider temperature and pressure during operation. This will help you to choose the right Wencon product and the right application data sheet.

Guideline for the use of Wencon products:

For normal temperatures:

Use Wencon UW Cream or Rapid.

For top coating:

Use Wencon blue / white coating.

For high temperature pipes:

Use Wencon Hi-Temp or Ceramic products.

For wet surface (ballast pipes):

Use Wencon UW Cream and Wencon UW Coating as top coating.

Wencon Coating products are suitable for repairs on both steel and GRE (Epoxy) pipes.

1. Drain or de-pressurize the pipe. Clean and dry the repair area and determine the size of the leak.
2. With an angle grinder, a Rotating Blaster or coarse emery cloth, grind a belt around the pipe over an area of 10-15 cm (4-6 inch) wider than the leak. Clean the repair spot thoroughly acc. to Wencon surface preparation, next page.
3. If liquid is still coming out of the leak, mix and apply a suitable amount of Wencon Putty or Wencon UW Putty, directly into the crack, to stop the leak. Clean again acc. to Wencon Surface preparation.
4. Cover the leak with a metal plate bended in the same shape as the pipe using Wencon UW Cream as a glue. Blast /Grind and clean the metal plate on both sides.
5. Apply the first layer of Wencon UW Cream, using a brush or a spatula. (0,3-0,5 mm / 0.01-0.02 inch)
6. Again apply a layer of Wencon, and repeat until you have 3 layers of Wencon Reinforcement Tape and 4 layers of Wencon UW Cream.
7. For repairs that shall last for a longer period, we recommend to apply extra 2 layers of Wencon UW Cream using the same method.

Curing time can be speeded up by heating up using halogen lamps or similar.

To see the theoretical coverage rate please refer to product information in chapter 1, of the Wencon User Manual.

Wencon surface preparation

Choose the relevant surface preparation, depending on the nature of the job.

Surface preparation using dry blasting methods:

Application with Wencon products on a dry surface, at minimum 3°C above dew point.

1. Blast the machine part to SA 2,5 using sharp-edged blasting media, to a roughness of min. 75 microns.
2. Leave the part for sweating out salts in a warm place for at least 12 hours or heat it up to 30 - 40°C (86-104 °F) using gas torches.
3. Blast again to SA 2,5, prior to the application.
4. For parts containing a lot of water and salt, it may be necessary to repeat point 2 and 3, until the surface remains light grey, for at least 2 hours after blasting.
5. For optimal adhesion of Wencon products, always use Wencon Bio Cleaner or Wencon Cleaner prior to application. Follow one of below two methods:
 - 5.1 **Wencon Bio Cleaner**
Wet surface: Apply Wencon Bio Cleaner and let it work for 5-10 min. If necessary use a brush, to make sure the surface is clean. Rinse off with clean water and wipe off with an absorbing cloth.

Dry surface: Apply Wencon Bio Cleaner and let it work for 5-10 min. If necessary use a brush, to make sure the surface is clean. Rinse off with clean water and dry with an absorbing cloth or with compressed air for a completely dry surface. Hereafter any Wencon products can be applied.
 - 5.2 **Wencon Cleaner**
 After surface preparation, apply Wencon Cleaner with a brush and allow the product to evaporate before applying other Wencon products. Wencon Cleaner is non-flammable. Use only in large or well ventilated rooms.

Surface preparation using wet/damp methods:

Water jet the entire surface with water and sand to a standard equal, to SA 2,5 as described above.

If the surface is left wet after surface preparation, is it important to dry out the surface or alternatively use a Wencon UW product.

Surface preparation for emergency/temporary applications:

If above surface preparation methods are not possible, it may be necessary to use one of below methods:

- Blasting
- Grinding
- Needle Gunning

In emergency / temporary applications it may be difficult to prepare the surface according to above methods. In any case, it is important to clean the surface to SA 2,5 and 75 microns roughness. If possible dry the surface before applying. If not possible, use Wencon UW products.

For further information on Wencon surface preparation, please contact our Area Sales Managers.

Pipe repair - cable pipes

APPLICATION DATA SHEET No. 153

Wencon Pipe Tape is a very quick and easy way of repairing cable pipes. Wencon Pipe Tape is a fibre reinforcement tape impregnated with a polyurethane resin. It is activated by water, and shall be wrapped tight around the pipe as shown below.

Wencon Pipe Tape can be painted with all types of ship paint. In this application, it is acceptable to apply Wencon Pipe Tape without the use of Wencon Putty, due to the fact that the cable pipe is not operated with pressure.

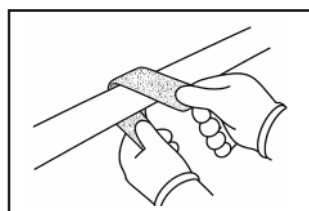

1. Scan the QR code or turn to next page to read about optimal surface preparation by dry blasting. If lower performance is accepted, surface preparation can be done by a rotating blaster or emery paper following a degrease with Wencon Cleaner.

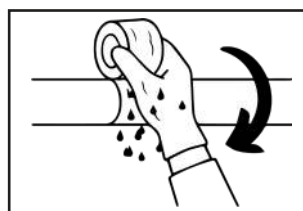

3. Wrap pipe tape firmly around pipe (min. 9 wraps with 50% overlap)



4. Dip gloves in water and smoothen pipe tape with hands in the direction of wrap until it sets

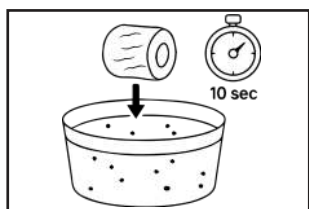

2. Soak pipe twape underwater for 10 seconds.

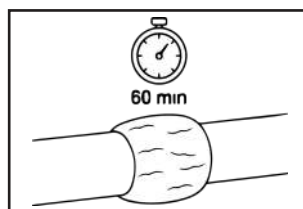

5. The pipe tape hardens after 10 min and fully cured after 60 min. (at 20 °C)

Normal pipe size		Outer pipe diameter	Pipe wrap length	9 x wraps	Wencon Pipe Tape Quantity (rolls)	Wencon Pipe Tape Quantity (rolls)	Wencon Pipe Tape Quantity (rolls)
NPS	DN	mm	mm	mm	5cm x 150cm	5cm x 350cm	10cm x 350cm
3/8	10	17,1	53	540	One		
1/2	15	21,3	66	658	One		
3/4	20	26,7	83	811	One		
1	25	33,4	104	1000	One		
1 1/4	32	42,2	132	1249	Two	One	
1 1/2	40	48,3	151	1422	Two	One	
2	50	60,3	189	1761	Two	One	
3	80	88,9	279	2570		One	
4	100	114,3	359	3288		Two	One
5	125	141,3	443	4051			Two
6	150	168,3	528	4815			Two
8	200	219,3	688	6257			Two

Wencon surface preparation

Choose the relevant surface preparation, depending on the nature of the job.

Surface preparation using dry blasting methods:

Application with Wencon products on a dry surface, at minimum 3°C above dew point.

1. Blast the machine part to SA 2,5 using sharp-edged blasting media, to a roughness of min. 75 microns.
2. Leave the part for sweating out salts in a warm place for at least 12 hours or heat it up to 30 - 40°C (86-104 °F) using gas torches.
3. Blast again to SA 2,5, prior to the application.
4. For parts containing a lot of water and salt, it may be necessary to repeat point 2 and 3, until the surface remains light grey, for at least 2 hours after blasting.
5. For optimal adhesion of Wencon products, always use Wencon Bio Cleaner or Wencon Cleaner prior to application. Follow one of below two methods:
 - 5.1 **Wencon Bio Cleaner**
Wet surface: Apply Wencon Bio Cleaner and let it work for 5-10 min. If necessary use a brush, to make sure the surface is clean. Rinse off with clean water and wipe off with an absorbing cloth.

Dry surface: Apply Wencon Bio Cleaner and let it work for 5-10 min. If necessary use a brush, to make sure the surface is clean. Rinse off with clean water and dry with an absorbing cloth or with compressed air for a completely dry surface. Hereafter any Wencon products can be applied.
 - 5.2 **Wencon Cleaner**
 After surface preparation, apply Wencon Cleaner with a brush and allow the product to evaporate before applying other Wencon products. Wencon Cleaner is non-flammable. Use only in large or well ventilated rooms.

Surface preparation using wet/damp methods:

Water jet the entire surface with water and sand to a standard equal, to SA 2,5 as described above.

If the surface is left wet after surface preparation, is it important to dry out the surface or alternatively use a Wencon UW product.

Surface preparation for emergency/temporary applications:

If above surface preparation methods are not possible, it may be necessary to use one of below methods:

- Blasting
- Grinding
- Needle Gunning

In emergency / temporary applications it may be difficult to prepare the surface according to above methods. In any case, it is important to clean the surface to SA 2,5 and 75 microns roughness. If possible dry the surface before applying. If not possible, use Wencon UW products.

For further information on Wencon surface preparation, please contact our Area Sales Managers.

Pipe repair - cargo pipe

APPLICATION DATA SHEET No. 150

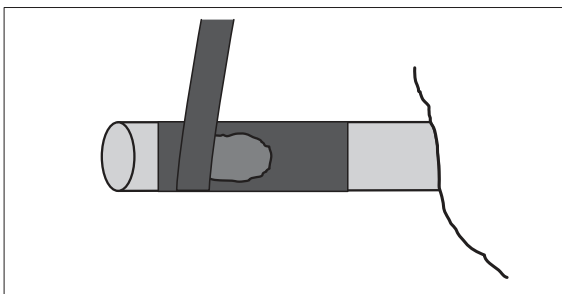
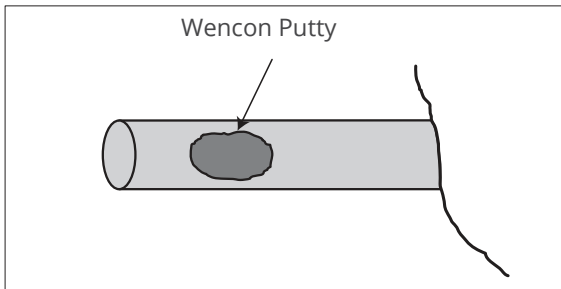
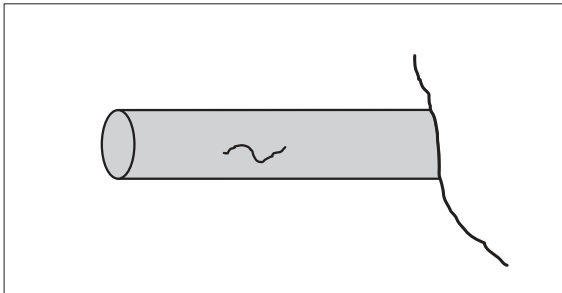

On all pipe repairs, you have to consider temperature and pressure during operation. This will help you to choose the right Wencon product and the right application data sheet.

Below find a guideline for the use of Wencon products:

For normal temperatures:
Use Wencon UW Cream or Rapid.

For top coating:
Use Wencon blue / white coating.

For high temperature pipes:
Use Wencon Hi-Temp or Ceramic products.

For wet surface (ballast pipes):
Use Wencon UW Cream and Wencon UW Coating as top coating.

1. Drain or de-pressurize the pipe. Clean and dry the repair area to determine the size of the leak.
2. With an angle grinder, a Rotating Blaster or coarse emery cloth, grind a belt around the pipe over an area of 10-15 cm (4-6 inch) wider than the leak. Clean the repair spot thoroughly acc. to Wencon surface preparation, next page.
3. If liquid is still coming out of the leak, mix and apply a suitable amount of Wencon Putty or Wencon UW putty, directly into the crack, to stop the leak. Clean again acc. to Wencon Surface preparation.
4. Mix an adequate amount of Wencon Cream or Wencon Rapid.
5. Apply the first layer of Wencon Cream or Wencon Rapid. (0,3-0,5 mm / 0.01-0.02 inch)
6. Wrap the Wencon Reinforcement Tape tightly around the pipe with 50% overlap. Make sure the Reinforcement Tape is fully impregnated with Wencon.
7. Again apply a layer of Wencon, and repeat until you have 3 layers of Wencon Reinforcement Tape and 2-3 layers of Wencon Cream or Rapid.
8. For repairs that shall last for a longer period, we recommend to apply extra 2 layers of Wencon Coating and Wencon Reinforcement Tape using same method.

Curing time can be speeded up by heating up - using Halogen lamps or like.

To see the theoretical coverage rate please refer to product information in chapter 1, of the Wencon User Manual.

Wencon surface preparation

Choose the relevant surface preparation, depending on the nature of the job.

Surface preparation using dry blasting methods:

Application with Wencon products on a dry surface, at minimum 3°C above dew point.

1. Blast the machine part to SA 2,5 using sharp-edged blasting media, to a roughness of min. 75 microns.
2. Leave the part for sweating out salts in a warm place for at least 12 hours or heat it up to 30 - 40°C (86-104 °F) using gas torches.
3. Blast again to SA 2,5, prior to the application.
4. For parts containing a lot of water and salt, it may be necessary to repeat point 2 and 3, until the surface remains light grey, for at least 2 hours after blasting.
5. For optimal adhesion of Wencon products, always use Wencon Bio Cleaner or Wencon Cleaner prior to application. Follow one of below two methods:
 - 5.1 **Wencon Bio Cleaner**
Wet surface: Apply Wencon Bio Cleaner and let it work for 5-10 min. If necessary use a brush, to make sure the surface is clean. Rinse off with clean water and wipe off with an absorbing cloth.

Dry surface: Apply Wencon Bio Cleaner and let it work for 5-10 min. If necessary use a brush, to make sure the surface is clean. Rinse off with clean water and dry with an absorbing cloth or with compressed air for a completely dry surface. Hereafter any Wencon products can be applied.
 - 5.2 **Wencon Cleaner**
 After surface preparation, apply Wencon Cleaner with a brush and allow the product to evaporate before applying other Wencon products. Wencon Cleaner is non-flammable. Use only in large or well ventilated rooms.

Surface preparation using wet/damp methods:

Water jet the entire surface with water and sand to a standard equal, to SA 2,5 as described above.

If the surface is left wet after surface preparation, is it important to dry out the surface or alternatively use a Wencon UW product.

Surface preparation for emergency/temporary applications:

If above surface preparation methods are not possible, it may be necessary to use one of below methods:

- Blasting
- Grinding
- Needle Gunning

In emergency / temporary applications it may be difficult to prepare the surface according to above methods. In any case, it is important to clean the surface to SA 2,5 and 75 microns roughness. If possible dry the surface before applying. If not possible, use Wencon UW products.

For further information on Wencon surface preparation, please contact our Area Sales Managers.

Pipe repair - emergency

APPLICATION DATA SHEET No. 128

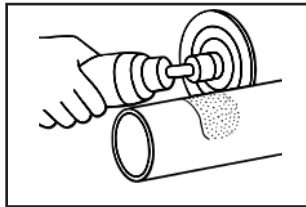

1. Scan the QR code to read about optimal surface preparation by dry blasting. If lower performance is accepted, surface preparation can be done by a rotating blaster following a degrease with Wencon Cleaner

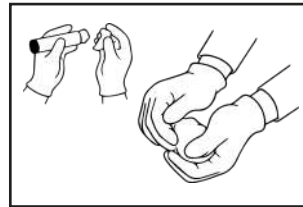

2. Tear off the needed amount of putty and knead it in your hands until even colour

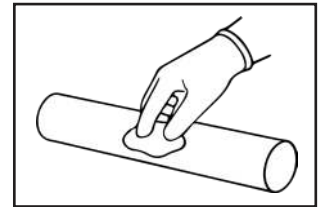

3. Place putty on the dry and clean surface and massage it into the damage using fingers

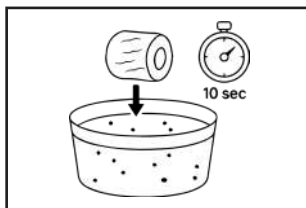

4. Soak pipe tape under water for 10 sec.

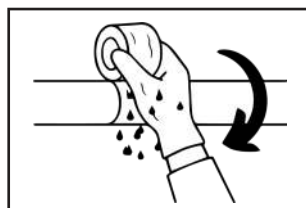

5. Wrap pipe tape firmly around pipe (min. 9 wraps with 50% overlap)



6. Dip gloves in water and smoothen pipe tape with hands in the direction of wrap until it sets

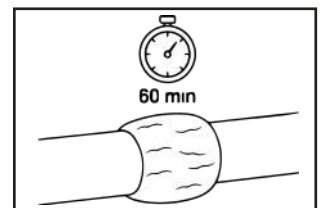

7. The pipe tape hardens after 10 min and fully cured after 60 min. (at 20 °C)

Technical Data

Pipe pressure with WENCON Putty: 50 Bar

Laboratory tests have shown much higher values, but the mentioned values will account for repairs done on site. Users are advised to make their own tests if in doubt.

Flexural strength: ASTM D709 111 N/mm sq.

Tensile strength: ASTM D638 172 N/mm sq.

Compression strength: ASTM D695 180 N/mm sq.

Adhesion at one-inch single overlap: 19 N/mm sq.

Dielectric strength: 16 KV/mm

Temperature Resistance

Continuous: 120°C (248°F)

Chemical Resistance

Water, salt water, oil, diluted acids and alkalis.

Handling Precautions

Read the instructions for use and the Safety Data Sheet.

Normal pipe size		Outer pipe diameter	Pipe wrap length	9 x wraps	Wencon Pipe Tape Quantity (rolls)	Wencon Pipe Tape Quantity (rolls)	Wencon Pipe Tape Quantity (rolls)
NPS	DN	mm	mm	mm	5cm x 150cm	5cm x 350cm	10cm x 350cm
3/8	10	17,1	53	540	One		
1/2	15	21,3	66	658	One		
3/4	20	26,7	83	811	One		
1	25	33,4	104	1000	One		
1 1/4	32	42,2	132	1249	Two	One	
1 1/2	40	48,3	151	1422	Two	One	
2	50	60,3	189	1761	Two	One	
3	80	88,9	279	2570		One	
4	100	114,3	359	3288		Two	One
5	125	141,3	443	4051			Two
6	150	168,3	528	4815			Two
8	200	219,3	688	6257			Two

Wencon surface preparation

Choose the relevant surface preparation, depending on the nature of the job.

Surface preparation using dry blasting methods:

Application with Wencon products on a dry surface, at minimum 3°C above dew point.

1. Blast the machine part to SA 2,5 using sharp-edged blasting media, to a roughness of min. 75 microns.
2. Leave the part for sweating out salts in a warm place for at least 12 hours or heat it up to 30 - 40°C (86-104 °F) using gas torches.
3. Blast again to SA 2,5, prior to the application.
4. For parts containing a lot of water and salt, it may be necessary to repeat point 2 and 3, until the surface remains light grey, for at least 2 hours after blasting.
5. For optimal adhesion of Wencon products, always use Wencon Bio Cleaner or Wencon Cleaner prior to application. Follow one of below two methods:
 - 5.1 **Wencon Bio Cleaner**
Wet surface: Apply Wencon Bio Cleaner and let it work for 5-10 min. If necessary use a brush, to make sure the surface is clean. Rinse off with clean water and wipe off with an absorbing cloth.

Dry surface: Apply Wencon Bio Cleaner and let it work for 5-10 min. If necessary use a brush, to make sure the surface is clean. Rinse off with clean water and dry with an absorbing cloth or with compressed air for a completely dry surface. Hereafter any Wencon products can be applied.
 - 5.2 **Wencon Cleaner**
 After surface preparation, apply Wencon Cleaner with a brush and allow the product to evaporate before applying other Wencon products. Wencon Cleaner is non-flammable. Use only in large or well ventilated rooms.

Surface preparation using wet/damp methods:

Water jet the entire surface with water and sand to a standard equal, to SA 2,5 as described above.

If the surface is left wet after surface preparation, is it important to dry out the surface or alternatively use a Wencon UW product.

Surface preparation for emergency/temporary applications:

If above surface preparation methods are not possible, it may be necessary to use one of below methods:

- Blasting
- Grinding
- Needle Gunning

In emergency / temporary applications it may be difficult to prepare the surface according to above methods. In any case, it is important to clean the surface to SA 2,5 and 75 microns roughness. If possible dry the surface before applying. If not possible, use Wencon UW products.

For further information on Wencon surface preparation, please contact our Area Sales Managers.

Pipe repair - heating coils

APPLICATION DATA SHEET No. 148



Heating coils often leak in the welding sleeve joints, due to the use of improper welding material. Heavily pitted pipe surfaces are often seen in the bottom area, and they are normally caused by the combination of bad steel, aggressive media, and high surface temperature.

Both types of leaks are easily repaired by use of Wencon Hi-Temp Coating and Reinforcement Tape.

Following procedure can be used:

1. Return pipes are dismantled and the pipes are drained for water, and blown through with compressed air, to ensure a dry surface.
2. Clean the area around the leak and carry out surface preparation acc. to Wencon surface preparation, next page.
3. Apply a thick layer (min. 500 microns) of Wencon Hi-Temp Coating with a brush.
4. Wrap Wencon Reinforcement Tape with a 50% overlap into the wet Coating, ensuring that the coating is penetrating the tape.
5. Apply a new layer of Wencon Hi-Temp, and a new layer of Reinforcement Tape, and follow the same procedure until you have at least 3 layers of Reinforcement Tape and 4 layers of Wencon Hi-Temp coating.
6. Let it cure for at least 8-10 hours before use.

Alternative products: [Wencon Ceramic Coating](#)

Wencon surface preparation

Choose the relevant surface preparation, depending on the nature of the job.

Surface preparation using dry blasting methods:

Application with Wencon products on a dry surface, at minimum 3°C above dew point.

1. Blast the machine part to SA 2,5 using sharp-edged blasting media, to a roughness of min. 75 microns.
2. Leave the part for sweating out salts in a warm place for at least 12 hours or heat it up to 30 - 40°C (86-104 °F) using gas torches.
3. Blast again to SA 2,5, prior to the application.
4. For parts containing a lot of water and salt, it may be necessary to repeat point 2 and 3, until the surface remains light grey, for at least 2 hours after blasting.
5. For optimal adhesion of Wencon products, always use Wencon Bio Cleaner or Wencon Cleaner prior to application. Follow one of below two methods:
 - 5.1 **Wencon Bio Cleaner**
Wet surface: Apply Wencon Bio Cleaner and let it work for 5-10 min. If necessary use a brush, to make sure the surface is clean. Rinse off with clean water and wipe off with an absorbing cloth.

Dry surface: Apply Wencon Bio Cleaner and let it work for 5-10 min. If necessary use a brush, to make sure the surface is clean. Rinse off with clean water and dry with an absorbing cloth or with compressed air for a completely dry surface. Hereafter any Wencon products can be applied.
 - 5.2 **Wencon Cleaner**
 After surface preparation, apply Wencon Cleaner with a brush and allow the product to evaporate before applying other Wencon products. Wencon Cleaner is non-flammable. Use only in large or well ventilated rooms.

Surface preparation using wet/damp methods:

Water jet the entire surface with water and sand to a standard equal, to SA 2,5 as described above.

If the surface is left wet after surface preparation, is it important to dry out the surface or alternatively use a Wencon UW product.

Surface preparation for emergency/temporary applications:

If above surface preparation methods are not possible, it may be necessary to use one of below methods:

- Blasting
- Grinding
- Needle Gunning

In emergency / temporary applications it may be difficult to prepare the surface according to above methods. In any case, it is important to clean the surface to SA 2,5 and 75 microns roughness. If possible dry the surface before applying. If not possible, use Wencon UW products.

For further information on Wencon surface preparation, please contact our Area Sales Managers.

Pipe repair - heating coils upper tank area

APPLICATION DATA SHEET No. 149

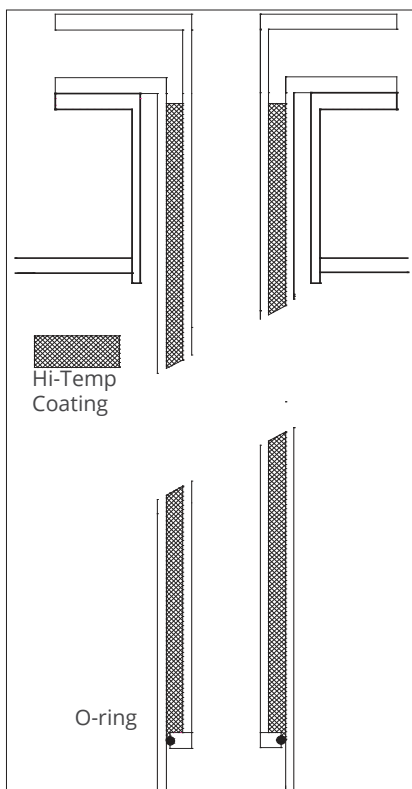
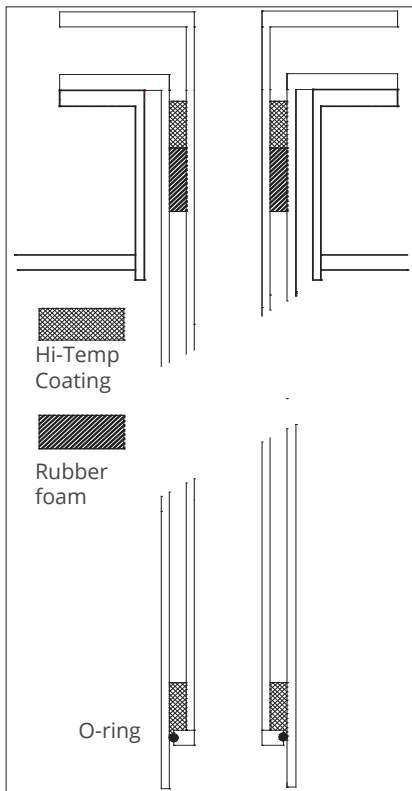

This area is normally very difficult to reach, as it demands the use of scaffolding from inside the tank.

Below find an alternative method of repairing this kind of damage from the deck-side.

Cast an insert pipe into the original pipe by injecting Wencon Hi Temp, which also helps to delay the bi-metallic corrosion. The insert pipe will naturally reduce the flow in the heating medium, so it has to be considered how much this will effect the heating capacity. An insert pipe is prepared, 2-3 cm (0,8-1,2 inch) smaller in outer diameter than the inner diameter of the original pipe, and in a length about 20 cm (8 inch) below the damaged area. In the bottom of the insert pipe there has to be a groove for an O-ring, to seal for the later injected Wencon Hi Temp Coating. The insert pipe can be made with a flange on the top. Make sure that the insert pipe will not fall down in the original pipe during the curing process. In case of larger holes in the original pipes, use method 1, if there are no leaks we recommend method 2.

Method 1

1. Slide in the insert pipe. If you choose a flange in the top on the insert pipe, leave approximately 10-15 cm (4-6 inch) free for injecting.
2. Mix Wencon Hi-Temp Coating and fill it in a standard cartridge for a "sealant-gun".
3. By means of a thin-walled steel- or plastic pipe mounted on the gun, a layer of 5 cm Coating is injected in the bottom area between the two pipes.
4. Remove the filling-pipe, and push in a layer of approximately 5 cm (2 inch) of rubber-foam to form a seal between the two pipes, and force it down 5-10 cm (2-4 inch) under the flange surface.
5. Fill the remaining gap between the two pipes with Wencon Hi-Temp. If the insert pipe has a flange, use Wencon Hi Temp coating as a sealing compound between the old and the new flange.
6. Let the coating cure for 8-10 hours. (The rubber-foam is used, to prevent coating leaking into the tank-area through holes in the damaged surface)

Method 2

1. Slide in the insert pipe into the original pipe.
2. Mix Wencon Hi-Temp Coating and fill it in a standard cartridge for a "sealant-gun".
3. By means of a thin-walled steel- or plastic pipe mounted on the gun, fill up the gap between the two pipes.
4. Let the coating cure for 8-10 hours.

Wencon surface preparation

Choose the relevant surface preparation, depending on the nature of the job.

Surface preparation using dry blasting methods:

Application with Wencon products on a dry surface, at minimum 3°C above dew point.

1. Blast the machine part to SA 2,5 using sharp-edged blasting media, to a roughness of min. 75 microns.
2. Leave the part for sweating out salts in a warm place for at least 12 hours or heat it up to 30 - 40°C (86-104 °F) using gas torches.
3. Blast again to SA 2,5, prior to the application.
4. For parts containing a lot of water and salt, it may be necessary to repeat point 2 and 3, until the surface remains light grey, for at least 2 hours after blasting.
5. For optimal adhesion of Wencon products, always use Wencon Bio Cleaner or Wencon Cleaner prior to application. Follow one of below two methods:
 - 5.1 **Wencon Bio Cleaner**
Wet surface: Apply Wencon Bio Cleaner and let it work for 5-10 min. If necessary use a brush, to make sure the surface is clean. Rinse off with clean water and wipe off with an absorbing cloth.

Dry surface: Apply Wencon Bio Cleaner and let it work for 5-10 min. If necessary use a brush, to make sure the surface is clean. Rinse off with clean water and dry with an absorbing cloth or with compressed air for a completely dry surface. Hereafter any Wencon products can be applied.
 - 5.2 **Wencon Cleaner**
After surface preparation, apply Wencon Cleaner with a brush and allow the product to evaporate before applying other Wencon products. Wencon Cleaner is non-flammable. Use only in large or well ventilated rooms.

Surface preparation using wet/damp methods:

Water jet the entire surface with water and sand to a standard equal, to SA 2,5 as described above.

If the surface is left wet after surface preparation, is it important to dry out the surface or alternatively use a Wencon UW product.

Surface preparation for emergency/temporary applications:

If above surface preparation methods are not possible, it may be necessary to use one of below methods:

- Blasting
- Grinding
- Needle Gunning

In emergency / temporary applications it may be difficult to prepare the surface according to above methods. In any case, it is important to clean the surface to SA 2,5 and 75 microns roughness. If possible dry the surface before applying. If not possible, use Wencon UW products.

For further information on Wencon surface preparation, please contact our Area Sales Managers.

Pipe repair - high pressure pipes

APPLICATION DATA SHEET No. 152

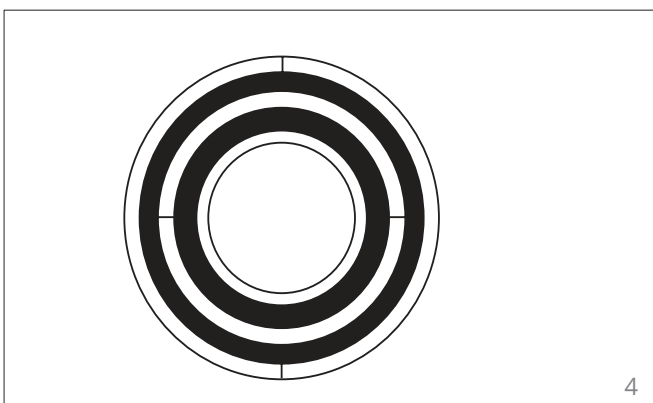
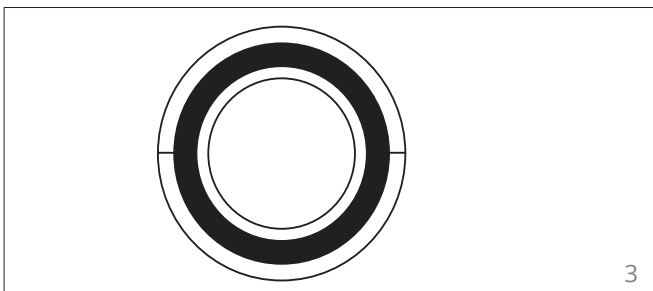
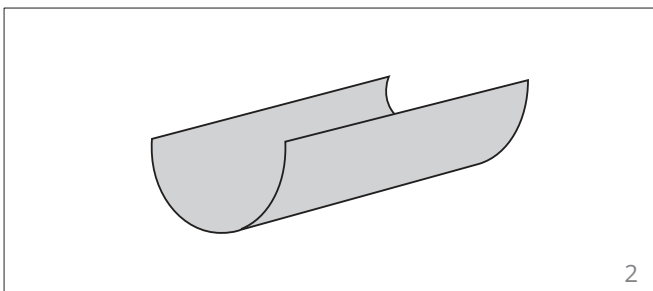
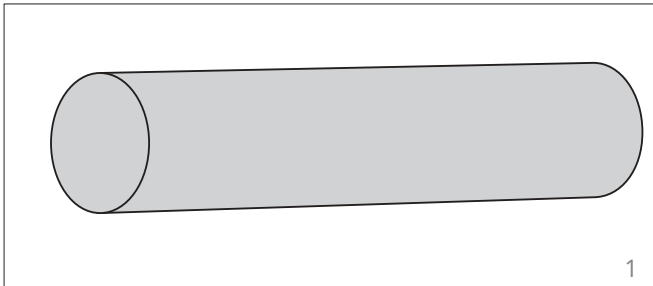

Repair of pipes with high pressure must always be considered carefully and acc. to national regulations.

The safest way of repairing a pipe is by using a high quality repair compound in combination with additional pieces of pipe.

1. Empty the pipe, if possible. If not, de-pressurize it. Grind and clean the repair area acc. to Wencon surface preparation, next page.
2. Prepare two pipe shells, as shown in ill. 2, allowing a gap of 3-10 mm (0,12-0,4 inch) between the external surface of the existing pipe and the internal surface of the pipe shells. The strength / thickness of the pipe shells shall be chosen according to pressure. Grind and clean the internal surfaces of the shells.
3. Mix and apply Wencon Cream or Rapid to the prepared areas and mount the shells as shown in ill. 3. Hold the shells in position by the use of pipe clamps or the like.
4. For further reinforcement, you can apply yet another set of pipe shells as shown in ill. 4.

Alternative products: [Wencon Ceramic Cream](#)

Wencon surface preparation

Choose the relevant surface preparation, depending on the nature of the job.

Surface preparation using dry blasting methods:

Application with Wencon products on a dry surface, at minimum 3°C above dew point.

1. Blast the machine part to SA 2,5 using sharp-edged blasting media, to a roughness of min. 75 microns.
2. Leave the part for sweating out salts in a warm place for at least 12 hours or heat it up to 30 - 40°C (86-104 °F) using gas torches.
3. Blast again to SA 2,5, prior to the application.
4. For parts containing a lot of water and salt, it may be necessary to repeat point 2 and 3, until the surface remains light grey, for at least 2 hours after blasting.
5. For optimal adhesion of Wencon products, always use Wencon Bio Cleaner or Wencon Cleaner prior to application. Follow one of below two methods:
 - 5.1 **Wencon Bio Cleaner**
Wet surface: Apply Wencon Bio Cleaner and let it work for 5-10 min. If necessary use a brush, to make sure the surface is clean. Rinse off with clean water and wipe off with an absorbing cloth.

Dry surface: Apply Wencon Bio Cleaner and let it work for 5-10 min. If necessary use a brush, to make sure the surface is clean. Rinse off with clean water and dry with an absorbing cloth or with compressed air for a completely dry surface. Hereafter any Wencon products can be applied.
 - 5.2 **Wencon Cleaner**
 After surface preparation, apply Wencon Cleaner with a brush and allow the product to evaporate before applying other Wencon products. Wencon Cleaner is non-flammable. Use only in large or well ventilated rooms.

Surface preparation using wet/damp methods:

Water jet the entire surface with water and sand to a standard equal, to SA 2,5 as described above.

If the surface is left wet after surface preparation, is it important to dry out the surface or alternatively use a Wencon UW product.

Surface preparation for emergency/temporary applications:

If above surface preparation methods are not possible, it may be necessary to use one of below methods:

- Blasting
- Grinding
- Needle Gunning

In emergency / temporary applications it may be difficult to prepare the surface according to above methods. In any case, it is important to clean the surface to SA 2,5 and 75 microns roughness. If possible dry the surface before applying. If not possible, use Wencon UW products.

For further information on Wencon surface preparation, please contact our Area Sales Managers.

Pipe repair - sea water pipe

APPLICATION DATA SHEET No. 102

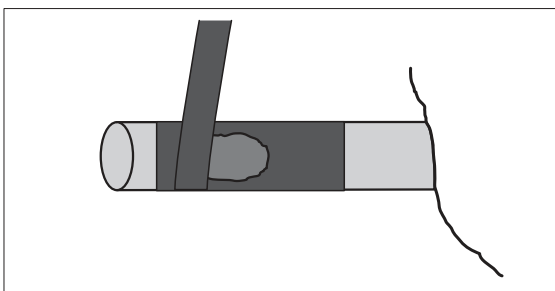
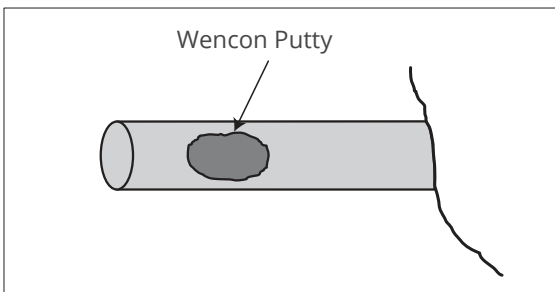
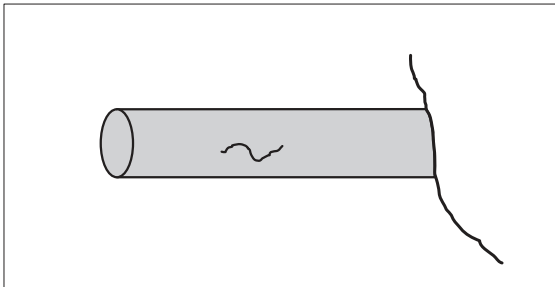

On all pipe repairs you have to consider temperature and pressure during operation. This will help you to choose the right Wencon product and the right application data sheet.

Below find a guideline for the use of Wencon products:

If the repair area is wet:
Use Wencon UW Cream .

For top coating:
Use Wencon UW Coating coating.

For high temperature pipes:
Use Wencon Hi-Temp or Ceramic products.

For dry surface :
Use Wencon Cream, Wencon Rapid and Wencon Coating as top coating.

1. Drain or de-pressurize the pipe. Clean and dry the repair area to determine the size of the leak.
2. With an angle grinder, a Rotating Blaster or coarse emery cloth, grind a belt around the pipe over an area of 10-15 cm (4-6 inch) wider than the leak. Clean the repair spot thoroughly acc. to Wencon surface preparation, next page.
3. If liquid is still coming out of the leak, mix and apply a suitable amount of Wencon UW putty, directly into the crack, to stop the leak. Clean again acc to Wencon Surface preparation.
4. Mix an adequate amount of Wencon UW Cream
5. Apply the first layer of Wencon UW Cream using a brush or spatula to a thickness 0,3-0,5 mm (0.01-0.02 inch)
6. Wrap the Wencon Reinforcement Tape tightly around the pipe with 50% overlap. Make sure the Reinforcement Tape is fully impregnated with Wencon.
7. Again apply a layer of Wencon UW Cream, and repeat until you have 3 layers of Wencon Reinforcement Tape and 2-3 layers of Wencon UW Cream.
8. For repairs that shall last for a longer period, we recommend to apply extra 2 layers of Wencon UW Coating and Wencon Reinforcement Tape using same method.

Curing time can be speeded up by heating up - using Halogen lamps or the like.

To see the theoretical coverage rate please refer to product information in chapter 1, of the Wencon User Manual.

Wencon surface preparation

Choose the relevant surface preparation, depending on the nature of the job.

Surface preparation using dry blasting methods:

Application with Wencon products on a dry surface, at minimum 3°C above dew point.

1. Blast the machine part to SA 2,5 using sharp-edged blasting media, to a roughness of min. 75 microns.
2. Leave the part for sweating out salts in a warm place for at least 12 hours or heat it up to 30 - 40°C (86-104 °F) using gas torches.
3. Blast again to SA 2,5, prior to the application.
4. For parts containing a lot of water and salt, it may be necessary to repeat point 2 and 3, until the surface remains light grey, for at least 2 hours after blasting.
5. For optimal adhesion of Wencon products, always use Wencon Bio Cleaner or Wencon Cleaner prior to application. Follow one of below two methods:
 - 5.1 **Wencon Bio Cleaner**
Wet surface: Apply Wencon Bio Cleaner and let it work for 5-10 min. If necessary use a brush, to make sure the surface is clean. Rinse off with clean water and wipe off with an absorbing cloth.

Dry surface: Apply Wencon Bio Cleaner and let it work for 5-10 min. If necessary use a brush, to make sure the surface is clean. Rinse off with clean water and dry with an absorbing cloth or with compressed air for a completely dry surface. Hereafter any Wencon products can be applied.
 - 5.2 **Wencon Cleaner**
 After surface preparation, apply Wencon Cleaner with a brush and allow the product to evaporate before applying other Wencon products. Wencon Cleaner is non-flammable. Use only in large or well ventilated rooms.

Surface preparation using wet/damp methods:

Water jet the entire surface with water and sand to a standard equal, to SA 2,5 as described above.

If the surface is left wet after surface preparation, is it important to dry out the surface or alternatively use a Wencon UW product.

Surface preparation for emergency/temporary applications:

If above surface preparation methods are not possible, it may be necessary to use one of below methods:

- Blasting
- Grinding
- Needle Gunning

In emergency / temporary applications it may be difficult to prepare the surface according to above methods. In any case, it is important to clean the surface to SA 2,5 and 75 microns roughness. If possible dry the surface before applying. If not possible, use Wencon UW products.

For further information on Wencon surface preparation, please contact our Area Sales Managers.

Pumps split-case, sealing seat - corrosion

APPLICATION DATA SHEET No. 109

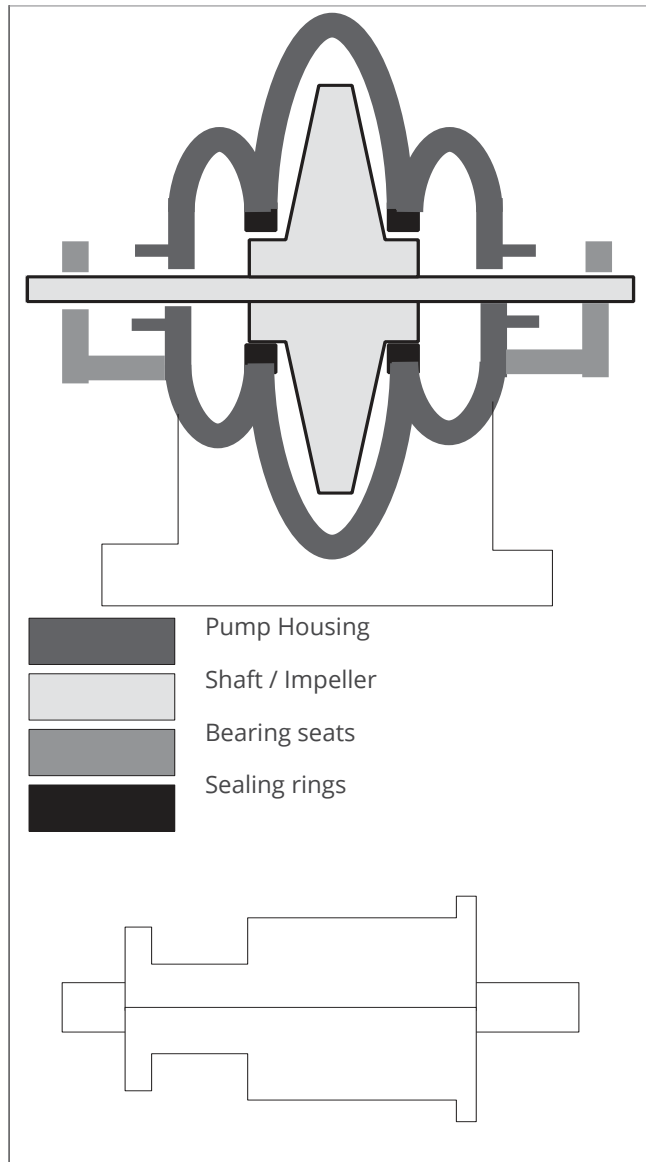

Corroded sealing seats and stuffing box housings are normally repaired by welding and line boring, but it is a long and costly process.

1. Disassemble the upper part of the pump housing and the impeller. Leave the bearings on the shaft.
2. Fit new sealing rings on the impeller placing a layer of foil or paper between the ring and the impeller. This ensures a central position of the ring. Apply a coat of Wencon Release Agent on the outside of the ring.
3. Clean the seating in the lowest part of the pump. Mix and apply Wencon Cream to the seating and the outer sides of the sealing rings. Assemble the impeller and mount the bearing seats. This moulds the ring seating to an exact fit to the rings.
4. After curing remove the impeller, grind the edges, treat the rings surfaces of the upper part with release agent, and mould the upper part of the housing in a corresponding manner. Remember to insert the gasket during this second moulding.
5. Stuffing box housings are cast in a similar way possibly at the same time. The casting template is made of two pipe shells (see diagram) which are tightened on the shaft. These must have the same shape as the stuffing box house is to have. Treat the shells with Wencon Release Agent before casting.

The advantage of method of repair, compared to traditional repairs or a replacement, is the time saved, the costs saved and the fact that the part is now life extended and protected against corrosion for up to 10 years.

The roller bearing seating can sometimes become damaged. These can be restored to it original dimensions using the same method as above.

Wencon surface preparation

Choose the relevant surface preparation, depending on the nature of the job.

Surface preparation using dry blasting methods:

Application with Wencon products on a dry surface, at minimum 3°C above dew point.

1. Blast the machine part to SA 2,5 using sharp-edged blasting media, to a roughness of min. 75 microns.
2. Leave the part for sweating out salts in a warm place for at least 12 hours or heat it up to 30 - 40°C (86-104 °F) using gas torches.
3. Blast again to SA 2,5, prior to the application.
4. For parts containing a lot of water and salt, it may be necessary to repeat point 2 and 3, until the surface remains light grey, for at least 2 hours after blasting.
5. For optimal adhesion of Wencon products, always use Wencon Bio Cleaner or Wencon Cleaner prior to application. Follow one of below two methods:
 - 5.1 **Wencon Bio Cleaner**
Wet surface: Apply Wencon Bio Cleaner and let it work for 5-10 min. If necessary use a brush, to make sure the surface is clean. Rinse off with clean water and wipe off with an absorbing cloth.

Dry surface: Apply Wencon Bio Cleaner and let it work for 5-10 min. If necessary use a brush, to make sure the surface is clean. Rinse off with clean water and dry with an absorbing cloth or with compressed air for a completely dry surface. Hereafter any Wencon products can be applied.
 - 5.2 **Wencon Cleaner**
 After surface preparation, apply Wencon Cleaner with a brush and allow the product to evaporate before applying other Wencon products. Wencon Cleaner is non-flammable. Use only in large or well ventilated rooms.

Surface preparation using wet/damp methods:

Water jet the entire surface with water and sand to a standard equal, to SA 2,5 as described above.

If the surface is left wet after surface preparation, is it important to dry out the surface or alternatively use a Wencon UW product.

Surface preparation for emergency/temporary applications:

If above surface preparation methods are not possible, it may be necessary to use one of below methods:

- Blasting
- Grinding
- Needle Gunning

In emergency / temporary applications it may be difficult to prepare the surface according to above methods. In any case, it is important to clean the surface to SA 2,5 and 75 microns roughness. If possible dry the surface before applying. If not possible, use Wencon UW products.

For further information on Wencon surface preparation, please contact our Area Sales Managers.

Pumps, casing cover - corrosion

APPLICATION DATA SHEET No. 123

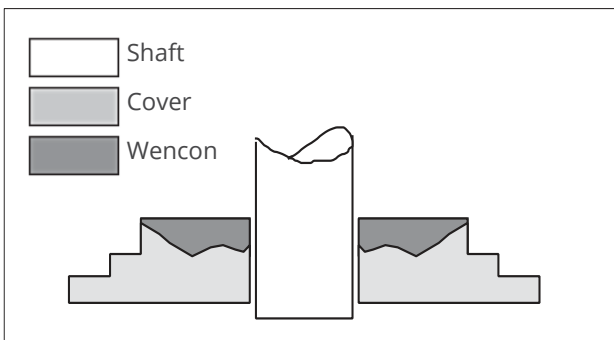
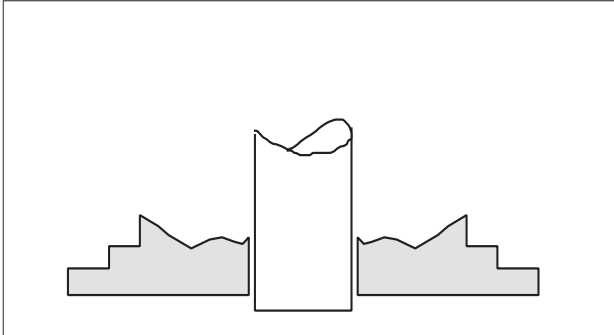

1. Before application be sure to perform a proper surface preparation acc. to Wencon surface preparation, next page.
2. Build up the surface to it's original shape and dimensions, using Wencon Cream or Rapid and let semi cure before next application.
3. Apply a layer of Wencon Coating over the entire internal surface covering both the repair area and to the edges of the cover/casing.
4. Finish with a second layer of Wencon Coating to protect against future corrosion.

Alternative repair methods:

1. Casting to fit: The casing cover can also be rebuilt using a casting method. Wencon Release Agent is applied on to the casting piece (bearing bush) and reassembling the impeller shaft to provide a centred position.

The space between the casting piece and the body may be filled up with Wencon Cream or Rapid and left to cure.

After curing, the impeller shaft and bearing is disassembled and machined for any residue.

2. Overbuilding and machining: The centre shaft area can be overbuild using Wencon Cream or Wencon rapid. After full cure it is possible to machine the part back to its original dimensions.

Wencon surface preparation

Choose the relevant surface preparation, depending on the nature of the job.

Surface preparation using dry blasting methods:

Application with Wencon products on a dry surface, at minimum 3°C above dew point.

1. Blast the machine part to SA 2,5 using sharp-edged blasting media, to a roughness of min. 75 microns.
2. Leave the part for sweating out salts in a warm place for at least 12 hours or heat it up to 30 - 40°C (86-104 °F) using gas torches.
3. Blast again to SA 2,5, prior to the application.
4. For parts containing a lot of water and salt, it may be necessary to repeat point 2 and 3, until the surface remains light grey, for at least 2 hours after blasting.
5. For optimal adhesion of Wencon products, always use Wencon Bio Cleaner or Wencon Cleaner prior to application. Follow one of below two methods:
 - 5.1 **Wencon Bio Cleaner**
Wet surface: Apply Wencon Bio Cleaner and let it work for 5-10 min. If necessary use a brush, to make sure the surface is clean. Rinse off with clean water and wipe off with an absorbing cloth.

Dry surface: Apply Wencon Bio Cleaner and let it work for 5-10 min. If necessary use a brush, to make sure the surface is clean. Rinse off with clean water and dry with an absorbing cloth or with compressed air for a completely dry surface. Hereafter any Wencon products can be applied.
 - 5.2 **Wencon Cleaner**
 After surface preparation, apply Wencon Cleaner with a brush and allow the product to evaporate before applying other Wencon products. Wencon Cleaner is non-flammable. Use only in large or well ventilated rooms.

Surface preparation using wet/damp methods:

Water jet the entire surface with water and sand to a standard equal, to SA 2,5 as described above.

If the surface is left wet after surface preparation, is it important to dry out the surface or alternatively use a Wencon UW product.

Surface preparation for emergency/temporary applications:

If above surface preparation methods are not possible, it may be necessary to use one of below methods:

- Blasting
- Grinding
- Needle Gunning

In emergency / temporary applications it may be difficult to prepare the surface according to above methods. In any case, it is important to clean the surface to SA 2,5 and 75 microns roughness. If possible dry the surface before applying. If not possible, use Wencon UW products.

For further information on Wencon surface preparation, please contact our Area Sales Managers.

Pumps, side cover - corrosion

APPLICATION DATA SHEET No. 124

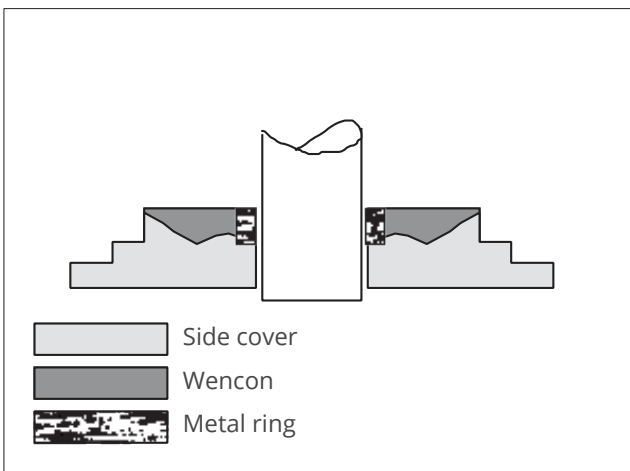
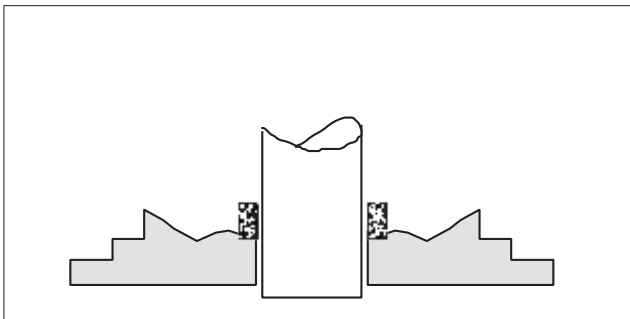
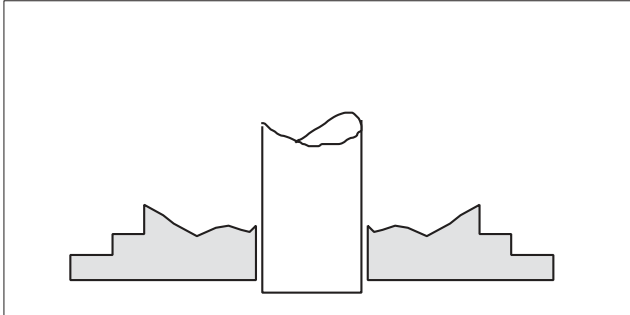

When a pump housing is suffering from deterioration, caused by a high degree of wear, from pumping sand and stones i.e. additional protection is recommended. For this repair we reinforce the area using a steel ring and Wencon Aggregate to increase the wear resistance.

In this case, the side cover are suffering from corrosion and wear in the inlet.

1. Clean the surface acc. to Wencon surface preparation, next page.
2. Create a steel ring having the same inner diameter as the inlet, and weld it into the cover. After the welding, fill the space behind the ring with Wencon Cream or Rapid, filled with Wencon Aggregate in weight ratio up to 1:1. The Aggregate will increase the wear resistance of the Wencon material.

When repairing other parts of those pumps, be aware, that it is not likely, that the Wencon material will stand the impact of big stones, so if the inner surface of the pump shall be made, the Wencon should only act as a support for wear segments.

See Application Data Sheet No. 119. Page 179.

Wencon surface preparation

Choose the relevant surface preparation, depending on the nature of the job.

Surface preparation using dry blasting methods:

Application with Wencon products on a dry surface, at minimum 3°C above dew point.

1. Blast the machine part to SA 2,5 using sharp-edged blasting media, to a roughness of min. 75 microns.
2. Leave the part for sweating out salts in a warm place for at least 12 hours or heat it up to 30 - 40°C (86-104 °F) using gas torches.
3. Blast again to SA 2,5, prior to the application.
4. For parts containing a lot of water and salt, it may be necessary to repeat point 2 and 3, until the surface remains light grey, for at least 2 hours after blasting.
5. For optimal adhesion of Wencon products, always use Wencon Bio Cleaner or Wencon Cleaner prior to application. Follow one of below two methods:
 - 5.1 **Wencon Bio Cleaner**
Wet surface: Apply Wencon Bio Cleaner and let it work for 5-10 min. If necessary use a brush, to make sure the surface is clean. Rinse off with clean water and wipe off with an absorbing cloth.

Dry surface: Apply Wencon Bio Cleaner and let it work for 5-10 min. If necessary use a brush, to make sure the surface is clean. Rinse off with clean water and dry with an absorbing cloth or with compressed air for a completely dry surface. Hereafter any Wencon products can be applied.
 - 5.2 **Wencon Cleaner**
 After surface preparation, apply Wencon Cleaner with a brush and allow the product to evaporate before applying other Wencon products. Wencon Cleaner is non-flammable. Use only in large or well ventilated rooms.

Surface preparation using wet/damp methods:

Water jet the entire surface with water and sand to a standard equal, to SA 2,5 as described above.

If the surface is left wet after surface preparation, is it important to dry out the surface or alternatively use a Wencon UW product.

Surface preparation for emergency/temporary applications:

If above surface preparation methods are not possible, it may be necessary to use one of below methods:

- Blasting
- Grinding
- Needle Gunning

In emergency / temporary applications it may be difficult to prepare the surface according to above methods. In any case, it is important to clean the surface to SA 2,5 and 75 microns roughness. If possible dry the surface before applying. If not possible, use Wencon UW products.

For further information on Wencon surface preparation, please contact our Area Sales Managers.

Rudder heel bushing - casting of seat

APPLICATION DATA SHEET No. 122

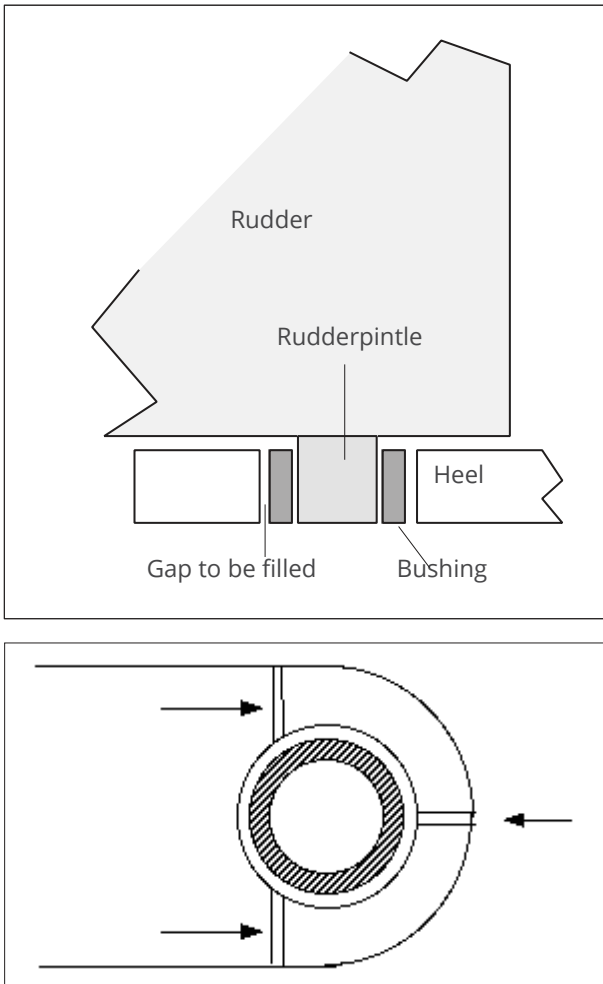

Oversized bearing houses for the rudder pintle bearing is a common problem. The deterioration of the seat is caused by bimetallic corrosion.

Before making the application, consult the local Wencon supplier and the classification society.

1. Grit blast the bearing housing to SA 2,5 and clean surface acc. to Wencon surface preparation, next page. During winter time, apply heat.
2. Machine the bearing leaving min. 3 millimetre (0,12 inch) space to be filled.
3. Drill 2 or 4 injection holes in the heel.
4. Mount the bearing and secure it either using the rudder pintle or by stick welding it to the heel.
5. Make sure, that the gap is filled in the bottom to prevent injected material to get out. Use Wencon Rapid.
6. The appropriate amount of Wencon Cream or Coating is mixed and injected using compressed air cartridges in a sealant gun. Mount self cutting screws in the holes when not using them anymore.
7. Curing. If the temperature is low, apply heat to the heel 30-40°C (70-93°F). Do not apply heat to the bearing. After approx. 8 hours at min. 20°C (68°F) the work can proceed.

The same repair technique can be used for creating a fit between the rudder pintle and its seat.

Wencon surface preparation

Choose the relevant surface preparation, depending on the nature of the job.

Surface preparation using dry blasting methods:

Application with Wencon products on a dry surface, at minimum 3°C above dew point.

1. Blast the machine part to SA 2,5 using sharp-edged blasting media, to a roughness of min. 75 microns.
2. Leave the part for sweating out salts in a warm place for at least 12 hours or heat it up to 30 - 40°C (86-104 °F) using gas torches.
3. Blast again to SA 2,5, prior to the application.
4. For parts containing a lot of water and salt, it may be necessary to repeat point 2 and 3, until the surface remains light grey, for at least 2 hours after blasting.
5. For optimal adhesion of Wencon products, always use Wencon Bio Cleaner or Wencon Cleaner prior to application. Follow one of below two methods:
 - 5.1 **Wencon Bio Cleaner**
Wet surface: Apply Wencon Bio Cleaner and let it work for 5-10 min. If necessary use a brush, to make sure the surface is clean. Rinse off with clean water and wipe off with an absorbing cloth.

Dry surface: Apply Wencon Bio Cleaner and let it work for 5-10 min. If necessary use a brush, to make sure the surface is clean. Rinse off with clean water and dry with an absorbing cloth or with compressed air for a completely dry surface. Hereafter any Wencon products can be applied.
 - 5.2 **Wencon Cleaner**
 After surface preparation, apply Wencon Cleaner with a brush and allow the product to evaporate before applying other Wencon products. Wencon Cleaner is non-flammable. Use only in large or well ventilated rooms.

Surface preparation using wet/damp methods:

Water jet the entire surface with water and sand to a standard equal, to SA 2,5 as described above.

If the surface is left wet after surface preparation, is it important to dry out the surface or alternatively use a Wencon UW product.

Surface preparation for emergency/temporary applications:

If above surface preparation methods are not possible, it may be necessary to use one of below methods:

- Blasting
- Grinding
- Needle Gunning

In emergency / temporary applications it may be difficult to prepare the surface according to above methods. In any case, it is important to clean the surface to SA 2,5 and 75 microns roughness. If possible dry the surface before applying. If not possible, use Wencon UW products.

For further information on Wencon surface preparation, please contact our Area Sales Managers.

Rudder heel pin, derrick - oversized

APPLICATION DATA SHEET No. 136

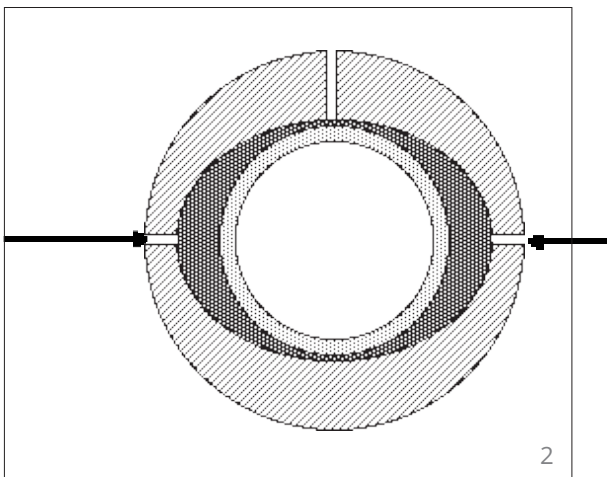
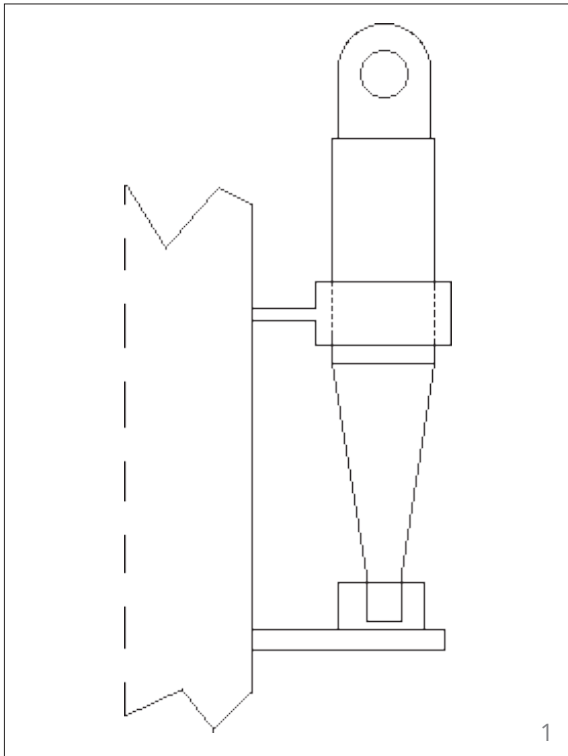

The traditional repair of oversized or oval needle bearings consists of welding and line boring. The method is very time consuming, especially because of the line boring.

Another method for this type of repair job is casting, which is described below:

1. Machine a thin bushing, and create room for it by means of grinding or using a blow torch.
2. The internal surface in the bushing seat should be prepared acc. to Wencon surface preparation, next page.
3. Apply a thin coat of Wencon Release Agent on the outside of the bushing. This prevents adhesion to the bushing and eases future replacement of the bushing.
4. Mix and apply a suitable amount of Wencon Cream or Rapid on to both the mating surfaces.
5. Put the bearing in position, and centre it by mounting the pin.

Alternative:

In some cases, the time factor makes you want to alter the method a bit. Mount the bushing without the Wencon material in between. Place it in position, and inject the Wencon through holes made as shown in fig. 2.

Wencon surface preparation

Choose the relevant surface preparation, depending on the nature of the job.

Surface preparation using dry blasting methods:

Application with Wencon products on a dry surface, at minimum 3°C above dew point.

1. Blast the machine part to SA 2,5 using sharp-edged blasting media, to a roughness of min. 75 microns.
2. Leave the part for sweating out salts in a warm place for at least 12 hours or heat it up to 30 - 40°C (86-104 °F) using gas torches.
3. Blast again to SA 2,5, prior to the application.
4. For parts containing a lot of water and salt, it may be necessary to repeat point 2 and 3, until the surface remains light grey, for at least 2 hours after blasting.
5. For optimal adhesion of Wencon products, always use Wencon Bio Cleaner or Wencon Cleaner prior to application. Follow one of below two methods:
 - 5.1 **Wencon Bio Cleaner**
Wet surface: Apply Wencon Bio Cleaner and let it work for 5-10 min. If necessary use a brush, to make sure the surface is clean. Rinse off with clean water and wipe off with an absorbing cloth.

Dry surface: Apply Wencon Bio Cleaner and let it work for 5-10 min. If necessary use a brush, to make sure the surface is clean. Rinse off with clean water and dry with an absorbing cloth or with compressed air for a completely dry surface. Hereafter any Wencon products can be applied.
 - 5.2 **Wencon Cleaner**
 After surface preparation, apply Wencon Cleaner with a brush and allow the product to evaporate before applying other Wencon products. Wencon Cleaner is non-flammable. Use only in large or well ventilated rooms.

Surface preparation using wet/damp methods:

Water jet the entire surface with water and sand to a standard equal, to SA 2,5 as described above.

If the surface is left wet after surface preparation, is it important to dry out the surface or alternatively use a Wencon UW product.

Surface preparation for emergency/temporary applications:

If above surface preparation methods are not possible, it may be necessary to use one of below methods:

- Blasting
- Grinding
- Needle Gunning

In emergency / temporary applications it may be difficult to prepare the surface according to above methods. In any case, it is important to clean the surface to SA 2,5 and 75 microns roughness. If possible dry the surface before applying. If not possible, use Wencon UW products.

For further information on Wencon surface preparation, please contact our Area Sales Managers.

Rudder tail shaft / stock - coating

APPLICATION DATA SHEET No. 139

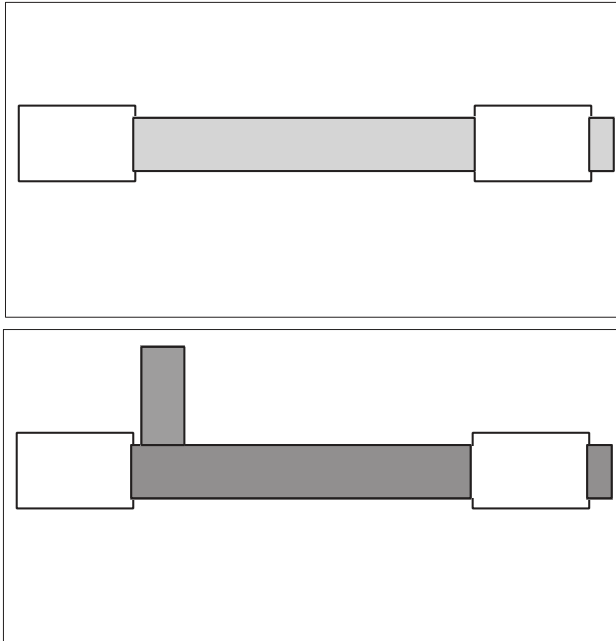

For new parts, leave out point 3. For corroded parts, start at point 1.

If the shaft has been exposed to salt water or oil, heat the shaft to 30-40° C (102-136°F), prior to grit blasting, in order to sweat out salt and oil.

1. Grind or grit blast the surface acc. to Wencon surface preparation, next page.
2. Mix and apply a suitable amount of Wencon Rapid to fill out the pits. Let it cure to a degree, where the surface is still a bit tacky.
3. Mix and apply the first layer of Wencon Coating, white in a thickness of 300 μ (0,3 mm) Use a flat angled brush having cut off half of the length of the bristles.
4. Wrap a layer of Wencon Reinforcement Tape tight around the shaft with an overlap of approx. 2 cm. Make sure, that some of the coating is pressed through the tape during the wrapping.
5. Leave it for curing for approx. one hour, and apply a layer of Wencon Coating, blue on the top to finish the application. Let it cure.

Handle the shaft carefully, in order not to damage the coating.

Wencon surface preparation

Choose the relevant surface preparation, depending on the nature of the job.

Surface preparation using dry blasting methods:

Application with Wencon products on a dry surface, at minimum 3°C above dew point.

1. Blast the machine part to SA 2,5 using sharp-edged blasting media, to a roughness of min. 75 microns.
2. Leave the part for sweating out salts in a warm place for at least 12 hours or heat it up to 30 - 40°C (86-104 °F) using gas torches.
3. Blast again to SA 2,5, prior to the application.
4. For parts containing a lot of water and salt, it may be necessary to repeat point 2 and 3, until the surface remains light grey, for at least 2 hours after blasting.
5. For optimal adhesion of Wencon products, always use Wencon Bio Cleaner or Wencon Cleaner prior to application. Follow one of below two methods:
 - 5.1 **Wencon Bio Cleaner**
Wet surface: Apply Wencon Bio Cleaner and let it work for 5-10 min. If necessary use a brush, to make sure the surface is clean. Rinse off with clean water and wipe off with an absorbing cloth.

Dry surface: Apply Wencon Bio Cleaner and let it work for 5-10 min. If necessary use a brush, to make sure the surface is clean. Rinse off with clean water and dry with an absorbing cloth or with compressed air for a completely dry surface. Hereafter any Wencon products can be applied.
 - 5.2 **Wencon Cleaner**
 After surface preparation, apply Wencon Cleaner with a brush and allow the product to evaporate before applying other Wencon products. Wencon Cleaner is non-flammable. Use only in large or well ventilated rooms.

Surface preparation using wet/damp methods:

Water jet the entire surface with water and sand to a standard equal, to SA 2,5 as described above.

If the surface is left wet after surface preparation, is it important to dry out the surface or alternatively use a Wencon UW product.

Surface preparation for emergency/temporary applications:

If above surface preparation methods are not possible, it may be necessary to use one of below methods:

- Blasting
- Grinding
- Needle Gunning

In emergency / temporary applications it may be difficult to prepare the surface according to above methods. In any case, it is important to clean the surface to SA 2,5 and 75 microns roughness. If possible dry the surface before applying. If not possible, use Wencon UW products.

For further information on Wencon surface preparation, please contact our Area Sales Managers.

Rudder stock / shaft - scored

APPLICATION DATA SHEET No. 121

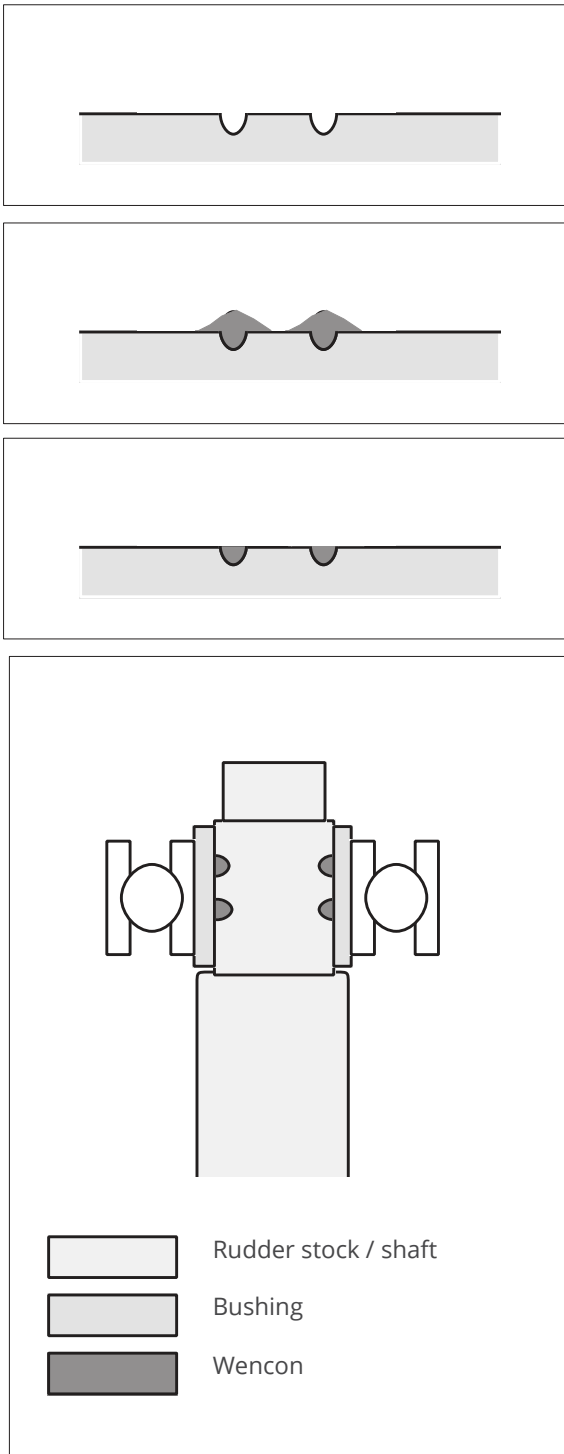

When removing a bushing, from a rudder stock or any other shaft, there might be created scores. In most cases this damage can be repaired with Wencon.

The obvious advantage is, that no heat is required for the application; unlike welding. The technique is very simple.

1. Grind the scores with a wheel grinder to bare metal (round shapes). Degrease and clean the area acc. to Wencon surface preparation, next page.
2. Mix and apply a suitable amount of Wencon Cream or Rapid as shown in the fig.
3. After a couple of hours, most of the excess material can be cut away using a knife. After full cure, the surface can be ground with emery cloth.

When remounting the bushing, do not heat above 100°C (212°F).

Wencon surface preparation

Choose the relevant surface preparation, depending on the nature of the job.

Surface preparation using dry blasting methods:

Application with Wencon products on a dry surface, at minimum 3°C above dew point.

1. Blast the machine part to SA 2,5 using sharp-edged blasting media, to a roughness of min. 75 microns.
2. Leave the part for sweating out salts in a warm place for at least 12 hours or heat it up to 30 - 40°C (86-104 °F) using gas torches.
3. Blast again to SA 2,5, prior to the application.
4. For parts containing a lot of water and salt, it may be necessary to repeat point 2 and 3, until the surface remains light grey, for at least 2 hours after blasting.
5. For optimal adhesion of Wencon products, always use Wencon Bio Cleaner or Wencon Cleaner prior to application. Follow one of below two methods:
 - 5.1 **Wencon Bio Cleaner**
Wet surface: Apply Wencon Bio Cleaner and let it work for 5-10 min. If necessary use a brush, to make sure the surface is clean. Rinse off with clean water and wipe off with an absorbing cloth.

Dry surface: Apply Wencon Bio Cleaner and let it work for 5-10 min. If necessary use a brush, to make sure the surface is clean. Rinse off with clean water and dry with an absorbing cloth or with compressed air for a completely dry surface. Hereafter any Wencon products can be applied.
 - 5.2 **Wencon Cleaner**
 After surface preparation, apply Wencon Cleaner with a brush and allow the product to evaporate before applying other Wencon products. Wencon Cleaner is non-flammable. Use only in large or well ventilated rooms.

Surface preparation using wet/damp methods:

Water jet the entire surface with water and sand to a standard equal, to SA 2,5 as described above.

If the surface is left wet after surface preparation, is it important to dry out the surface or alternatively use a Wencon UW product.

Surface preparation for emergency/temporary applications:

If above surface preparation methods are not possible, it may be necessary to use one of below methods:

- Blasting
- Grinding
- Needle Gunning

In emergency / temporary applications it may be difficult to prepare the surface according to above methods. In any case, it is important to clean the surface to SA 2,5 and 75 microns roughness. If possible dry the surface before applying. If not possible, use Wencon UW products.

For further information on Wencon surface preparation, please contact our Area Sales Managers.

Rudder stock bearing - casting of seat

APPLICATION DATA SHEET No. 110

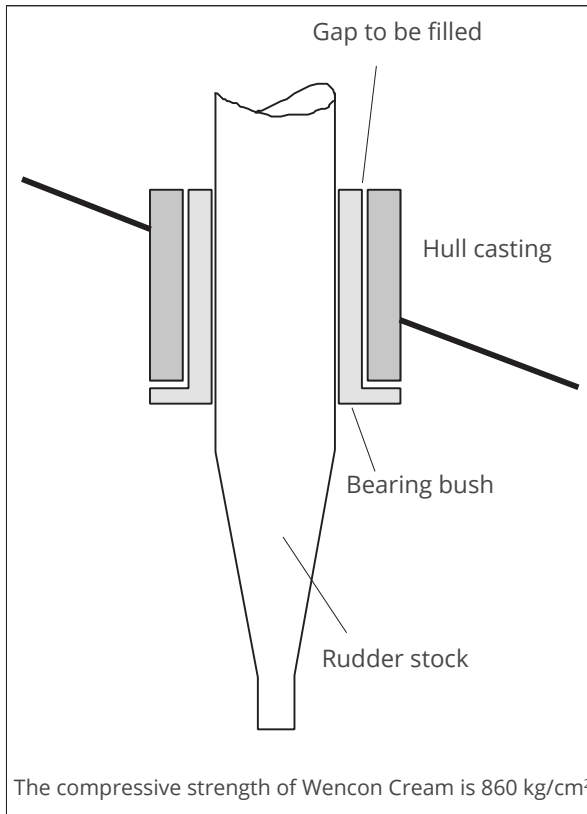

Before making this type of application, it is highly recommended to contact the local Wencon supplier and the classification society in charge.

Below is an example, how the majority of this type of application is done.

1. Grit blast the seat for the bearing to SA 2,5. During winter time apply heat.
2. Machine the bushing leaving min. 3 mm (0,12 inch) space to be filled. If the bushing is mounted as shown on the figure, apply Wencon Release Agent to the surface of the bushing. If no bolts are being used to secure the bushing, do not use release agent.
3. Drill injection holes in the hull casting. Four holes in the bottom approx. 30 mm (1,2 inch) from the bottom (spread around the circle), four holes in the middle, and two or four venting holes in the top.
4. Mount the bushing. The shown type can be mounted without use of the stock. Other types can be mounted by help of the rudder stock.
5. Make sure, that the gap is filled in the bottom to prevent injected material to get out. Use Wencon Rapid.
6. The appropriate amount of Wencon Cream or Coating is mixed and injected using compressed air cartridges in a sealant gun. Fill from the bottom and continue until material gets out of the venting holes in the top. Mount a self cutting screw in the holes when not using them anymore.
7. Curing. If the temperature is low, apply heat to the heel 30-40°C (86-104°F). Do not apply heat to the bearing. After approx. 8 hours at min. 20°C (68°F) the work can proceed.

Wencon surface preparation

Choose the relevant surface preparation, depending on the nature of the job.

Surface preparation using dry blasting methods:

Application with Wencon products on a dry surface, at minimum 3°C above dew point.

1. Blast the machine part to SA 2,5 using sharp-edged blasting media, to a roughness of min. 75 microns.
2. Leave the part for sweating out salts in a warm place for at least 12 hours or heat it up to 30 - 40°C (86-104 °F) using gas torches.
3. Blast again to SA 2,5, prior to the application.
4. For parts containing a lot of water and salt, it may be necessary to repeat point 2 and 3, until the surface remains light grey, for at least 2 hours after blasting.
5. For optimal adhesion of Wencon products, always use Wencon Bio Cleaner or Wencon Cleaner prior to application. Follow one of below two methods:
 - 5.1 **Wencon Bio Cleaner**
Wet surface: Apply Wencon Bio Cleaner and let it work for 5-10 min. If necessary use a brush, to make sure the surface is clean. Rinse off with clean water and wipe off with an absorbing cloth.

Dry surface: Apply Wencon Bio Cleaner and let it work for 5-10 min. If necessary use a brush, to make sure the surface is clean. Rinse off with clean water and dry with an absorbing cloth or with compressed air for a completely dry surface. Hereafter any Wencon products can be applied.
 - 5.2 **Wencon Cleaner**
After surface preparation, apply Wencon Cleaner with a brush and allow the product to evaporate before applying other Wencon products. Wencon Cleaner is non-flammable. Use only in large or well ventilated rooms.

Surface preparation using wet/damp methods:

Water jet the entire surface with water and sand to a standard equal, to SA 2,5 as described above.

If the surface is left wet after surface preparation, is it important to dry out the surface or alternatively use a Wencon UW product.

Surface preparation for emergency/temporary applications:

If above surface preparation methods are not possible, it may be necessary to use one of below methods:

- Blasting
- Grinding
- Needle Gunning

In emergency / temporary applications it may be difficult to prepare the surface according to above methods. In any case, it is important to clean the surface to SA 2,5 and 75 microns roughness. If possible dry the surface before applying. If not possible, use Wencon UW products.

For further information on Wencon surface preparation, please contact our Area Sales Managers.

Rudder stock cone application

APPLICATION DATA SHEET No. 113.1

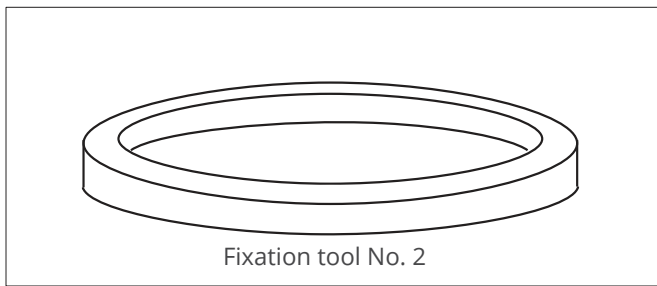

Problem:

Corrosion and/or bimetallic corrosion attack on inner surface of rudder blade cone and/or rudder stock cone (with key and key way).

Solution:

Building up a new surface in the inside of the rudder blade cone.

It is important that two auxiliary tools are prepared. The tools shall make it possible to centre the rudder stock and to keep the total length of the rudder stock/rudder blade.

Fixation tool No. 1

The height is given from the space under the bottom of the stock. The diameter of the upper part is given from the diameter of the bottom part of the stock. After fabrication the tool is stick welded to the rudder.

Fixation tool No. 2

The diameter of this ring is given from the diameter of the stock on the top side of the rudder. The ring shall be stick welded to the top of the rudder.

These tools will assure that the Wencon material, which is used for creating the new seat for the cone, will be cast in an even thickness round the rudder stock.

The rudder blade cone shall be cleaned acc. to Wencon surface preparation, next page.

It is hereafter ready to be taken back to the workshop and to be installed in an upright position.

If necessary, machine the rudder stock cone to remove corrosion. Place the rudder blade cone. Apply a thin layer of Wencon Release Agent on the rudder stock cone. Leave it for drying in at least five minutes and remove excess Wencon Release Agent leaving only a thin film.

The application

Mix a suitable amount of Wencon Cream and apply it to both the surface of the rudder blade cone and the rudder stock cone. Make sure that enough material is applied.

Continued on page 159

Wencon surface preparation

Choose the relevant surface preparation, depending on the nature of the job.

Surface preparation using dry blasting methods:

Application with Wencon products on a dry surface, at minimum 3°C above dew point.

1. Blast the machine part to SA 2,5 using sharp-edged blasting media, to a roughness of min. 75 microns.
2. Leave the part for sweating out salts in a warm place for at least 12 hours or heat it up to 30 - 40°C (86-104 °F) using gas torches.
3. Blast again to SA 2,5, prior to the application.
4. For parts containing a lot of water and salt, it may be necessary to repeat point 2 and 3, until the surface remains light grey, for at least 2 hours after blasting.
5. For optimal adhesion of Wencon products, always use Wencon Bio Cleaner or Wencon Cleaner prior to application. Follow one of below two methods:
 - 5.1 **Wencon Bio Cleaner**
Wet surface: Apply Wencon Bio Cleaner and let it work for 5-10 min. If necessary use a brush, to make sure the surface is clean. Rinse off with clean water and wipe off with an absorbing cloth.

Dry surface: Apply Wencon Bio Cleaner and let it work for 5-10 min. If necessary use a brush, to make sure the surface is clean. Rinse off with clean water and dry with an absorbing cloth or with compressed air for a completely dry surface. Hereafter any Wencon products can be applied.
 - 5.2 **Wencon Cleaner**
 After surface preparation, apply Wencon Cleaner with a brush and allow the product to evaporate before applying other Wencon products. Wencon Cleaner is non-flammable. Use only in large or well ventilated rooms.

Surface preparation using wet/damp methods:

Water jet the entire surface with water and sand to a standard equal, to SA 2,5 as described above.

If the surface is left wet after surface preparation, is it important to dry out the surface or alternatively use a Wencon UW product.

Surface preparation for emergency/temporary applications:

If above surface preparation methods are not possible, it may be necessary to use one of below methods:

- Blasting
- Grinding
- Needle Gunning

In emergency / temporary applications it may be difficult to prepare the surface according to above methods. In any case, it is important to clean the surface to SA 2,5 and 75 microns roughness. If possible dry the surface before applying. If not possible, use Wencon UW products.

For further information on Wencon surface preparation, please contact our Area Sales Managers.

Rudder stock cone application

APPLICATION DATA SHEET No. 113.2

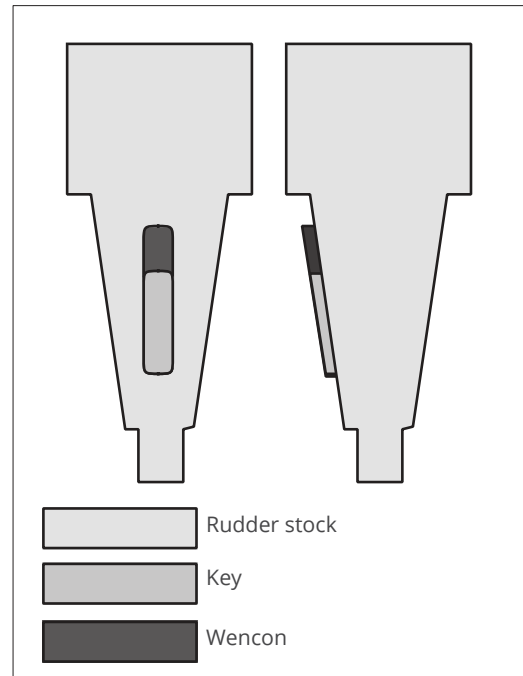
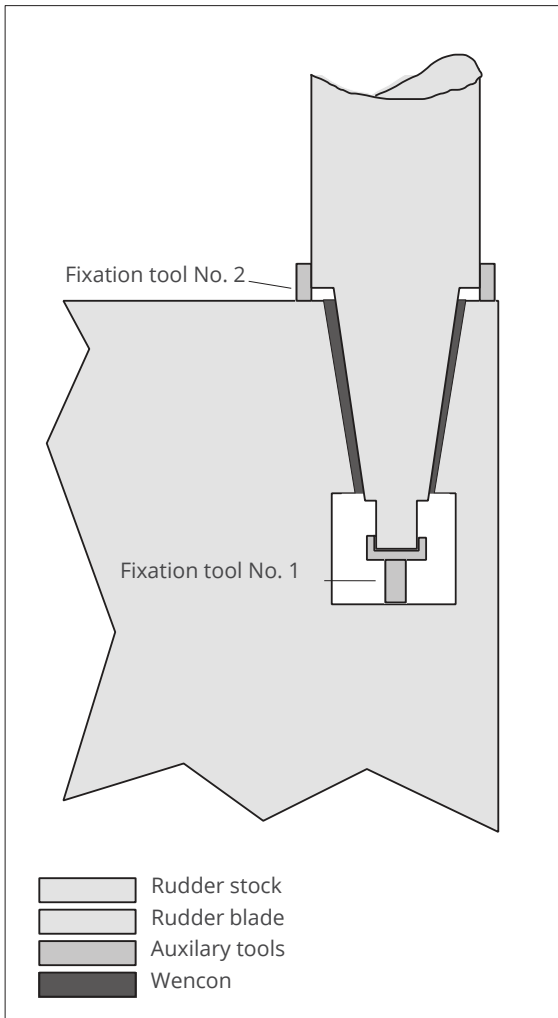

Continued from page 1

Be careful during the application to avoid air entrapment within the Wencon material.

After application of Wencon Cream, put the rudder stock into position, leaving excess Wencon material to be squeezed out from the gap.

To ensure the curing within a reasonable time (at winter), apply heat from e.g. two hot air blowers, blowing the hot air onto the rudder blade (not the rudder stock). Leave the application for curing approx. 8 hours.

Variations:

To ensure a proper cast in the key way, it is advisable to extend the key, at least when doing the application. A temporary extension of the key can be modelled using Wencon Putty as shown. Apply release agent on top, before casting.

Wencon surface preparation

Choose the relevant surface preparation, depending on the nature of the job.

Surface preparation using dry blasting methods:

Application with Wencon products on a dry surface, at minimum 3°C above dew point.

1. Blast the machine part to SA 2,5 using sharp-edged blasting media, to a roughness of min. 75 microns.
2. Leave the part for sweating out salts in a warm place for at least 12 hours or heat it up to 30 - 40°C (86-104 °F) using gas torches.
3. Blast again to SA 2,5, prior to the application.
4. For parts containing a lot of water and salt, it may be necessary to repeat point 2 and 3, until the surface remains light grey, for at least 2 hours after blasting.
5. For optimal adhesion of Wencon products, always use Wencon Bio Cleaner or Wencon Cleaner prior to application. Follow one of below two methods:
 - 5.1 **Wencon Bio Cleaner**
Wet surface: Apply Wencon Bio Cleaner and let it work for 5-10 min. If necessary use a brush, to make sure the surface is clean. Rinse off with clean water and wipe off with an absorbing cloth.

Dry surface: Apply Wencon Bio Cleaner and let it work for 5-10 min. If necessary use a brush, to make sure the surface is clean. Rinse off with clean water and dry with an absorbing cloth or with compressed air for a completely dry surface. Hereafter any Wencon products can be applied.
 - 5.2 **Wencon Cleaner**
 After surface preparation, apply Wencon Cleaner with a brush and allow the product to evaporate before applying other Wencon products. Wencon Cleaner is non-flammable. Use only in large or well ventilated rooms.

Surface preparation using wet/damp methods:

Water jet the entire surface with water and sand to a standard equal, to SA 2,5 as described above.

If the surface is left wet after surface preparation, is it important to dry out the surface or alternatively use a Wencon UW product.

Surface preparation for emergency/temporary applications:

If above surface preparation methods are not possible, it may be necessary to use one of below methods:

- Blasting
- Grinding
- Needle Gunning

In emergency / temporary applications it may be difficult to prepare the surface according to above methods. In any case, it is important to clean the surface to SA 2,5 and 75 microns roughness. If possible dry the surface before applying. If not possible, use Wencon UW products.

For further information on Wencon surface preparation, please contact our Area Sales Managers.

Sea water filters housing - corrosion

Mudbox corrosion

APPLICATION DATA SHEET No. 114

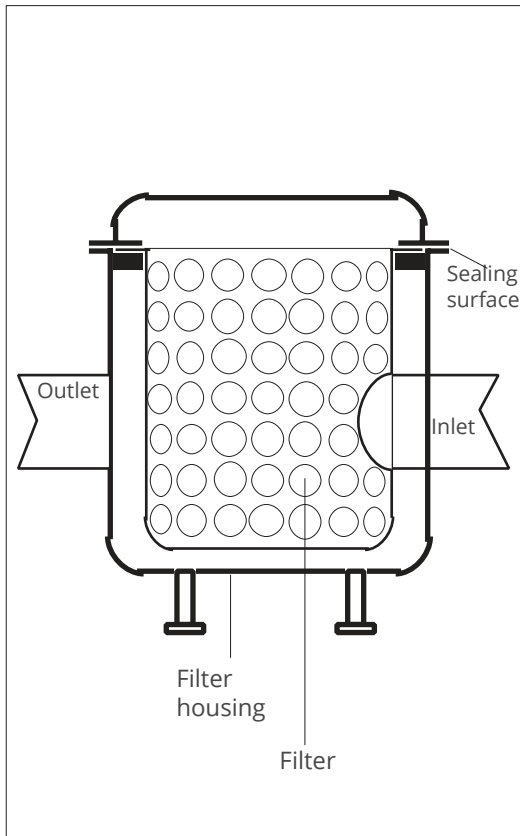

Sea water filters are very varied in appearance, but despite this they contain the same components internally: a filter housing, a filter, an inlet, an outlet, and a sealing surface between filter and housing.

Sea water filters are naturally exposed to erosion / corrosion and bimetallic corrosion.

The method described below is a long lasting method for refurbishment with proper surface preparation at a grit blasting facility.

1. Disassemble the filter and blast acc. to Wencon surface preparation, next page.
2. Fill corroded spots with Wencon Cream or Rapid. If the sealing surface of the filter is corroded, make first an application of a thin layer of Wencon.
3. After the first layer has semi-hardened mix and apply Wencon Coating, white. Apply with a radiator brush from which a half of the bristles have been cut away. When the coat has cured to a sticky consistency, apply a final coat of Wencon Coating, blue.
4. Now clean carefully the sealing surface of the filter and apply a layer of Wencon Release Agent. Then apply a suitable layer of Wencon Cream or Rapid on the sealing surface of the filter housing and fit the filter into place. A new sealing surface is thus established. After curing, the filter can be lifted out again and a gasket can be fitted. In a number of cases the gasket will not be necessary.

Alternative products: Wencon Ceramic products

Wencon surface preparation

Choose the relevant surface preparation, depending on the nature of the job.

Surface preparation using dry blasting methods:

Application with Wencon products on a dry surface, at minimum 3°C above dew point.

1. Blast the machine part to SA 2,5 using sharp-edged blasting media, to a roughness of min. 75 microns.
2. Leave the part for sweating out salts in a warm place for at least 12 hours or heat it up to 30 - 40°C (86-104 °F) using gas torches.
3. Blast again to SA 2,5, prior to the application.
4. For parts containing a lot of water and salt, it may be necessary to repeat point 2 and 3, until the surface remains light grey, for at least 2 hours after blasting.
5. For optimal adhesion of Wencon products, always use Wencon Bio Cleaner or Wencon Cleaner prior to application. Follow one of below two methods:
 - 5.1 **Wencon Bio Cleaner**
Wet surface: Apply Wencon Bio Cleaner and let it work for 5-10 min. If necessary use a brush, to make sure the surface is clean. Rinse off with clean water and wipe off with an absorbing cloth.

Dry surface: Apply Wencon Bio Cleaner and let it work for 5-10 min. If necessary use a brush, to make sure the surface is clean. Rinse off with clean water and dry with an absorbing cloth or with compressed air for a completely dry surface. Hereafter any Wencon products can be applied.
 - 5.2 **Wencon Cleaner**
 After surface preparation, apply Wencon Cleaner with a brush and allow the product to evaporate before applying other Wencon products. Wencon Cleaner is non-flammable. Use only in large or well ventilated rooms.

Surface preparation using wet/damp methods:

Water jet the entire surface with water and sand to a standard equal, to SA 2,5 as described above.

If the surface is left wet after surface preparation, is it important to dry out the surface or alternatively use a Wencon UW product.

Surface preparation for emergency/temporary applications:

If above surface preparation methods are not possible, it may be necessary to use one of below methods:

- Blasting
- Grinding
- Needle Gunning

In emergency / temporary applications it may be difficult to prepare the surface according to above methods. In any case, it is important to clean the surface to SA 2,5 and 75 microns roughness. If possible dry the surface before applying. If not possible, use Wencon UW products.

For further information on Wencon surface preparation, please contact our Area Sales Managers.

Sealing ring seats - corrosion

APPLICATION DATA SHEET No. 141

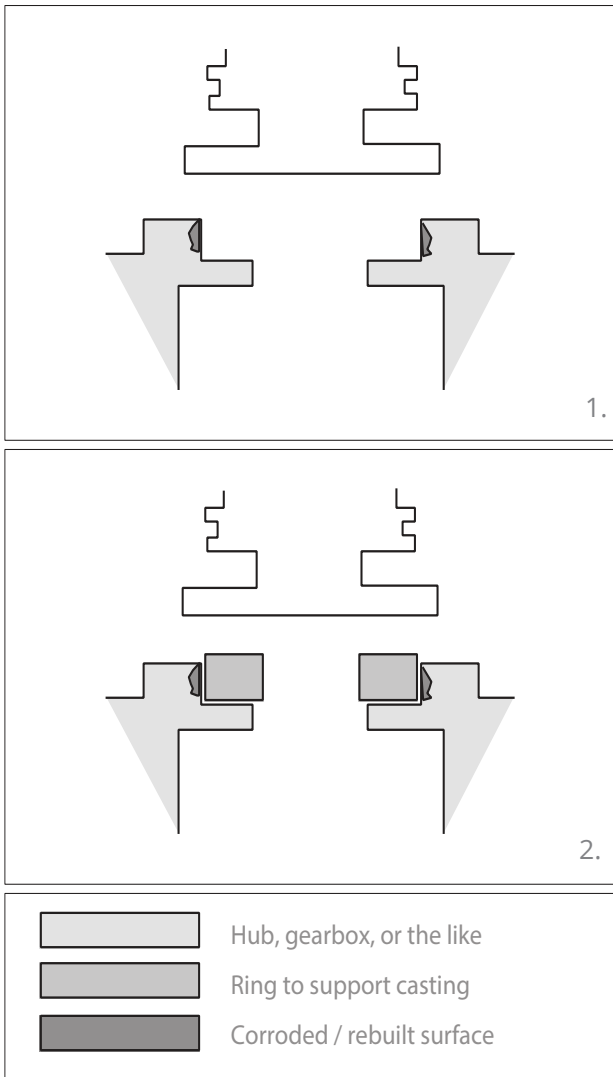

Corroded sealing ring seats in a gear box or in the hub in propeller head, etc., may suffer from either bimetallic corrosion or erosion/corrosion due to leakage and fluid flow.

This is a temporary repair solution to the seal in the gearbox. It is not advised to have direct contact between the Wencon material and metal, if there is high friction due to the high rotation.

But in this case, the Wencon material will be in contact with the seal and is therefore ideal.

Method 1: build and grind to fit

1. Grind the repair area acc. to Wencon surface preparation, next page.
2. Mix and apply a suitable layer of Wencon Ceramic Cream
3. After curing, grind or machine the surfaces to the required shape.

Method 2 : Cast to fit

To avoid grinding or machining, make a ring in the correct dimensions and use it to support the casting during the curing.

1. Grind the attacked surface acc. to Wencon surface preparation, next page.
2. Mix and apply a suitable layer of Wencon Ceramic Cream and fill it into the space between the casting ring and the surface of the hub.

If the ring is made of metal, apply a thin film of Wencon Release Agent before casting.

If the ring is made of PE plastic or the like, release Agent is not needed.

The application will be finished after the product is cured and the rings is removed.

Alternative products: Wencon Cream or Wencon Rapid.

Wencon surface preparation

Choose the relevant surface preparation, depending on the nature of the job.

Surface preparation using dry blasting methods:

Application with Wencon products on a dry surface, at minimum 3°C above dew point.

1. Blast the machine part to SA 2,5 using sharp-edged blasting media, to a roughness of min. 75 microns.
2. Leave the part for sweating out salts in a warm place for at least 12 hours or heat it up to 30 - 40°C (86-104 °F) using gas torches.
3. Blast again to SA 2,5, prior to the application.
4. For parts containing a lot of water and salt, it may be necessary to repeat point 2 and 3, until the surface remains light grey, for at least 2 hours after blasting.
5. For optimal adhesion of Wencon products, always use Wencon Bio Cleaner or Wencon Cleaner prior to application. Follow one of below two methods:
 - 5.1 **Wencon Bio Cleaner**
Wet surface: Apply Wencon Bio Cleaner and let it work for 5-10 min. If necessary use a brush, to make sure the surface is clean. Rinse off with clean water and wipe off with an absorbing cloth.

Dry surface: Apply Wencon Bio Cleaner and let it work for 5-10 min. If necessary use a brush, to make sure the surface is clean. Rinse off with clean water and dry with an absorbing cloth or with compressed air for a completely dry surface. Hereafter any Wencon products can be applied.
 - 5.2 **Wencon Cleaner**
 After surface preparation, apply Wencon Cleaner with a brush and allow the product to evaporate before applying other Wencon products. Wencon Cleaner is non-flammable. Use only in large or well ventilated rooms.

Surface preparation using wet/damp methods:

Water jet the entire surface with water and sand to a standard equal, to SA 2,5 as described above.

If the surface is left wet after surface preparation, is it important to dry out the surface or alternatively use a Wencon UW product.

Surface preparation for emergency/temporary applications:

If above surface preparation methods are not possible, it may be necessary to use one of below methods:

- Blasting
- Grinding
- Needle Gunning

In emergency / temporary applications it may be difficult to prepare the surface according to above methods. In any case, it is important to clean the surface to SA 2,5 and 75 microns roughness. If possible dry the surface before applying. If not possible, use Wencon UW products.

For further information on Wencon surface preparation, please contact our Area Sales Managers.

Shafts - damaged

APPLICATION DATA SHEET No. 104

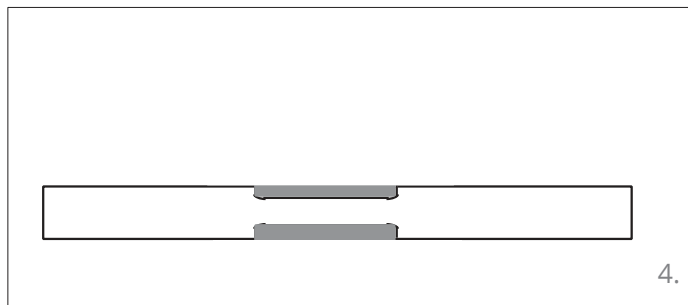
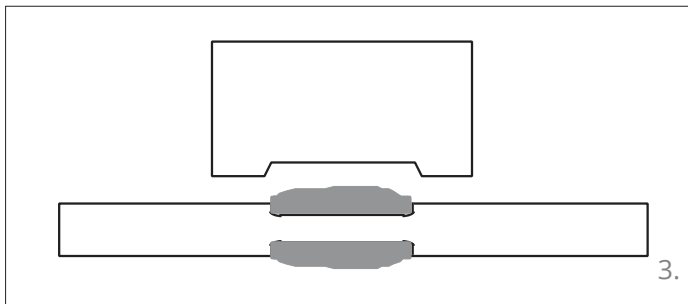
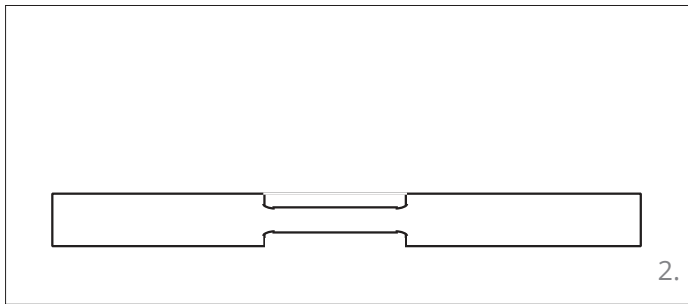
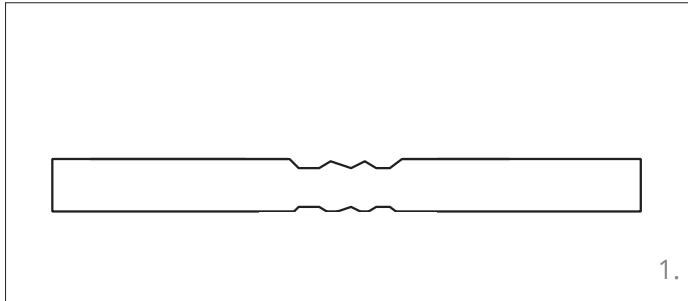

Before repairs, make sure that the shaft has enough structural strength to support normal operation.

1. Place the shaft in the lathe.
2. Turn the shaft as shown. Finish off with a rough turning or a thread.
3. Mix a suitable amount of Wencon Cream or Rapid and apply one layer to the shaft. If necessary, make a spatula as shown.
4. When cured, turn to final size. If so desired, an interference fit can be machined or the bearing can be glued.

Variations:

Rather than using the lathe, the first turn can be replaced by grinding with an angle-grinder.

A couple of bushes must also be made with the internal diameter of the final size required. These bushes should be approx. twice the length of the damaged area, and be used for casting of the new surface on the shaft. The bushes must be treated with Wencon Release Agent prior to casting.

Alternative products: [Wencon Ceramic Cream](#)

Wencon surface preparation

Choose the relevant surface preparation, depending on the nature of the job.

Surface preparation using dry blasting methods:

Application with Wencon products on a dry surface, at minimum 3°C above dew point.

1. Blast the machine part to SA 2,5 using sharp-edged blasting media, to a roughness of min. 75 microns.
2. Leave the part for sweating out salts in a warm place for at least 12 hours or heat it up to 30 - 40°C (86-104 °F) using gas torches.
3. Blast again to SA 2,5, prior to the application.
4. For parts containing a lot of water and salt, it may be necessary to repeat point 2 and 3, until the surface remains light grey, for at least 2 hours after blasting.
5. For optimal adhesion of Wencon products, always use Wencon Bio Cleaner or Wencon Cleaner prior to application. Follow one of below two methods:
 - 5.1 **Wencon Bio Cleaner**
Wet surface: Apply Wencon Bio Cleaner and let it work for 5-10 min. If necessary use a brush, to make sure the surface is clean. Rinse off with clean water and wipe off with an absorbing cloth.

Dry surface: Apply Wencon Bio Cleaner and let it work for 5-10 min. If necessary use a brush, to make sure the surface is clean. Rinse off with clean water and dry with an absorbing cloth or with compressed air for a completely dry surface. Hereafter any Wencon products can be applied.
 - 5.2 **Wencon Cleaner**
 After surface preparation, apply Wencon Cleaner with a brush and allow the product to evaporate before applying other Wencon products. Wencon Cleaner is non-flammable. Use only in large or well ventilated rooms.

Surface preparation using wet/damp methods:

Water jet the entire surface with water and sand to a standard equal, to SA 2,5 as described above.

If the surface is left wet after surface preparation, is it important to dry out the surface or alternatively use a Wencon UW product.

Surface preparation for emergency/temporary applications:

If above surface preparation methods are not possible, it may be necessary to use one of below methods:

- Blasting
- Grinding
- Needle Gunning

In emergency / temporary applications it may be difficult to prepare the surface according to above methods. In any case, it is important to clean the surface to SA 2,5 and 75 microns roughness. If possible dry the surface before applying. If not possible, use Wencon UW products.

For further information on Wencon surface preparation, please contact our Area Sales Managers.

Stern tubes - casting of seats

APPLICATION DATA SHEET No. 117

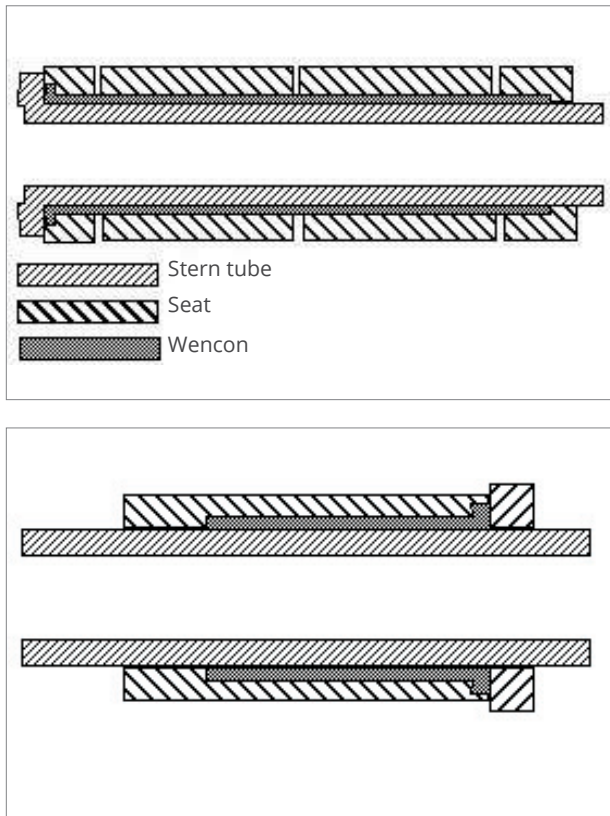

Some of the advantages in the technique for casting seats for stern tubes are: better mating surfaces, no demand for line boring.

1. The seat shall be given a rough and clean surface. The diameter shall be approx. 8 mm (0,32 inch) larger than the stern tube.
2. Drill holes in the bottom of the seat (a) for injection. The number of holes depends on the length. Drill holes in the top for ventilation. All the holes may be tapered to make it easy to mount bolts after injection has been finished.
3. In the bottom of the tube, an O-ring or the like creates a seal to prevent the casting material from escaping.
4. Mount the stern tube in the desired position. Seal the outer flange with a sealant or with Wencon Rapid.
5. The temperature of the working area shall be 15-20°C (51-68°F). Avoid heating of the stern tube.
6. Use an air driven sealant gun for the injection.
7. Calculate the approx. consumption of casting material.
8. Mix one unit of Wencon Coating and fill it in an empty cartridge (can be supplied from Wencon) and inject into the rear hole. Repeat this until the casting has reached the next hole, plug the first hole and continue in the second. Repeat until the entire gap is filled.

This technique is approved by B.V.

The bottom drawing shows the other end of a stern tube that shall be treated the same way.

Wencon surface preparation

Choose the relevant surface preparation, depending on the nature of the job.

Surface preparation using dry blasting methods:

Application with Wencon products on a dry surface, at minimum 3°C above dew point.

1. Blast the machine part to SA 2,5 using sharp-edged blasting media, to a roughness of min. 75 microns.
2. Leave the part for sweating out salts in a warm place for at least 12 hours or heat it up to 30 - 40°C (86-104 °F) using gas torches.
3. Blast again to SA 2,5, prior to the application.
4. For parts containing a lot of water and salt, it may be necessary to repeat point 2 and 3, until the surface remains light grey, for at least 2 hours after blasting.
5. For optimal adhesion of Wencon products, always use Wencon Bio Cleaner or Wencon Cleaner prior to application. Follow one of below two methods:
 - 5.1 **Wencon Bio Cleaner**
Wet surface: Apply Wencon Bio Cleaner and let it work for 5-10 min. If necessary use a brush, to make sure the surface is clean. Rinse off with clean water and wipe off with an absorbing cloth.

Dry surface: Apply Wencon Bio Cleaner and let it work for 5-10 min. If necessary use a brush, to make sure the surface is clean. Rinse off with clean water and dry with an absorbing cloth or with compressed air for a completely dry surface. Hereafter any Wencon products can be applied.
 - 5.2 **Wencon Cleaner**
 After surface preparation, apply Wencon Cleaner with a brush and allow the product to evaporate before applying other Wencon products. Wencon Cleaner is non-flammable. Use only in large or well ventilated rooms.

Surface preparation using wet/damp methods:

Water jet the entire surface with water and sand to a standard equal, to SA 2,5 as described above.

If the surface is left wet after surface preparation, is it important to dry out the surface or alternatively use a Wencon UW product.

Surface preparation for emergency/temporary applications:

If above surface preparation methods are not possible, it may be necessary to use one of below methods:

- Blasting
- Grinding
- Needle Gunning

In emergency / temporary applications it may be difficult to prepare the surface according to above methods. In any case, it is important to clean the surface to SA 2,5 and 75 microns roughness. If possible dry the surface before applying. If not possible, use Wencon UW products.

For further information on Wencon surface preparation, please contact our Area Sales Managers.

Tank holes - not leaking

APPLICATION DATA SHEET No. 129

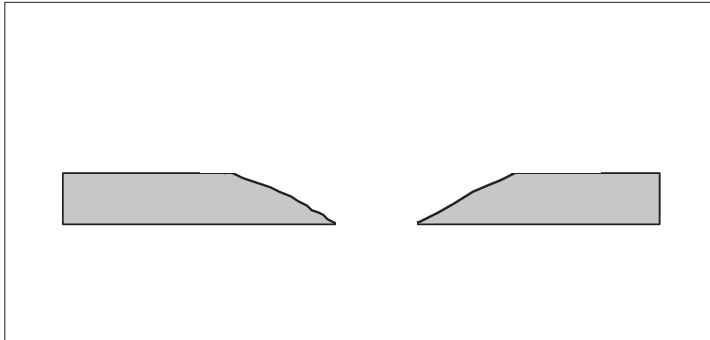

When repairing leaking tanks, the best result is obtained by repairing on the pressure side.

Often, when a tank is leaking, the corrosion is not only isolated to the leak, but is also present in the surrounding area. Make sure to repair the entire affected area, to stop further corrosion.

1. Carry out surface preparation acc. to Wencon surface preparation, next page.
2. Mix and apply a suitable amount of Wencon Rapid. Make sure to get a good contact between the Wencon and the substrate. Avoid air entrapment.
3. For extra security, it is advisable to reinforce the application by the means of a steel plate, grit blasted or ground on the mating surface and fixed into the Wencon product before curing. If the surface of the substrate is shaped, give the plate the approximate same shape before bedding it on-to the repair. Make sure, that the plate will get in good contact with the Wencon material.
4. To protect against further bi-metallic corrosion, treat the entire top of the repair surface with Wencon Coating, white and blue.

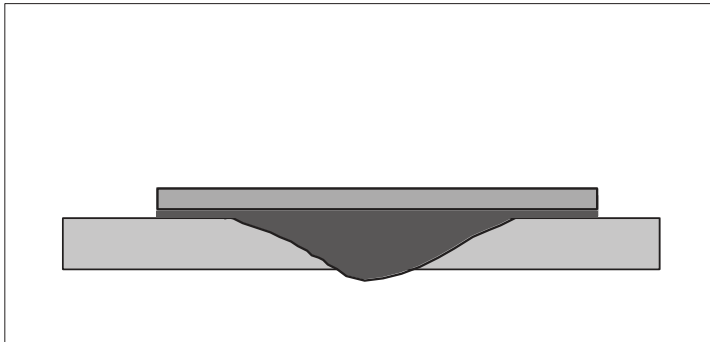
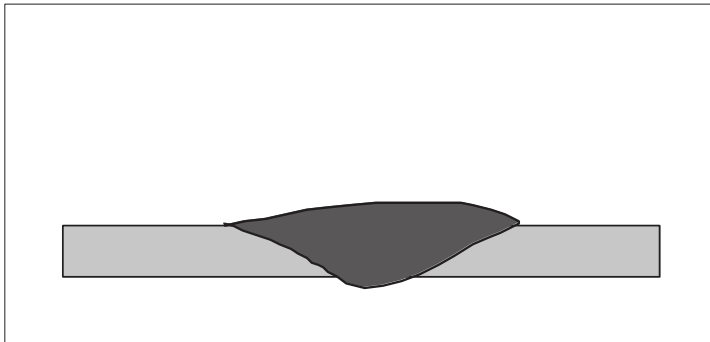

Alternative products: Wencon Ceramic products

Wencon surface preparation

Choose the relevant surface preparation, depending on the nature of the job.

Surface preparation using dry blasting methods:

Application with Wencon products on a dry surface, at minimum 3°C above dew point.

1. Blast the machine part to SA 2,5 using sharp-edged blasting media, to a roughness of min. 75 microns.
2. Leave the part for sweating out salts in a warm place for at least 12 hours or heat it up to 30 - 40°C (86-104 °F) using gas torches.
3. Blast again to SA 2,5, prior to the application.
4. For parts containing a lot of water and salt, it may be necessary to repeat point 2 and 3, until the surface remains light grey, for at least 2 hours after blasting.
5. For optimal adhesion of Wencon products, always use Wencon Bio Cleaner or Wencon Cleaner prior to application. Follow one of below two methods:
 - 5.1 **Wencon Bio Cleaner**
Wet surface: Apply Wencon Bio Cleaner and let it work for 5-10 min. If necessary use a brush, to make sure the surface is clean. Rinse off with clean water and wipe off with an absorbing cloth.

Dry surface: Apply Wencon Bio Cleaner and let it work for 5-10 min. If necessary use a brush, to make sure the surface is clean. Rinse off with clean water and dry with an absorbing cloth or with compressed air for a completely dry surface. Hereafter any Wencon products can be applied.
 - 5.2 **Wencon Cleaner**
 After surface preparation, apply Wencon Cleaner with a brush and allow the product to evaporate before applying other Wencon products. Wencon Cleaner is non-flammable. Use only in large or well ventilated rooms.

Surface preparation using wet/damp methods:

Water jet the entire surface with water and sand to a standard equal, to SA 2,5 as described above.

If the surface is left wet after surface preparation, is it important to dry out the surface or alternatively use a Wencon UW product.

Surface preparation for emergency/temporary applications:

If above surface preparation methods are not possible, it may be necessary to use one of below methods:

- Blasting
- Grinding
- Needle Gunning

In emergency / temporary applications it may be difficult to prepare the surface according to above methods. In any case, it is important to clean the surface to SA 2,5 and 75 microns roughness. If possible dry the surface before applying. If not possible, use Wencon UW products.

For further information on Wencon surface preparation, please contact our Area Sales Managers.

Tanks - emergency repair of leaking cracks

APPLICATION DATA SHEET No. 146

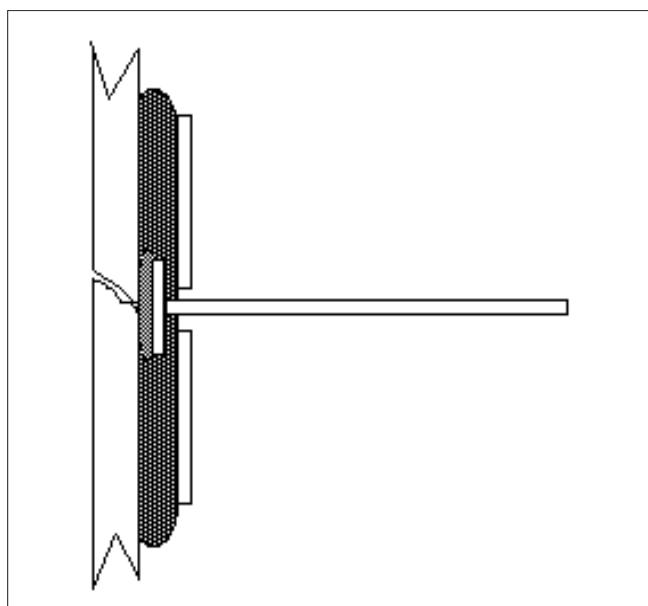
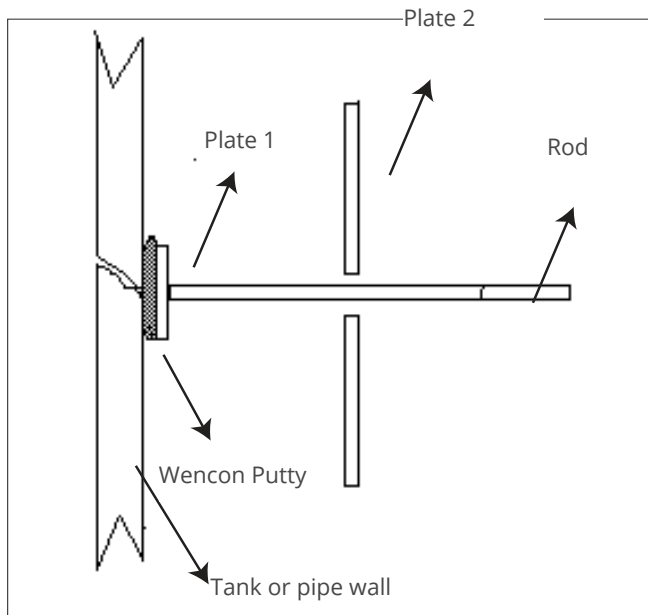

Cracks in tanks, pipes and other structures.

If possible, reduce or eliminate pump pressure during application.

The technique involves two steps. First, the leak must be stopped, thereafter, it must be secured.

1. Prepare three tools

One small steel plate (Plate 1.) big enough to cover the leak, and larger than the hole in the large plate (see below).

One larger steel plate (Plate 2.) to cover an area of 100 x 100 mm or larger. The size has influence on the strength of the repair. In the middle of this plate, drill a hole for the rod (see below). Clean the surface thoroughly acc. to Wencon surface preparation, next page.

One rod (could be a large screwdriver), long enough to serve its purpose (see below)

2. Stop the leak

Mix a suitable amount of Wencon Putty and place it directly in the leak. If pressure is high, await semi curing, that will make the Putty more stiff. Before the Putty cures, press and hold it by the means of the small plate, and fixate it with the rod. This will stop the leak.

As an alternative, a wooden plug can be hammered into the leak, to take most of the pressure.

3. Secure the leak

Grind an area around the leak, slightly larger than the large steel plate. Clean it using the Wencon Bio Cleaner. Mix and apply a thick layer of Wencon Rapid to the surface. Make sure that the thickness exceeds the combined thickness of the Putty and the small steel plate. Mount the large steel plate into the un-cured Wencon Rapid, and hold until full cure.

Variation

On applications where the crack is not on a flat surface, the plates will have to be shaped accordingly.

For quick cure, apply heat up to 100°C (340°F).

Alternative products: Wencon UW products

Wencon surface preparation

Choose the relevant surface preparation, depending on the nature of the job.

Surface preparation using dry blasting methods:

Application with Wencon products on a dry surface, at minimum 3°C above dew point.

1. Blast the machine part to SA 2,5 using sharp-edged blasting media, to a roughness of min. 75 microns.
2. Leave the part for sweating out salts in a warm place for at least 12 hours or heat it up to 30 - 40°C (86-104 °F) using gas torches.
3. Blast again to SA 2,5, prior to the application.
4. For parts containing a lot of water and salt, it may be necessary to repeat point 2 and 3, until the surface remains light grey, for at least 2 hours after blasting.
5. For optimal adhesion of Wencon products, always use Wencon Bio Cleaner or Wencon Cleaner prior to application. Follow one of below two methods:
 - 5.1 **Wencon Bio Cleaner**
 Wet surface: Apply Wencon Bio Cleaner and let it work for 5-10 min. If necessary use a brush, to make sure the surface is clean. Rinse off with clean water and wipe off with an absorbing cloth.

 Dry surface: Apply Wencon Bio Cleaner and let it work for 5-10 min. If necessary use a brush, to make sure the surface is clean. Rinse off with clean water and dry with an absorbing cloth or with compressed air for a completely dry surface. Hereafter any Wencon products can be applied.
 - 5.2 **Wencon Cleaner**
 After surface preparation, apply Wencon Cleaner with a brush and allow the product to evaporate before applying other Wencon products. Wencon Cleaner is non-flammable. Use only in large or well ventilated rooms.

Surface preparation using wet/damp methods:

Water jet the entire surface with water and sand to a standard equal, to SA 2,5 as described above.

If the surface is left wet after surface preparation, is it important to dry out the surface or alternatively use a Wencon UW product.

Surface preparation for emergency/temporary applications:

If above surface preparation methods are not possible, it may be necessary to use one of below methods:

- Blasting
- Grinding
- Needle Gunning

In emergency / temporary applications it may be difficult to prepare the surface according to above methods. In any case, it is important to clean the surface to SA 2,5 and 75 microns roughness. If possible dry the surface before applying. If not possible, use Wencon UW products.

For further information on Wencon surface preparation, please contact our Area Sales Managers.

Tanks - pitting

APPLICATION DATA SHEET No. 145

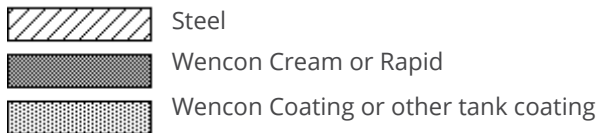
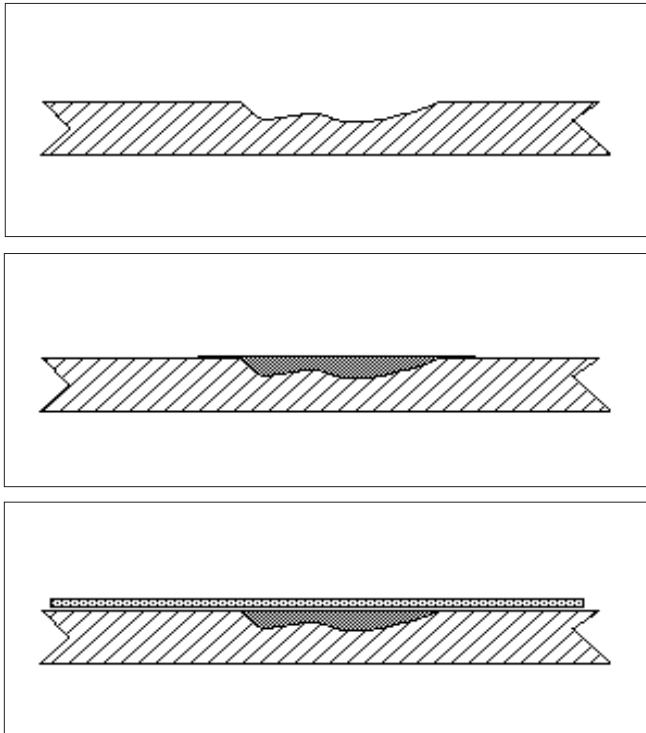

Whether the tank is coated or not, the area with pitting shall be cleaned thoroughly acc. to Wencon surface preparation, next page.

1. After surface treatment, mix and apply a suitable amount of Wencon Cream or Rapid (use Rapid for quick curing and/or deep pitting on vertical surfaces).

Make sure the material gets in good physical contact with the substrate.

2a.Coating with Wencon Coating:

After 1-2 hours curing, apply first layer of Wencon Coating, white, and after yet another hour (while the white coating is still a bit tacky) apply the final coat of Wencon Coating, blue.

2b.Coating with other brands of tank coating:

Apply first layer of your own tank coating before the Wencon Cream or Rapid has fully cured, to ensure a the best adhesion.

Alternative products: Wencon Ceramic products

Wencon surface preparation

Choose the relevant surface preparation, depending on the nature of the job.

Surface preparation using dry blasting methods:

Application with Wencon products on a dry surface, at minimum 3°C above dew point.

1. Blast the machine part to SA 2,5 using sharp-edged blasting media, to a roughness of min. 75 microns.
2. Leave the part for sweating out salts in a warm place for at least 12 hours or heat it up to 30 - 40°C (86-104 °F) using gas torches.
3. Blast again to SA 2,5, prior to the application.
4. For parts containing a lot of water and salt, it may be necessary to repeat point 2 and 3, until the surface remains light grey, for at least 2 hours after blasting.
5. For optimal adhesion of Wencon products, always use Wencon Bio Cleaner or Wencon Cleaner prior to application. Follow one of below two methods:
 - 5.1 **Wencon Bio Cleaner**
Wet surface: Apply Wencon Bio Cleaner and let it work for 5-10 min. If necessary use a brush, to make sure the surface is clean. Rinse off with clean water and wipe off with an absorbing cloth.

Dry surface: Apply Wencon Bio Cleaner and let it work for 5-10 min. If necessary use a brush, to make sure the surface is clean. Rinse off with clean water and dry with an absorbing cloth or with compressed air for a completely dry surface. Hereafter any Wencon products can be applied.
 - 5.2 **Wencon Cleaner**
 After surface preparation, apply Wencon Cleaner with a brush and allow the product to evaporate before applying other Wencon products. Wencon Cleaner is non-flammable. Use only in large or well ventilated rooms.

Surface preparation using wet/damp methods:

Water jet the entire surface with water and sand to a standard equal, to SA 2,5 as described above.

If the surface is left wet after surface preparation, is it important to dry out the surface or alternatively use a Wencon UW product.

Surface preparation for emergency/temporary applications:

If above surface preparation methods are not possible, it may be necessary to use one of below methods:

- Blasting
- Grinding
- Needle Gunning

In emergency / temporary applications it may be difficult to prepare the surface according to above methods. In any case, it is important to clean the surface to SA 2,5 and 75 microns roughness. If possible dry the surface before applying. If not possible, use Wencon UW products.

For further information on Wencon surface preparation, please contact our Area Sales Managers.

Tube end plates - corrosion

APPLICATION DATA SHEET No. 118

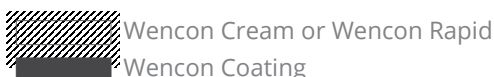
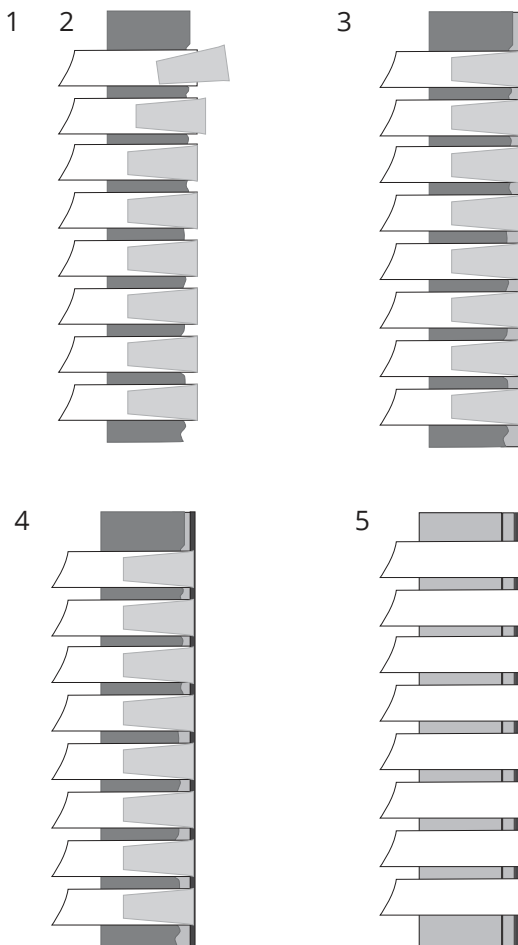
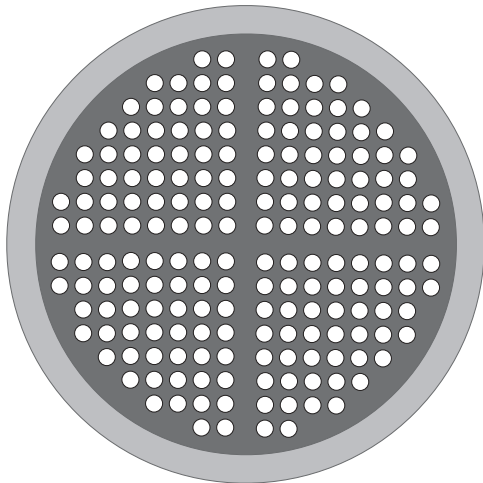

Corroded tube end plates can be rebuilt and protected against further corrosion using a Wencon Solution. However the result greatly depends on the preparations and accuracy of the work done. These are the steps we recommend.

1. Insert plugs in the tubes to protect these while grit blasting. Grit blast the tube end plate acc. to Wencon surface preparation, see next page.
2. Replace the plugs with new plugs treated with Wencon Release Agent. Knock the plugs all the way into the tubes and ensure they sit level/flush .
3. Mix and Wencon Cream or Wencon Rapid and apply to the the surface untill it is sufficiently rebuilt.
4. While the first layer is curing, Semi-cured, apply one layer of Wencon Coating, it is okay if it covers the plugs.
5. Remove the plugs while the coating is still wet.

NB. If there is a need to rebuild a sealing surface that mates with the end cover, wait until the above application has been done, and then build up the sealing surface as follows.

1. First apply a coat of Wencon Release Agent to the flange, then apply a coat of Wencon Cream on to the sealing surface, and then fit the cover into position before curing.
2. Finally, apply two coats of Wencon Coating using thin hard felt paint roller. Avoid getting coating material into the tube ends.

Wencon surface preparation

Choose the relevant surface preparation, depending on the nature of the job.

Surface preparation using dry blasting methods:

Application with Wencon products on a dry surface, at minimum 3°C above dew point.

1. Blast the machine part to SA 2,5 using sharp-edged blasting media, to a roughness of min. 75 microns.
2. Leave the part for sweating out salts in a warm place for at least 12 hours or heat it up to 30 - 40°C (86-104 °F) using gas torches.
3. Blast again to SA 2,5, prior to the application.
4. For parts containing a lot of water and salt, it may be necessary to repeat point 2 and 3, until the surface remains light grey, for at least 2 hours after blasting.
5. For optimal adhesion of Wencon products, always use Wencon Bio Cleaner or Wencon Cleaner prior to application. Follow one of below two methods:
 - 5.1 **Wencon Bio Cleaner**
Wet surface: Apply Wencon Bio Cleaner and let it work for 5-10 min. If necessary use a brush, to make sure the surface is clean. Rinse off with clean water and wipe off with an absorbing cloth.

Dry surface: Apply Wencon Bio Cleaner and let it work for 5-10 min. If necessary use a brush, to make sure the surface is clean. Rinse off with clean water and dry with an absorbing cloth or with compressed air for a completely dry surface. Hereafter any Wencon products can be applied.
 - 5.2 **Wencon Cleaner**
 After surface preparation, apply Wencon Cleaner with a brush and allow the product to evaporate before applying other Wencon products. Wencon Cleaner is non-flammable. Use only in large or well ventilated rooms.

Surface preparation using wet/damp methods:

Water jet the entire surface with water and sand to a standard equal, to SA 2,5 as described above.

If the surface is left wet after surface preparation, is it important to dry out the surface or alternatively use a Wencon UW product.

Surface preparation for emergency/temporary applications:

If above surface preparation methods are not possible, it may be necessary to use one of below methods:

- Blasting
- Grinding
- Needle Gunning

In emergency / temporary applications it may be difficult to prepare the surface according to above methods. In any case, it is important to clean the surface to SA 2,5 and 75 microns roughness. If possible dry the surface before applying. If not possible, use Wencon UW products.

For further information on Wencon surface preparation, please contact our Area Sales Managers.

Turbo charger casings - sealing cracks

APPLICATION DATA SHEET No. 154

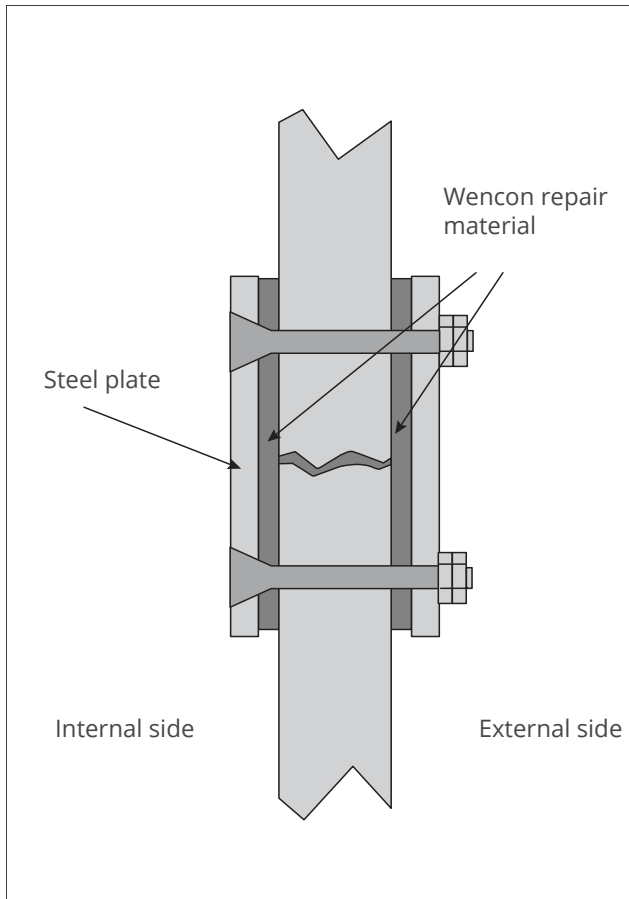

Remarks

This application is meant to seal a well stabilised crack. Application will only work, if the crack is stabilised

Stabilise the crack

Find the ends, stop the crack and stabilise it as described by suppliers of crack repairs.

Seal the crack

1. Prepare the entire area internally as well as externally acc. to Wencon surface preparation, next page.

Inside job

2. Make two pieces of metal plate, approx. 100 mm (4 inch) wide and 50-100 mm (2-4 inch) longer than the crack. The plates shall cover the repair area.
3. Form it in the shape of the crack. Use welding, bending or the like.
4. Drill holes as shown in the plates.
5. Clean the area again. Also the metal plate.
6. Mix and apply a layer of Wencon Hi-Temp or Wencon Ceramic Coating directly in the crack in a thickness of min. 5 mm (0,2 inch) as shown in the ill.

7. Before curing, place the prepared metal plates over the crack and make sure to get good contact. Remove excess material.

8. After semi cure the work with extra securing of the plate can start. Drill and tap holes in the engine block as shown, and mount bolts as shown. Secure the bolts with an anaerobic adhesive, bolt wires or the like.

Remarks

There is always a risk when mounting loose parts in a turbo charger. Calculate the risk in the situation and act accordingly.

Wencon surface preparation

Choose the relevant surface preparation, depending on the nature of the job.

Surface preparation using dry blasting methods:

Application with Wencon products on a dry surface, at minimum 3°C above dew point.

1. Blast the machine part to SA 2,5 using sharp-edged blasting media, to a roughness of min. 75 microns.
2. Leave the part for sweating out salts in a warm place for at least 12 hours or heat it up to 30 - 40°C (86-104 °F) using gas torches.
3. Blast again to SA 2,5, prior to the application.
4. For parts containing a lot of water and salt, it may be necessary to repeat point 2 and 3, until the surface remains light grey, for at least 2 hours after blasting.
5. For optimal adhesion of Wencon products, always use Wencon Bio Cleaner or Wencon Cleaner prior to application. Follow one of below two methods:
 - 5.1 **Wencon Bio Cleaner**
Wet surface: Apply Wencon Bio Cleaner and let it work for 5-10 min. If necessary use a brush, to make sure the surface is clean. Rinse off with clean water and wipe off with an absorbing cloth.

Dry surface: Apply Wencon Bio Cleaner and let it work for 5-10 min. If necessary use a brush, to make sure the surface is clean. Rinse off with clean water and dry with an absorbing cloth or with compressed air for a completely dry surface. Hereafter any Wencon products can be applied.
 - 5.2 **Wencon Cleaner**
 After surface preparation, apply Wencon Cleaner with a brush and allow the product to evaporate before applying other Wencon products. Wencon Cleaner is non-flammable. Use only in large or well ventilated rooms.

Surface preparation using wet/damp methods:

Water jet the entire surface with water and sand to a standard equal, to SA 2,5 as described above.

If the surface is left wet after surface preparation, is it important to dry out the surface or alternatively use a Wencon UW product.

Surface preparation for emergency/temporary applications:

If above surface preparation methods are not possible, it may be necessary to use one of below methods:

- Blasting
- Grinding
- Needle Gunning

In emergency / temporary applications it may be difficult to prepare the surface according to above methods. In any case, it is important to clean the surface to SA 2,5 and 75 microns roughness. If possible dry the surface before applying. If not possible, use Wencon UW products.

For further information on Wencon surface preparation, please contact our Area Sales Managers.

Valve seat - corrosion

APPLICATION DATA SHEET No. 107

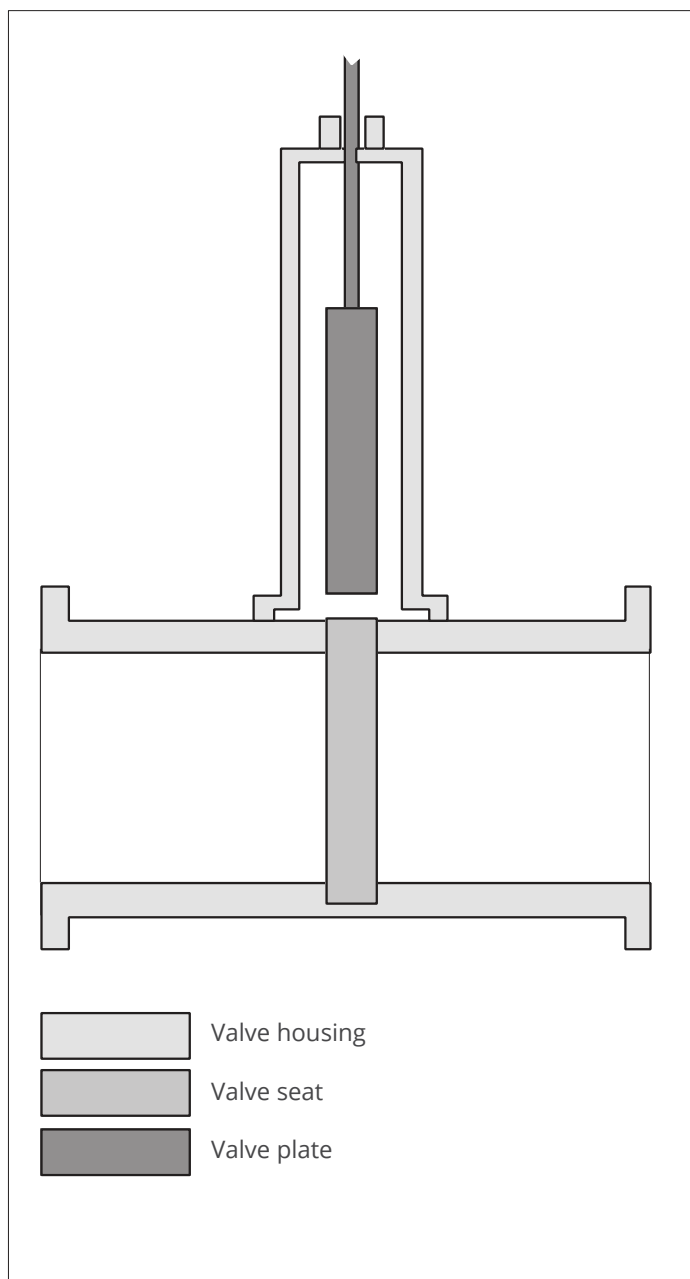

Leaks in valves often occur, due to corrosion in the seating. As a rule the valve is constructed using a number of different metals. Therefore there is every possibility of light acidic agents, such as sea water, causing bimetallic corrosion.

This application, deals only with emergency repair of a corroded seat. The complete renovation of valves are dealt with in another application sheet. Whether the valves in question are plate valves or butterfly and non-return valves, the method of application is much the same.

Clean the corroded seat acc. to Wencon surface preparation, next page.

Apply a coat of Wencon Release Agent to the valve plate. This will prevent adhesion. Mix and apply an adequate amount of Wencon Cream or Rapid to the valve seat and close the valve immediately afterwards.

When curing is completed open the valve and grind the seating edges to shape. Wencon adheres to all metals. Wencon retains its form and size during curing.

Please refer also to the application instructions accompanying the Wencon product.

Wencon surface preparation

Choose the relevant surface preparation, depending on the nature of the job.

Surface preparation using dry blasting methods:

Application with Wencon products on a dry surface, at minimum 3°C above dew point.

1. Blast the machine part to SA 2,5 using sharp-edged blasting media, to a roughness of min. 75 microns.
2. Leave the part for sweating out salts in a warm place for at least 12 hours or heat it up to 30 - 40°C (86-104 °F) using gas torches.
3. Blast again to SA 2,5, prior to the application.
4. For parts containing a lot of water and salt, it may be necessary to repeat point 2 and 3, until the surface remains light grey, for at least 2 hours after blasting.
5. For optimal adhesion of Wencon products, always use Wencon Bio Cleaner or Wencon Cleaner prior to application. Follow one of below two methods:
 - 5.1 **Wencon Bio Cleaner**
Wet surface: Apply Wencon Bio Cleaner and let it work for 5-10 min. If necessary use a brush, to make sure the surface is clean. Rinse off with clean water and wipe off with an absorbing cloth.

Dry surface: Apply Wencon Bio Cleaner and let it work for 5-10 min. If necessary use a brush, to make sure the surface is clean. Rinse off with clean water and dry with an absorbing cloth or with compressed air for a completely dry surface. Hereafter any Wencon products can be applied.
 - 5.2 **Wencon Cleaner**
 After surface preparation, apply Wencon Cleaner with a brush and allow the product to evaporate before applying other Wencon products. Wencon Cleaner is non-flammable. Use only in large or well ventilated rooms.

Surface preparation using wet/damp methods:

Water jet the entire surface with water and sand to a standard equal, to SA 2,5 as described above.

If the surface is left wet after surface preparation, is it important to dry out the surface or alternatively use a Wencon UW product.

Surface preparation for emergency/temporary applications:

If above surface preparation methods are not possible, it may be necessary to use one of below methods:

- Blasting
- Grinding
- Needle Gunning

In emergency / temporary applications it may be difficult to prepare the surface according to above methods. In any case, it is important to clean the surface to SA 2,5 and 75 microns roughness. If possible dry the surface before applying. If not possible, use Wencon UW products.

For further information on Wencon surface preparation, please contact our Area Sales Managers.

Wear plates - casting support

APPLICATION DATA SHEET No. 119

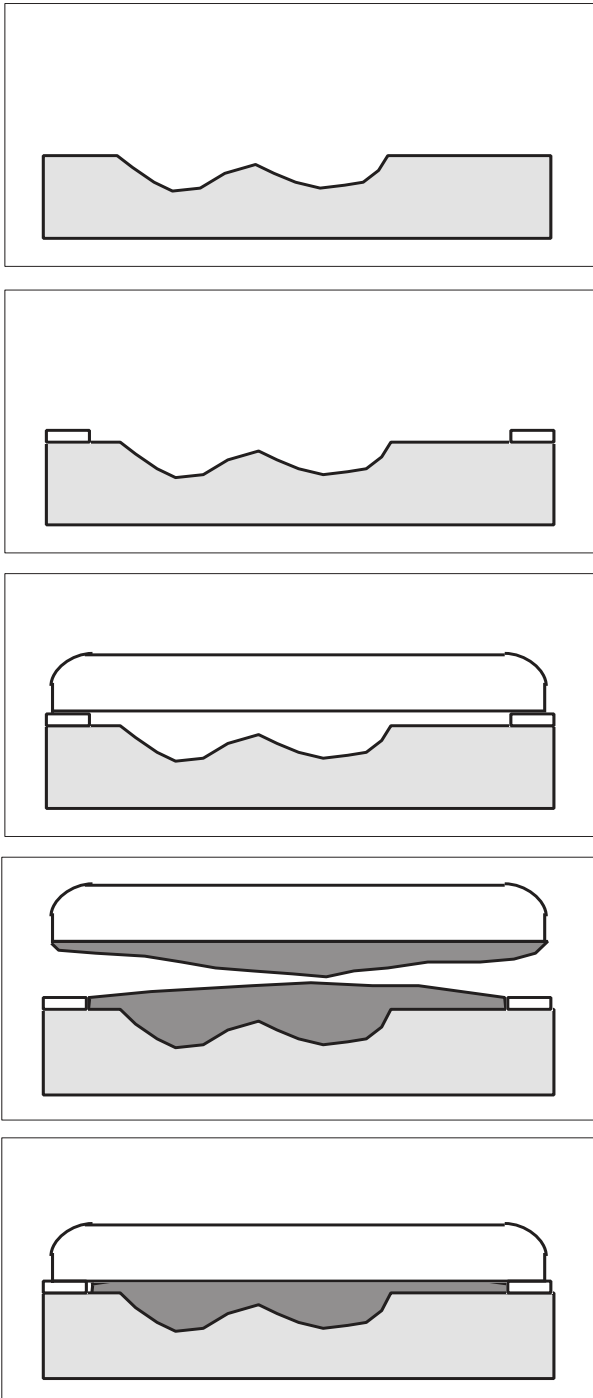

It is often the case that wear plates are replaced too late. This results in excessive wear of the surface of the seat for the plate. Welding and machining of this surface can be expensive. By using the Wencon application, these surfaces can easily be built up to exact alignment with the wear plate. In many cases it is even possible to avoid the necessity of machining the rear side of the wear plates.

1. Clean the worn surface acc. to Wencon surface preparation, next page.
2. On each seat, fix four small iron shims to guide the wear plate during the casting. They must ensure a minimum casting height of 2 mm (0,08 inch), and must be removed after casting.
3. Before casting, check the plate for correct positioning. Then apply a film of Wencon Release Agent to the rear of the plate, to prevent adhesion between the plate and Wencon. Allow the release agent to dry for at least 5 minutes.
4. Clean the worn surface with Wencon Bio Cleaner. Mix an adequate amount of Wencon Cream. Build up a layer, as shown in the diagram, on both the seat and the plate. Allow some 30% of the Wencon to be squeezed out when fitting in order to ensure a complete support.
5. Press down the plate on to the shims, either by means of the bolts that holds the plates or by means of a jack. Thereafter remove the excess Wencon material and the job is finished. Curing time depends on temperature. At 20°C (68°F) Sit will be about 10-15 hours. Curing time can be shortened at higher temperatures. After curing, remove the shims, and re tighten the plates to the required tension.

Wencon surface preparation

Choose the relevant surface preparation, depending on the nature of the job.

Surface preparation using dry blasting methods:

Application with Wencon products on a dry surface, at minimum 3°C above dew point.

1. Blast the machine part to SA 2,5 using sharp-edged blasting media, to a roughness of min. 75 microns.
2. Leave the part for sweating out salts in a warm place for at least 12 hours or heat it up to 30 - 40°C (86-104 °F) using gas torches.
3. Blast again to SA 2,5, prior to the application.
4. For parts containing a lot of water and salt, it may be necessary to repeat point 2 and 3, until the surface remains light grey, for at least 2 hours after blasting.
5. For optimal adhesion of Wencon products, always use Wencon Bio Cleaner or Wencon Cleaner prior to application. Follow one of below two methods:
 - 5.1 **Wencon Bio Cleaner**
Wet surface: Apply Wencon Bio Cleaner and let it work for 5-10 min. If necessary use a brush, to make sure the surface is clean. Rinse off with clean water and wipe off with an absorbing cloth.

Dry surface: Apply Wencon Bio Cleaner and let it work for 5-10 min. If necessary use a brush, to make sure the surface is clean. Rinse off with clean water and dry with an absorbing cloth or with compressed air for a completely dry surface. Hereafter any Wencon products can be applied.
 - 5.2 **Wencon Cleaner**
 After surface preparation, apply Wencon Cleaner with a brush and allow the product to evaporate before applying other Wencon products. Wencon Cleaner is non-flammable. Use only in large or well ventilated rooms.

Surface preparation using wet/damp methods:

Water jet the entire surface with water and sand to a standard equal, to SA 2,5 as described above.

If the surface is left wet after surface preparation, is it important to dry out the surface or alternatively use a Wencon UW product.

Surface preparation for emergency/temporary applications:

If above surface preparation methods are not possible, it may be necessary to use one of below methods:

- Blasting
- Grinding
- Needle Gunning

In emergency / temporary applications it may be difficult to prepare the surface according to above methods. In any case, it is important to clean the surface to SA 2,5 and 75 microns roughness. If possible dry the surface before applying. If not possible, use Wencon UW products.

For further information on Wencon surface preparation, please contact our Area Sales Managers.

Wheel house aluminium - corrosion

APPLICATION DATA SHEET No. 135

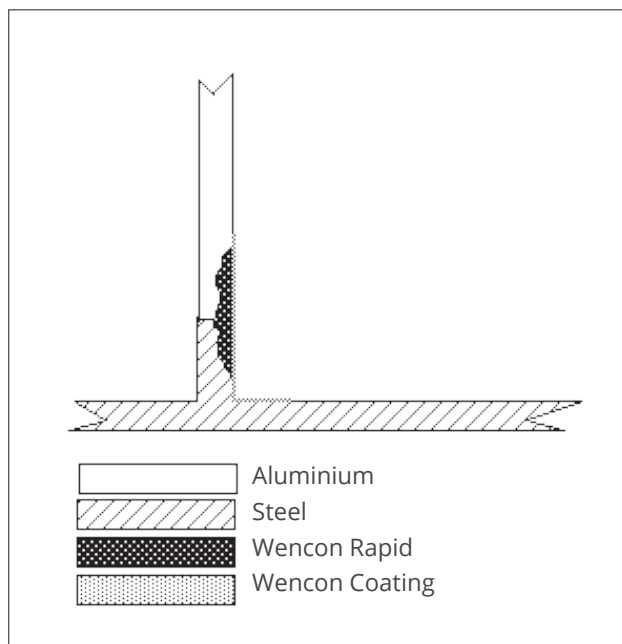

Drawing shows corrosion in the area, where steel and aluminum meet. The corrosion is of bimetallic nature, and is very simple to repair (avoid) with Wencon.

1. Prepare the surface acc. to Wencon surface preparation, next page.
2. Mix and apply a layer of Wencon Cream or Rapid to create an even surface.
3. After semi curing, while the first layer is still a bit tacky, apply the Wencon Coating, white on the whole area in question, and leave it again for semi curing. Apply the final layer, being the Wencon Coating, blue.
4. If the area is subjected to high temperatures or chemical attack, use the Wencon Hi-Temp in stead of the Wencon Coating.

Wencon surface preparation

Choose the relevant surface preparation, depending on the nature of the job.

Surface preparation using dry blasting methods:

Application with Wencon products on a dry surface, at minimum 3°C above dew point.

1. Blast the machine part to SA 2,5 using sharp-edged blasting media, to a roughness of min. 75 microns.
2. Leave the part for sweating out salts in a warm place for at least 12 hours or heat it up to 30 - 40°C (86-104 °F) using gas torches.
3. Blast again to SA 2,5, prior to the application.
4. For parts containing a lot of water and salt, it may be necessary to repeat point 2 and 3, until the surface remains light grey, for at least 2 hours after blasting.
5. For optimal adhesion of Wencon products, always use Wencon Bio Cleaner or Wencon Cleaner prior to application. Follow one of below two methods:
 - 5.1 **Wencon Bio Cleaner**
Wet surface: Apply Wencon Bio Cleaner and let it work for 5-10 min. If necessary use a brush, to make sure the surface is clean. Rinse off with clean water and wipe off with an absorbing cloth.

Dry surface: Apply Wencon Bio Cleaner and let it work for 5-10 min. If necessary use a brush, to make sure the surface is clean. Rinse off with clean water and dry with an absorbing cloth or with compressed air for a completely dry surface. Hereafter any Wencon products can be applied.
 - 5.2 **Wencon Cleaner**
 After surface preparation, apply Wencon Cleaner with a brush and allow the product to evaporate before applying other Wencon products. Wencon Cleaner is non-flammable. Use only in large or well ventilated rooms.

Surface preparation using wet/damp methods:

Water jet the entire surface with water and sand to a standard equal, to SA 2,5 as described above.

If the surface is left wet after surface preparation, is it important to dry out the surface or alternatively use a Wencon UW product.

Surface preparation for emergency/temporary applications:

If above surface preparation methods are not possible, it may be necessary to use one of below methods:

- Blasting
- Grinding
- Needle Gunning

In emergency / temporary applications it may be difficult to prepare the surface according to above methods. In any case, it is important to clean the surface to SA 2,5 and 75 microns roughness. If possible dry the surface before applying. If not possible, use Wencon UW products.

For further information on Wencon surface preparation, please contact our Area Sales Managers.

Index - Chapter 6

American Bureau of Shipping.....	191
DNV-GL Certificate.....	197
RINA Certificate.....	210
ISO9001:2015 Certificate.....	212



CERTIFICATE NUMBER	22-2298636-1-PDA
EFFECTIVE DATE	20-Mar-2024
EXPIRY DATE	29-Aug-2027
ABS TECHNICAL OFFICE	Rotterdam Materials Eng

CERTIFICATE OF Product Design Assessment

This is to certify that a representative of this Bureau did, at the request of

WENCON

located at

15 JYLLANDSVEJ, , BOGENSE, Denmark, DK-5400

assess design plans and data for the below listed product. This assessment is a representation by the Bureau as to the degree of compliance the design exhibits with applicable sections of the Rules. This assessment does not waive unit certification or classification procedures required by ABS Rules for products to be installed in ABS classed vessels or facilities. This certificate, by itself, does not reflect that the product is Type Approved. The scope and limitations of this assessment are detailed on the pages attached to this certificate.

Product: Synthetic Repair Compounds & Resins
Model: See Attachment
Endorsements:
Tier: 2 - PDA Issued

This Product Design Assessment (PDA) Certificate remains valid until 29/Aug/2027 or until the Rules and/or Standards used in the assessment are revised or until there is a design modification warranting design reassessment (whichever occurs first).

Acceptance of product is limited to the "Intended Service" details prescribed in the certificate and as per applicable Rules and Standards.

This Certificate is valid for installation of the listed product on ABS units which exist or are under contract for construction on or previous to the effective date of the ABS Rules and standards applied at the time of PDA issuance. Use of the Product for non-ABS units is subject to agreement between the manufacturer and intended client.

American Bureau Of Shipping

Nikolaos (Nikos Vrellos) Vrellos,Engineer/Consultant

NOTE: This certificate evidences compliance with one or more of the Rules, Guides, standards or other criteria of ABS or a statutory, industrial or manufacturer's standards. It is issued solely for the use of ABS, its committees, its clients or other authorized entities. Any significant changes to the aforementioned product without approval from ABS will result in this certificate becoming null and void. This certificate is governed by ABS Rules 1-1-A3/5.9 Terms and Conditions of the Request for Product Type Approval and Agreement (2010)

WENCON

15 JYLLANDSVEJ

BOGENSE

Denmark DK-5400

Telephone: 45-648-11010

Fax:

Email: wencon@wencon.com

Web: www.wencon.com

Tier: 2 - PDA Issued

Product: Synthetic Repair Compounds & Resins

Model: See Attachment

Endorsements:

Intended Service:

- 1) Repair of and/or protection against deterioration of metals in pumps, valves, filters, pipes, heating coils, tanks, bulk heads, coolers, rudder stocks, propeller shafts, etc.;
- 2) For creating fixture and preventing future corrosion in the seats for rudder stock bushings, rudder heel bushings, rudder cone assemblies, rudder pintle bushings, rudder pintle cones, stern tubes, and the like.

Description:

Wencon Repair and Protection System

Rating:

See attachment "Model & Rating_WENCON_22-2298636-1-PDA"

Service Restriction:

Unit Certification is not required for this product. If the manufacturer or purchaser requests an ABS Certificate for compliance with a specification or standard, the specification or standard, including inspection standards and tolerances, must be clearly defined.

Repairs on piping are not to be commenced without prior consultation and agreement with the ABS Survey.

Comments:

The Manufacturer has provided a declaration about the control of, or the lack of Asbestos in this product.

- 1) Repair procedures including surface preparation and application are to be carried out in accordance with the manufacturer's specifications and procedures and as per Wencon Manual "Repair of deteriorated machine parts" (latest edition available at www.wencon.com).
- 2) Repairs on structural items and pressure containing systems, the Surveyor is to be contacted prior to commencing repair, in order to obtain the Surveyor's acceptance for the specific application.
- 3) The Repair System may be applied to both metallic and plastic/ composite pressure containment systems.
- 4) The following limitations apply to the repair of pressure containing systems using Wencon Pipe Tape:
 - a) Maximum temperature 120 Deg. C.
 - b) Maximum pressure when used with Wencon Putty 50bar.
 - c) Maximum pressure when used without Wencon Putty 10bar.
 - d) The use of these products is not permitted on any pressure part in containing a toxic or flammable liquid or gas.

ABS expressly disclaims all warranties with respect to the coating and the design assessment, including warranties of merchantability and fitness for a particular purpose. Successful coating is dependent on coating properties (some of which may not have been addressed in the approval standard), proper application (including surface prep, application, curing environment, etc.) and proper maintenance. These aspects are beyond the scope of this approval.

Notes/Drawing/Documentation:

Drawing No. CS Hi-Build, Product Info & Application Instructions, Revision: 1.3, Pages: 1

Drawing No. Chemical Resistance - CS Hi-Build, Chemical Resistance Chart, Revision: -, Pages: 1

Drawing No. Declaration of Conformity DPA 22-2298636, Client Declaration, Revision: -, Pages: 1

Drawing No. Wencon CS HI-Build - Component A_DK_EN, Safety Data Sheet, Revision: 1.0, Pages: 1

Drawing No. Wencon CS HI-Build - Component B_DK_EN, Safety Data Sheet, Revision: 1.0, Pages: 1

Terms of Validity:

This Product Design Assessment (PDA) Certificate remains valid until 29/Aug/2027 or until the Rules and/or Standards used in the assessment are revised or until there is a design modification warranting design reassessment

WENCON

15 JYLLANDSVEJ

BOGENSE

Denmark DK-5400

Telephone: 45-648-11010

Fax:

Email: wencon@wencon.com

Web: www.wencon.com

Tier: 2 - PDA Issued

(whichever occurs first).

Acceptance of product is limited to the "Intended Service" details prescribed in the certificate and as per applicable Rules and Standards.

This Certificate is valid for installation of the listed product on ABS units which exist or are under contract for construction on or previous to the effective date of the ABS Rules and standards applied at the time of PDA issuance. Use of the Product for non-ABS units is subject to agreement between the manufacturer and intended client.

STANDARDS

ABS Rules:

2024 ABS Rules for Conditions of Classification - Ships, Part 1A-1-4/7.7, 1A-1-A3, 1A-1-A4

2024 ABS Rules for Conditions of Classification - Offshore Units and Structures, Part 1B-1-4/9.7, 1B-1-A2, 1B-1-A3

2024 ABS Rules for Conditions of Classification - Light and High-Speed Craft, Part 1C-1-4/11.9, 1C-1-A2, 1C-1-A3

National:

NA

International:

NA

Government:

NA

EUMED:

NA

OTHERS:

Manufacturer's Standards

WENCON (WCN: 021923)
PDA no.: 22-2298636-1-PDA
Model: Current Document
Issuance Date: 30-AUG-2022
Expiration Date: 29-AUG-2027

Model Name	Product Type	Ratings
Wencon Cream	Two part Epoxy based compound	Temperature Resistance Corrosion: 60°C, Light load: 120°C, As filler: 250°C Chemical Resistance The compound is resistant to oil, water, saltwater and most diluted acids and alkalis as well as a range of solvents.
Wencon Rapid	Two part Epoxy based compound	Temperature Resistance Corrosion: 60°C, Light load: 120°C, As filler: 250°C Chemical Resistance The compound is resistant to oil, water, saltwater and most diluted acids and alkalis as well as a range of solvents.
Wencon Coating	Two part Epoxy based compound	Temperature Resistance Corrosion: 60°C, Light load: 120°C, As filler: 250°C Chemical Resistance The compound is resistant to oil, water, saltwater and most diluted acids and a range of solvents.
Wencon HiTemp	Two part Epoxy based compound	Temperature Resistance Corrosion: 160°C, Light load: 220°C, As filler: 300°C Chemical Resistance The compound is resistant to oil, water, saltwater and a wide range acids and alkalis as well as a range of solvents.
Wencon Putty	Two part Epoxy based compound	Temperature Resistance Corrosion: 60°C, Light load: 120°C, As filler: 250°C Chemical Resistance The compound is resistant to oil, water, saltwater and most diluted acids and alkalis as well as a range of solvents.
Wencon UW Cream	Two part Epoxy based compound (for wet surfaces or under water)	Temperature resistance Corrosion and heavy load: 60°C, Light load or no load: 100°C, As filler: 160°C Chemical resistance After curing, the Wencon UW Cream will be resistant to oil, water, saltwater, most diluted acids and a range of solvents.
Wencon UW Coating	Two part Epoxy based compound (for wet surfaces or under water)	Temperature resistance Corrosion and heavy load: 60°C, Light load or no load: 100°C, As filler: 160°C Chemical resistance After curing, the Wencon UW Coating will be resistant to oil, water, saltwater, most diluted acids and a range of solvents.
Wencon UW Putty	Two part Epoxy based compound (for under water applications)	Temperature resistance Corrosion and heavy load: 60°C, Light load or no load: 100°C, As filler: 160°C Chemical resistance After curing, the Wencon UW Coating will be resistant to oil, water, saltwater, most diluted acids and a range of solvents.

WENCON (WCN: 021923)
PDA no.: 22-2298636-1-PDA
Model: Current Document
Issuance Date: 30-AUG-2022
Expiration Date: 29-AUG-2027

Model Name	Product Type	Ratings
Wencon CS Hi-Build	Two part Epoxy based compound	Temperature Resistance Corrosion: 160°C, Light load: 210°C. Chemical Resistance The compound is resistant to aqueous solutions, and several acids, alkalis, and caustics.
Wencon Ceramic Coating	Two part Epoxy based compound (high abrasive resistance)	Temp, erature Resistance Corrosion: 60°C, Light load: 120°C, As filler: 300°C Chemical Resistance The compound is resistant to oil, water, saltwater and most diluted acids and alkalis as well as a range of solvents.
Wencon Ceramic Cream	Two part Epoxy based compound (high abrasive resistance)	Temperature Resistance Corrosion: 60°C, Light load: 120°C, As filler: 300°C Chemical Resistance The compound is resistant to oil, water, saltwater and most diluted acids and alkalis as well as a range of solvents.
Wencon PipeTape	Glass fibre reinforced with a polyurethane resin matrix	Temperature Resistance Continuous: 120°C Pressure Resistance Pipe pressure with Wencon Putty: 50 Bar Pipe pressure without Wencon Putty: 10 Bar Chemical Resistance The compound is resistant to oil, water, saltwater and diluted acids and alkalis.
Wencon Exhaust	Silica based compound	Temperature Resistance Up to: 1300°C Chemical Resistance The compound is resistant to oil, water, saltwater and most diluted acids and alkalis as well as a range of solvents.



TYPE APPROVAL CERTIFICATE

Certificate no.:
TAK00001K2
Revision No:
2

This is to certify:

that the **Polymer Repair System**

with type designation(s)

Wencon Standard Products:

- Wencon Coating,
- Wencon Cream,
- Wencon Rapid,
- Wencon Putty

issued to

Wencon ApS
Bogense, Syddanmark, Denmark

is found to comply with

DNV rules for classification – Ships

Application:

Epoxy-based compounds suitable for repairs, maintenance and preventive maintenance tasks of steel, epoxy and epoxy compatible composites. Each repair shall be carried out in accordance with Manufacturer's instructions, approved by DNV, and under surveillance of DNV, when deemed applicable.

Product(s) approved by this certificate is/are accepted for installation on all vessels classed by DNV.

Issued at **Hamburg** on **2024-05-01**

This Certificate is valid until **2029-04-30**.

DNV local unit: **Denmark CMC**

Approval Engineer: **Gisle Hersvik**

for **DNV**



Digitally Signed By:
Christian Wildhagen
Location: DNV Hamburg,
Germany

This Certificate is subject to terms and conditions overleaf. Any significant change in design or construction may render this Certificate invalid. The validity date relates to the Type Approval Certificate and not to the approval of equipment/systems installed.

LEGAL DISCLAIMER: Unless otherwise stated in the applicable contract with the holder of this document, or following from mandatory law, the liability of DNV AS, its parent companies and their subsidiaries as well as their officers, directors and employees ("DNV") arising from or in connection with the services rendered for the purpose of the issuance of this document or reliance thereon, whether in contract or in tort (including negligence), shall be limited to direct losses and under any circumstance be limited to 300,000 USD.



Form code: TA 251

Revision: 2023-09

www.dnv.com

Page 1 of 3

Product description

Wencon Standard Products:

- o **Wencon Coating**
- o **Wencon Cream**
- o **Wencon Rapid**
- o **Wencon Putty**

The listed products are commonly used for Temporary and Permanent Maintenance tasks, but also proves useful for a range of Emergency Repairs in Dry surroundings and environments.

The products are not intended for tasks where Wet, Hot or Harsh Abrasion surroundings and environment is a part of the task.

Application/Limitation

Epoxy-based compounds suitable for repairs, maintenance and preventive maintenance tasks of steel, epoxy and epoxy compatible composites.

- Repair and/or protection against bimetallic corrosion and erosion/corrosion attacks in pumps, valves, filters, pipes, tanks, coolers, etc.
- Creating fixture and preventing future corrosion in the seats for rudder stock bushing, rudder heel bushing, rudder cone assembly, rudder pintle bushing, rudder pintle cone, stern tube, etc.
- Composite wrap for piping lines transferring oil, fresh & sea water, diluted acids & solvents, etc.

Repair activities for components which affect or might affect the Class of the ship must be reported in advance to DNV.

Installation only in accordance with DNV Rules and Manufacturer's work instructions.

For limitations as to environmental conditions and exposure to chemicals, confer manufacturer's instructions.

The maximum working temperature shall be in accordance with Manufacturer's instructions / information in the relevant technical data sheet.

An adequate curing shall be proven by a Shore D test. The hardness shall be in accordance with Manufacturer's instructions / information in the relevant technical data sheet.

The lifetime and the performance of a repair is, apart from the procedure of application of the system, dependent on the service environment, imposed mechanical loads and deformations and may vary significantly from case to case. A careful assessment of the expected reliability of the repair shall always be carried out by the DNV surveyor and the manufacturer's representative with due regard to the service requirements and the requirements to the reliability of the component to be repaired.

The system has limited or no resistance to exposure to fire. Requirements to the performance of the repair under fire shall be carefully evaluated by the DNV surveyor and the manufacturer's representative.

Any significant changes in design and/or quality of the material will render the approval invalid.

Planning and execution of repair

Each repair shall be carried out in close co-operation with the DNV surveyor:

- The surveyor shall be informed about and participate in (if required by the surveyor) the planning of the repair.
- When required by the surveyor, the surface preparation shall be witnessed and/or the finally prepared surfaces shall be made available for inspection and approved by the surveyor.
- When required by the surveyor, the application of the system and curing shall be witnessed by the same.
- When required by the surveyor, other operations shall be witnessed and approved by the surveyor.
- When required by the surveyor, the final condition of the repair shall be approved by the same.

Type Approval documentation

1. [Assessment Report from DNV Fredericia of 2024-02-19](#)
2. [Application for Type Approval of 2024-01-08](#)
3. [ISO 9001-certificate and ISO 14001-certificate](#)
4. [Application for Type Approval of 2021-12-09](#)
5. [Assessment Report from DNV GL Fredericia of 2019-04-29](#)



Job ID: **262.1-030415-7**
Certificate no.: **TAK00001K2**
Revision No: **2**

6. Application for Type Approval of 2019-04-15.
7. TDS
8. MSDS
9. Experiences

Tests carried out

Type Testing carried out in accordance with **Type Approval documentation**.

Marking of product

All components of the system are to be marked with manufacturer's name, type designation, date of fabrication and shelf life or expiry date. In addition, the following documentation shall be submitted with the product:

- Product specification.
- Specification of range of application and limitations.
- Detailed procedures for surface preparation.
- Detailed procedures for application.
- Detailed procedures for curing.
- Hazards and precautions to be taken with regard to occupational safety.

The marking is to be carried out in such a way that it is visible, legible and indelible. The marking of product is to enable traceability to the DNV Type Approval Certificate.

Periodical assessment

The scope of the Periodical Assessment is to verify that the conditions stipulated for the Type Approval is complied with and that no alterations are made to the product design or choice of materials.

Periodical assessments (for Certificate Retention / Certificate Renewal) shall be performed according to DNV-CP-0338.

This certificate is only valid if required Periodical assessments are carried out with satisfactory results. To check the validity of this certificate, please look it up in <https://approvalfinder.dnv.com>

END OF CERTIFICATE



TYPE APPROVAL CERTIFICATE

Certificate no.:
TAK00001K3
Revision No:
2

This is to certify:
that the Polymer Repair System

with type designation(s)
Wencon Under Water Products:
-Wencon UW Coating,
-Wencon UW Cream,
-Wencon UW Putty,
-Wencon Pipe Tape

issued to
Wencon ApS
Bogense, Syddanmark, Denmark

is found to comply with
DNV rules for classification – Ships

Application:

Epoxy-based compounds suitable for repairs, maintenance and preventive maintenance tasks of steel, epoxy and epoxy compatible composites. Each repair shall be carried out in accordance with Manufacturer's instructions, approved by DNV, and under surveillance of DNV, when deemed applicable.

Product(s) approved by this certificate is/are accepted for installation on all vessels classed by DNV.

Issued at **Hamburg** on **2024-05-01**

This Certificate is valid until **2029-04-30**.

DNV local unit: **Denmark CMC**

Approval Engineer: **Gisle Hersvik**

for **DNV**



Digitally Signed By:
Christian Wildhagen
Location: DNV Hamburg,
Germany

This Certificate is subject to terms and conditions overleaf. Any significant change in design or construction may render this Certificate invalid. The validity date relates to the Type Approval Certificate and not to the approval of equipment/systems installed.

LEGAL DISCLAIMER: Unless otherwise stated in the applicable contract with the holder of this document, or following from mandatory law, the liability of DNV AS, its parent companies and their subsidiaries as well as their officers, directors and employees ("DNV") arising from or in connection with the services rendered for the purpose of the issuance of this document or reliance thereon, whether in contract or in tort (including negligence), shall be limited to direct losses and under any circumstance be limited to 300,000 USD.



Form code: TA 251

Revision: 2023-09

www.dnv.com

Page 1 of 3

Product description

Wencon Under Water Products:

- o **Wencon UW Coating**
- o **Wencon UW Cream**
- o **Wencon UW Putty**
- o **Wencon Pipe Tape**

The listed products are commonly used targeting on Temporary Solutions and Emergency Repairs in wet surroundings and environments, because its excellent adhesion under water and on high moisture surfaces.

Application/Limitation

Epoxy-based compounds suitable for repairs, maintenance and preventive maintenance tasks of steel, epoxy and epoxy compatible composites.

- Repair and/or protection against bimetallic corrosion and erosion/corrosion attacks in pumps, valves, filters, pipes, tanks, coolers, etc.
- Creating fixture and preventing future corrosion in the seats for rudder stock bushing, rudder heel bushing, rudder cone assembly, rudder pintle bushing, rudder pintle cone, stern tube, etc.
- Composite wrap for piping lines transferring oil, fresh & sea water, diluted acids & solvents, etc.

Repair activities for components which affect or might affect the Class of the ship must be reported in advance to DNV.

Installation only in accordance with DNV Rules and Manufacturer's work instructions.

For limitations as to environmental conditions and exposure to chemicals, confer manufacturer's instructions.

The maximum working temperature shall be in accordance with Manufacturer's instructions / information in the relevant technical data sheet.

An adequate curing shall be proven by a Shore D test. The hardness shall be in accordance with Manufacturer's instructions / information in the relevant technical data sheet.

The lifetime and the performance of a repair is, apart from the procedure of application of the system, dependent on the service environment, imposed mechanical loads and deformations and may vary significantly from case to case. A careful assessment of the expected reliability of the repair shall always be carried out by the DNV surveyor and the manufacturer's representative with due regard to the service requirements and the requirements to the reliability of the component to be repaired.

The system has limited or no resistance to exposure to fire. Requirements to the performance of the repair under fire shall be carefully evaluated by the DNV surveyor and the manufacturer's representative.

Any significant changes in design and/or quality of the material will render the approval invalid.

Planning and execution of repair

Each repair shall be carried out in close co-operation with the DNV surveyor:

- The surveyor shall be informed about and participate in (if required by the surveyor) the planning of the repair.
- When required by the surveyor, the surface preparation shall be witnessed and/or the finally prepared surfaces shall be made available for inspection and approved by the surveyor.
- When required by the surveyor, the application of the system and curing shall be witnessed by the same.
- When required by the surveyor, other operations shall be witnessed and approved by the surveyor.
- When required by the surveyor, the final condition of the repair shall be approved by the same.

Type Approval documentation

1. **Assessment Report from DNV Fredericia of 2024-02-19**
2. **Application for Type Approval of 2024-01-08**
3. **ISO 9001-certificate and ISO 14001-certificate**
4. **Application for Type Approval of 2021-12-09.**
5. **Assessment Report from DNV GL Fredericia of 2019-04-29.**
6. **Application for Type Approval of 2019-04-15.**



Job ID: **262.1-030415-6**
Certificate no.: **TAK00001K3**
Revision No: **2**

- 7. TDS
- 8. MSDS
- 9. Experiences

Tests carried out

Type Testing carried out in accordance with **Type Approval documentation**.

Marking of product

All components of the system are to be marked with manufacturer's name, type designation, date of fabrication and shelf life or expiry date. In addition, the following documentation shall be submitted with the product:

- Product specification.
- Specification of range of application and limitations.
- Detailed procedures for surface preparation.
- Detailed procedures for application.
- Detailed procedures for curing.
- Hazards and precautions to be taken with regard to occupational safety.

The marking is to be carried out in such a way that it is visible, legible and indelible. The marking of product is to enable traceability to the DNV Type Approval Certificate.

Periodical assessment

The scope of the Periodical Assessment is to verify that the conditions stipulated for the Type Approval is complied with and that no alterations are made to the product design or choice of materials.

Periodical assessments (for Certificate Retention / Certificate Renewal) shall be performed according to DNV-CP-0338.

This certificate is only valid if required Periodical assessments are carried out with satisfactory results. To check the validity of this certificate, please look it up in <https://approvalfinder.dnv.com>

END OF CERTIFICATE



TYPE APPROVAL CERTIFICATE

Certificate no.:
TAK00001K4
Revision No:
2

This is to certify:

that the **Polymer Repair System**

with type designation(s)

Wencon High Temperature Products:

-Wencon Exhaust Repair,

-Wencon Hi - Temp

issued to

Wencon ApS

Bogense, Syddanmark, Denmark

is found to comply with

DNV rules for classification – Ships

Application:

Epoxy-based compounds suitable for repairs, maintenance and preventive maintenance tasks of steel, epoxy and epoxy compatible composites. Each repair shall be carried out in accordance with Manufacturer's instructions, approved by DNV, and under surveillance of DNV, when deemed applicable.

Product(s) approved by this certificate is/are accepted for installation on all vessels classed by DNV.

Issued at **Hamburg** on **2024-05-01**

This Certificate is valid until **2029-04-30**.

DNV local unit: **Denmark CMC**

Approval Engineer: **Gisle Hersvik**

for **DNV**



Digitally Signed By:
Christian Wildhagen
Location: DNV Hamburg,
Germany

This Certificate is subject to terms and conditions overleaf. Any significant change in design or construction may render this Certificate invalid. The validity date relates to the Type Approval Certificate and not to the approval of equipment/systems installed.

LEGAL DISCLAIMER: Unless otherwise stated in the applicable contract with the holder of this document, or following from mandatory law, the liability of DNV AS, its parent companies and their subsidiaries as well as their officers, directors and employees ("DNV") arising from or in connection with the services rendered for the purpose of the issuance of this document or reliance thereon, whether in contract or in tort (including negligence), shall be limited to direct losses and under any circumstance be limited to 300,000 USD.



Form code: TA 251

Revision: 2023-09

www.dnv.com

Page 1 of 3

Product description

Wencon High Temperature Products:

- o Wencon Exhaust Repair
- o Wencon Hi – Temp

The listed products are suitable for applications where there is a demand for resistance to warm environments like Hot Oil and Steam such as Heating Coils, Boilers and Exhaust Systems.

Application/Limitation

Epoxy-based compounds suitable for repairs, maintenance and preventive maintenance tasks of steel, epoxy and epoxy compatible composites.

- Repair and/or protection against bimetallic corrosion and erosion/corrosion attacks in pumps, valves, filters, pipes, tanks, coolers, etc.
- Creating fixture and preventing future corrosion in the seats for rudder stock bushing, rudder heel bushing, rudder cone assembly, rudder pintle bushing, rudder pintle cone, stern tube, etc.
- Composite wrap for piping lines transferring oil, fresh & sea water, diluted acids & solvents, etc.

Repair activities for components which affect or might affect the Class of the ship must be reported in advance to DNV.

Installation only in accordance with DNV Rules and Manufacturer's work instructions.

For limitations as to environmental conditions and exposure to chemicals, confer manufacturer's instructions.

The maximum working temperature shall be in accordance with Manufacturer's instructions / information in the relevant technical data sheet.

An adequate curing shall be proven by a Shore D test. The hardness shall be in accordance with Manufacturer's instructions / information in the relevant technical data sheet.

The lifetime and the performance of a repair is, apart from the procedure of application of the system, dependent on the service environment, imposed mechanical loads and deformations and may vary significantly from case to case. A careful assessment of the expected reliability of the repair shall always be carried out by the DNV surveyor and the manufacturer's representative with due regard to the service requirements and the requirements to the reliability of the component to be repaired.

The system has limited or no resistance to exposure to fire. Requirements to the performance of the repair under fire shall be carefully evaluated by the DNV surveyor and the manufacturer's representative.

Any significant changes in design and/or quality of the material will render the approval invalid.

Planning and execution of repair

Each repair shall be carried out in close co-operation with the DNV surveyor:

- The surveyor shall be informed about and participate in (if required by the surveyor) the planning of the repair.
- When required by the surveyor, the surface preparation shall be witnessed and/or the finally prepared surfaces shall be made available for inspection and approved by the surveyor.
- When required by the surveyor, the application of the system and curing shall be witnessed by the same.
- When required by the surveyor, other operations shall be witnessed and approved by the surveyor.
- When required by the surveyor, the final condition of the repair shall be approved by the same.

Type Approval documentation

1. Assessment Report from DNV Fredericia of 2024-02-19
2. Application for Type Approval of 2024-01-08
3. ISO 9001-certificate and ISO 14001-certificate
4. Application for Type Approval of 2021-12-09.
5. Assessment Report from DNV GL Fredericia of 2019-04-29.
6. Application for Type Approval of 2019-04-15.
7. TDS
8. MSDS
9. Experiences



Job ID: **262.1-030415-8**
Certificate no.: **TAK00001K4**
Revision No: **2**

Tests carried out

Type Testing carried out in accordance with **Type Approval documentation**.

Marking of product

All components of the system are to be marked with manufacturer's name, type designation, date of fabrication and shelf life or expiry date. In addition, the following documentation shall be submitted with the product:

- Product specification.
- Specification of range of application and limitations.
- Detailed procedures for surface preparation.
- Detailed procedures for application.
- Detailed procedures for curing.
- Hazards and precautions to be taken with regard to occupational safety.

The marking is to be carried out in such a way that it is visible, legible and indelible. The marking of product is to enable traceability to the DNV Type Approval Certificate.

Periodical assessment

The scope of the Periodical Assessment is to verify that the conditions stipulated for the Type Approval is complied with and that no alterations are made to the product design or choice of materials.

Periodical assessments (for Certificate Retention / Certificate Renewal) shall be performed according to DNV-CP-0338.

This certificate is only valid if required Periodical assessments are carried out with satisfactory results. To check the validity of this certificate, please look it up in <https://approvalfinder.dnv.com>

END OF CERTIFICATE



TYPE APPROVAL CERTIFICATE

Certificate no.:
TAK00001K5
Revision No:
2

This is to certify:

that the **Polymer Repair System**

with type designation(s)

Wencon Abrasion & Heat Resistance Products:

- Wencon Ceramic Coating,
- Wencon Ceramic Cream

issued to

Wencon ApS

Bogense, Syddanmark, Denmark

is found to comply with

DNV rules for classification – Ships

Application:

Epoxy-based compounds suitable for repairs, maintenance and preventive maintenance tasks of steel, epoxy and epoxy compatible composites. Each repair shall be carried out in accordance with Manufacturer's instructions, approved by DNV, and under surveillance of DNV, when deemed applicable.

Product(s) approved by this certificate is/are accepted for installation on all vessels classed by DNV.

Issued at **Hamburg** on **2024-05-01**

This Certificate is valid until **2029-04-30**.

DNV local unit: **Denmark CMC**

Approval Engineer: **Gisle Hersvik**

for **DNV**



Digitally Signed By:
Christian Wildhagen
Location: DNV Hamburg,
Germany

This Certificate is subject to terms and conditions overleaf. Any significant change in design or construction may render this Certificate invalid. The validity date relates to the Type Approval Certificate and not to the approval of equipment/systems installed.

LEGAL DISCLAIMER: Unless otherwise stated in the applicable contract with the holder of this document, or following from mandatory law, the liability of DNV AS, its parent companies and their subsidiaries as well as their officers, directors and employees ("DNV") arising from or in connection with the services rendered for the purpose of the issuance of this document or reliance thereon, whether in contract or in tort (including negligence), shall be limited to direct losses and under any circumstance be limited to 300,000 USD.



Form code: TA 251

Revision: 2023-09

www.dnv.com

Page 1 of 3

Product description

Wencon Abrasion & Heat Resistance Products:

- o **Wencon Ceramic Coating**
- o **Wencon Ceramic Cream**

The listed products are characterized by being resistant to both abrasion and heat and is therefore preferred in harsh environments where there is both a requirement for Heat Resistance and Abrasion Resistance.

Application/Limitation

Epoxy-based compounds suitable for repairs, maintenance and preventive maintenance tasks of steel, epoxy and epoxy compatible composites.

- Repair and/or protection against bimetallic corrosion and erosion/corrosion attacks in pumps, valves, filters, pipes, tanks, coolers, etc.
- Creating fixture and preventing future corrosion in the seats for rudder stock bushing, rudder heel bushing, rudder cone assembly, rudder pintle bushing, rudder pintle cone, stern tube, etc.
- Composite wrap for piping lines transferring oil, fresh & sea water, diluted acids & solvents, etc.

Repair activities for components which affect or might affect the Class of the ship must be reported in advance to DNV.

Installation only in accordance with DNV Rules and Manufacturer's work instructions.

For limitations as to environmental conditions and exposure to chemicals, confer manufacturer's instructions.

The maximum working temperature shall be in accordance with Manufacturer's instructions / information in the relevant technical data sheet.

An adequate curing shall be proven by a Shore D test. The hardness shall be in accordance with Manufacturer's instructions / information in the relevant technical data sheet.

The lifetime and the performance of a repair is, apart from the procedure of application of the system, dependent on the service environment, imposed mechanical loads and deformations and may vary significantly from case to case. A careful assessment of the expected reliability of the repair shall always be carried out by the DNV surveyor and the manufacturer's representative with due regard to the service requirements and the requirements to the reliability of the component to be repaired.

The system has limited or no resistance to exposure to fire. Requirements to the performance of the repair under fire shall be carefully evaluated by the DNV surveyor and the manufacturer's representative.

Any significant changes in design and/or quality of the material will render the approval invalid.

Planning and execution of repair

Each repair shall be carried out in close co-operation with the DNV surveyor:

- The surveyor shall be informed about and participate in (if required by the surveyor) the planning of the repair.
- When required by the surveyor, the surface preparation shall be witnessed and/or the finally prepared surfaces shall be made available for inspection and approved by the surveyor.
- When required by the surveyor, the application of the system and curing shall be witnessed by the same.
- When required by the surveyor, other operations shall be witnessed and approved by the surveyor.
- When required by the surveyor, the final condition of the repair shall be approved by the same.

Type Approval documentation

1. [Assessment Report from DNV Fredericia of 2024-02-19](#)
2. [Application for Type Approval of 2024-01-08](#)
3. [ISO 9001-certificate and ISO 14001-certificate](#)
4. [Application for Type Approval of 2021-12-09.](#)
5. [Assessment Report from DNV GL Fredericia of 2019-04-29.](#)
6. [Application for Type Approval of 2019-04-15.](#)
7. [TDS](#)
8. [MSDS](#)
9. [Experiences](#)

Tests carried out

Type Testing carried out in accordance with **Type Approval documentation**.

Marking of product

All components of the system are to be marked with manufacturer's name, type designation, date of fabrication and shelf life or expiry date. In addition, the following documentation shall be submitted with the product:

- Product specification.
- Specification of range of application and limitations.
- Detailed procedures for surface preparation.
- Detailed procedures for application.
- Detailed procedures for curing.
- Hazards and precautions to be taken with regard to occupational safety.

The marking is to be carried out in such a way that it is visible, legible and indelible. The marking of product is to enable traceability to the DNV Type Approval Certificate.

Periodical assessment

The scope of the Periodical Assessment is to verify that the conditions stipulated for the Type Approval is complied with and that no alterations are made to the product design or choice of materials.

Periodical assessments (for Certificate Retention / Certificate Renewal) shall be performed according to DNV-CP-0338.

This certificate is only valid if required Periodical assessments are carried out with satisfactory results. To check the validity of this certificate, please look it up in <https://approvalfinder.dnv.com>

END OF CERTIFICATE



TYPE APPROVAL CERTIFICATE
No. **MAC077224XG**

This is to certify that the product identified below is in compliance with the regulations herewith specified.

<i>Description</i>	Surface Protection and Cold Repair Products
<i>Type</i>	BASIC PRODUCTS: WENCON CREAM, RAPID, COATING, HI-TEMP, PUTTY, PIPE TAPE, EXHAUST REPAIR UNIQUE PRODUCTS: WENCON UW CREAM, UW COATING, UW PUTTY, CERAMIC CREAM, CERAMIC COATING CS HI-Build
<i>Applicant</i>	Wencon ApS Jyllandsvej 15 5400 Bogense DENMARK
<i>Manufacturer</i>	Wencon ApS
<i>Place of manufacture</i>	Jyllandsvej 15 5400 Bogense DENMARK
<i>Reference standards</i>	RINA Rules for testing, certification and acceptance of marine materials and equipment, Ch. 3, Par. 7

Issued in **HAMBURG** on **June 13, 2024**. *This Certificate is valid until* **June 12, 2029**

RINA Services S.p.A.
Giuseppe Russo

This certificate consists of this page and 1 enclosure.

TYPE APPROVAL CERTIFICATE

No. **MAC077224XG**

Enclosure - Page 1 of 1

BASIC PRODUCTS: WENCON CREAM, RAPID, COATING, HI-TEMP, PUTTY, PIPE TAPE, EXHAUST REPAIR

UNIQUE PRODUCTS: WENCON UW CREAM, UW COATING, UW PUTTY, CERAMIC CREAM, CERAMIC COATING

CS HI-Build

Reference documents:

Documents submitted by Wencon ApS and filed for information under RINA dwg no. HMMC-13225.

Technical characteristics:

WENCON products consist of a range of one and two-component epoxy, polyurethane and silica based products.

Resistant products to oil, water, sea water and some other products (as diluted acids, solvents, etc.) manufactured by WENCON ApS.

Generic product properties as per RINA dwg no. HMMC-13225

Fields of application:

This product may be used on board of ships and other units classed by the RINA for :

- Repair and/or protection against bimetallic corrosion and erosion/corrosion attacks in pumps, valves, filters, pipes, tanks, coolers, etc.
- Creating fixture and preventing future corrosion in the seats for rudder stock bushing, rudder heel bushing, rudder cone assembly, rudder pintle bushing, rudder pintle cone, stern tube, etc.
- Composite wrap for piping lines transferring oil, fresh & sea water, diluted acids & solvents, etc.

Acceptance conditions:

- Repair procedures including surface preparation and application are to be carried out in accordance with the manufacturer's specifications and procedures and manuals available at www.wencon.com.

- The local RINA Surveyor is to be contacted prior to commencing any repair, in order to obtain an acceptance for the particular application.

- This product as a temporary or permanent repair measure will be accepted by the RINA attending Surveyor, if the repaired part of machinery or piping system passes all the tests required by the RINA Rules.

- This product is not allowed for components in rubbing or cycling contact with other components where temperature exceeds 90°C.

- All tests are to be carried out as per a relevant BSI, DIN, ASTM method at the Manufacturer sites.

- The production sites are to bear the RINA Production Control Certificates.

Remarks:

- This product is to be marked with the following description:

name of the Supplier, product designation, packing date, storage condition.

- Each delivery is to be provided with a Certificate of Conformity.

HAMBURG June 13, 2024

RINA Services S.p.A.
Via Corsica, 12 - 16128 Genova
Tel +39 010 53851
Fax +39 010 5351000





BUREAU
VERITAS

Bureau Veritas Certification

Wencon ApS

Jyllandsvej 15, 5400 Bogense, Denmark

Bureau Veritas Certification Denmark A/S certifies that the Management System of the above organization has been audited and found to be in accordance with the requirements of the management system standards detailed below:

Standard

ISO 9001:2015

Scope of certification

Sales and delivery of solutions for repair and life extension of new, corroded and damaged metal parts.

Original Cycle Start Date:	21-12-2016
Expiry date of previous cycle:	20-12-2025
Certification/Recertification Audit date:	NA
Certification/Recertification Cycle Start Date:	21-12-2025
Subject to the continued satisfactory operation of the organization's Management System, this certificate expires on:	20-12-2028

Certificate No.: **DK019852**

Version: 1

Issue date: **04-12-2025**



Certification Body Address: Bureau Veritas Certification Denmark A/S, Oldenborggade 25-31, 7000 Fredericia, Denmark

Further clarifications regarding the scope and validity of this certificate, and the applicability of the management system requirements, please call: (+45) 77 311 000



Wencon physical properties - S.I metrics system



	Wencon Cream	Wencon Rapid	Wencon Coating white+blue	Wencon Hi-Temp yellow+green	Wencon Putty	Wencon Pipe Tape	Wencon Exhaust Repair kit	Wencon UW Cream	Wencon UW Coating orange+brown	Wencon UW Coating LV	Wencon UW Putty	Wencon Ceramic Cream	Wencon Ceramic grey+green
Max. Temperature	+60 - +250°C	+60 - +250°C	+60 - +250°C	+160 - +300°C	+60 - +250°C	+120°C	Up to +1000°C (1832°F)	+60 - +160°C	+60 - +160°C	+60 - +160°C	+60 - +95°C	+200 - +300°C	+220 - +320°C
Consistency	paste	paste	fluid	fluid	putty		fluid	paste	fluid	fluid	putty	paste	fluid
Mixing ratio vol.	1:1	1:1	1:2	1:2	-		No mixing.	1:2	1:2	2:1	1:1	1:2	1:2
Apply with	spatula	spatula	spatula/brush	spatula/brush	hand/spatula	hand	see prod. info.	spatula	spatula/brush	Spray	hand/spatula	spatula	spatula/brush
Potlife at 20 C.	30-60 min. Mixed in small amounts	10-20 min. mixed in small amounts	20-30 min. mixed in small amounts	20-40 min. mixed in small amounts	3-6 min. mixed in small amounts	4-6 min.		25-30 min. mixed in small amounts	25-35 min. mixed in small amounts	15-20 min. in nozzle	25 minutes	30-40 min. mixed in small amounts	20-30 min. mixed in small amounts
Curing time	10 - 15 hrs	40 - 90 min.	10 - 15 hrs	10 - 24 hrs	10 - 20 min.	10 - 30 min.	Initial curing 3-4 hrs	10 - 18 hrs	10 - 18 hrs	10-18 hrs.	10 - 18 hrs	10 - 15 hrs	10 - 15 hrs
Machinability	yes	yes	yes	yes	yes		yes	yes	yes	yes	yes	yes	yes
Hardness shore D	75	81	80	82	85	N/A	N/A	79	79	80	76	80	81
Tensile strength Rcrack	14,30 N/mm ²	9,20 N/mm ²	12,90 N/mm ²	13,80 N/mm ²	4,60 N/mm ²	172 N/mm ²	N/A	35,80 N/mm ²	37,50 N/mm ²	37,00 N/mm ²	17,6 N/mm ²	25,80 N/mm ²	25,40 N/mm ²
Compressive strength Rcrack	58 N/mm ²	112 N/mm ²	95 N/mm ²	96 N/mm ²	35,14 N/mm ²	180 N/mm ²	N/A	134 N/mm ²	133 N/mm ²	130 N/mm ²	25,30 N/mm ²	65,10 N/mm ²	124 N/mm ²
Compr.strength modulus of elasticity	1.689 N/mm ²	2.891 N/mm ²	2.199 N/mm ²	4.284 N/mm ²	NA		N/A	2.631 N/mm ²	3.117 N/mm ²	3.282 N/mm ²	3.400 N/mm ²	2.799 N/mm ²	3.030 N/mm ²
Shear adhesion *	14,40 N/mm ²	20 N/mm ²	16,20 N/mm ²	22,40 N/mm ²	4,50 N/mm ²	19 N/mm ²	N/A	33 N/mm ²	31,90 N/mm ²	31,1 N/mm ²	15,90 N/mm ²	30,80 N/mm ²	28,90 N/mm ²
Adhesion to steel **	>3,0 N/mm ²	2,0 N/mm ²	6,0 N/mm ²	3,4 N/mm ²	>4,5 N/mm ²		N/A	>7,5 N/mm ²	>7,5 N/mm ²	>7,5 N/mm ²	>6,5 N/mm ²	6,7 N/mm ²	4,5 N/mm ²
Specific volume	775 cm ³ / kg	709 cm ³ / kg	730 cm ³ / kg	680 cm ³ / kg	500 cm ³ / kg		735 cm ³ / kg	526 cm ³ / kg	535 cm ³ / kg	524 cm ³ / kg	556 cm ³ / kg	538 cm ³ / kg	658 cm ³ / kg
Heat resistance													
Corrosion	60°C (140°F)	60°C (140°F)	60°C (140°F)	160°C (320°F)	60°C (140°F)	120°C (248°F) peak 190°C (374°)		60°C (140°F)	60°C (140°F)	60°C (140°F)	60°C (140°F)	200°C (392°F)	220°C (428°F)
Light or no load	120°C (248°F)	120°C (248°F)	120°C (248°F)	220°C (430°F)	120°C (248°F)			100°C (212°F)	100°C (212°F)	100°C (212°F)	95°C (199°F)	250°C (482°F)	260°C (500°F)
For filling only	250°C (482°F)	250°C (482°F)	250°C (482°F)	300°C (570°F)	250°C (482°F)			160°C (320°F)	160°C (320°F)	160°C (320°F)	95°C (199°F)	300°C (572°F)	320°C (608°F)
Dielectric strength	10 KV/mm	10 KV/mm	10 KV/mm	10 KV/mm	N/A	N/A		10 KV/mm	10 KV/mm		N/A	N/A	10 KV/mm

Hardness	Shore D, DIN 53505
Tensile strength	N/mm ² (10kg/cm ²) DIN 53454
Compressive strength	N/mm ² DIN 53454
Shear adhesion *	Single-lap-joint acc. to ASTM D1002
Adhesion to steel **	N/mm ² (10kg/cm ²) / ISO 4624
Specific volume	cm ³ per kilogram

Every endeavour has been made to ensure that the information given herein is true and reliable, but it is given only for the guidance of our customers. The company cannot accept any responsibility for loss or damage, that may result from the use of the information, due to the possibility of variations of processing or working conditions and of workmanship outside our control. Users are advised to confirm the suitability of this product with their own test. All dimensions shown are approximate.

WENCON PROTECTIVE AND LIFE EXTENDING SOLUTIONS

BEFORE

DURING

AFTER

SEA WATER FILTER

Attacked by corrosion. Grit blasted and rebuild with Wencon Cream and protected with Wencon Coating white and blue.



SPLIT CASING PUMP

Bronze pump affected by corrosion / erosion. Support ring seats rebuild with Wencon Rapid. Protected with Wencon Coating white and blue.



THRUSTER GEAR CASING

Attacked by bi-metallic corrosion. Grit blasted and rebuild using Wencon Cream and protected with Wencon Coating white and blue.



RUDDER TRUNK BUSHING

Surface prepared and new bushing installed using Wencon Rapid in existing oversized seat. Bushing cast to fit, using Wencon Coating injected to fill the clearance.

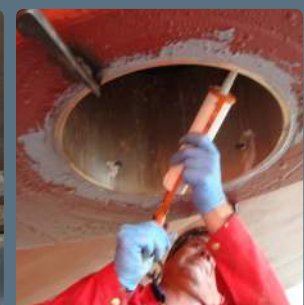

Dealer / Agent

 WENCON®

WENCON ApS · Jyllandsvej 15 · DK-5400 Bogense · Tel. +45 6481 1010 · wencon@wencon.com · www.wencon.com