

## Valve seat - corrosion

APPLICATION DATA SHEET No. 107

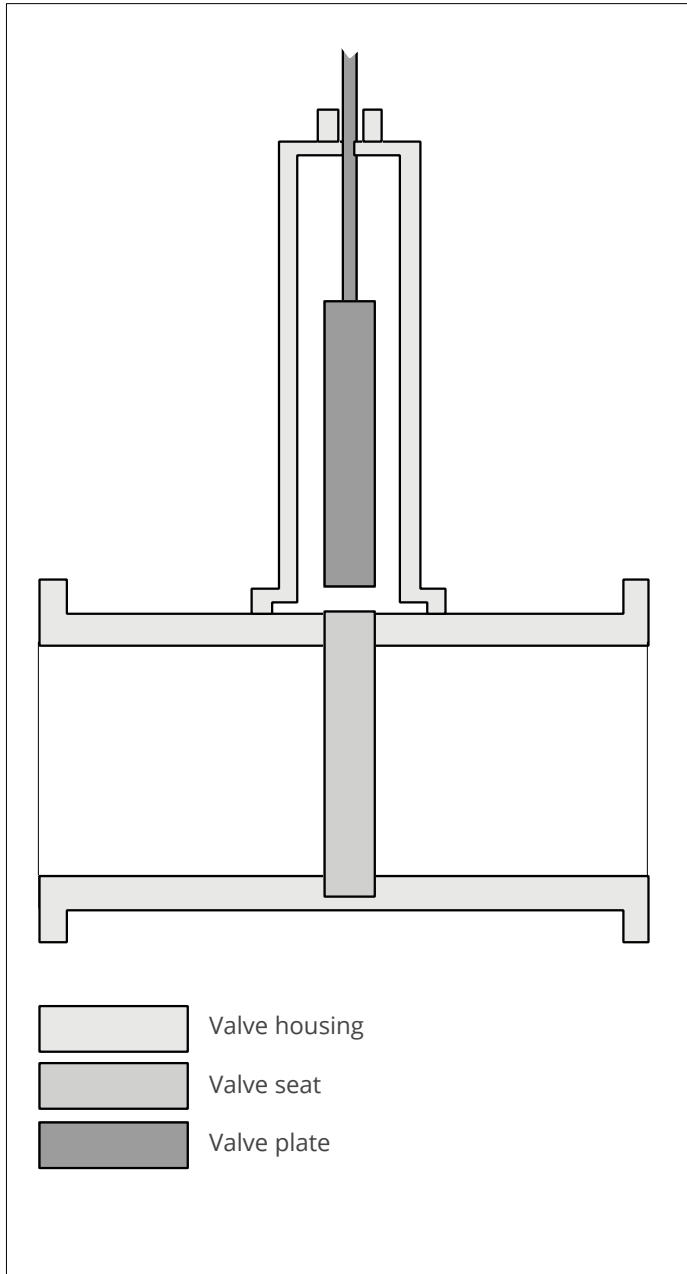

Leaks in valves often occur, due to corrosion in the seating. As a rule the valve is constructed using a number of different metals. Therefore there is every possibility of light acidic agents, such as sea water, causing bimetallic corrosion.

This application, deals only with emergency repair of a corroded seat. The complete renovation of valves are dealt with in another application sheet. Whether the valves in question are plate valves or butterfly and non-return valves, the method of application is much the same.

Clean the corroded seat acc. to Wencon surface preparation, next page.

Apply a coat of Wencon Release Agent to the valve plate. This will prevent adhesion. Mix and apply an adequate amount of Wencon Cream or Rapid to the valve seat and close the valve immediately afterwards.

When curing is completed open the valve and grind the seating edges to shape. Wencon adheres to all metals. Wencon retains its form and size during curing.

Please refer also to the application instructions accompanying the Wencon product.

## Wencon surface preparation

Choose the relevant surface preparation, depending on the nature of the job.

Surface preparation using dry blasting methods:

Application with Wencon products on a dry surface, at minimum 3°C above dew point.

1. Blast the machine part to SA 2,5 using sharp-edged blasting media, to a roughness of min. 75 microns.
2. Leave the part for sweating out salts in a warm place for at least 12 hours or heat it up to 30 - 40°C (86-104 °F) using gas torches.
3. Blast again to SA 2,5, prior to the application.
4. For parts containing a lot of water and salt, it may be necessary to repeat point 2 and 3, until the surface remains light grey, for at least 2 hours after blasting.
5. For optimal adhesion of Wencon products, always use Wencon Bio Cleaner or Wencon Cleaner prior to application. Follow one of below two methods:
  - 5.1 **Wencon Bio Cleaner**  
**Wet surface:** Apply Wencon Bio Cleaner and let it work for 5-10 min. If necessary use a brush, to make sure the surface is clean. Rinse off with clean water and wipe off with an absorbing cloth.  
  
**Dry surface:** Apply Wencon Bio Cleaner and let it work for 5-10 min. If necessary use a brush, to make sure the surface is clean. Rinse off with clean water and dry with an absorbing cloth or with compressed air for a completely dry surface. Hereafter any Wencon products can be applied.
  - 5.2 **Wencon Cleaner**  
After surface preparation, apply Wencon Cleaner with a brush and allow the product to evaporate before applying other Wencon products. Wencon Cleaner is non-flammable. Use only in large or well ventilated rooms.

Surface preparation using wet/damp methods:

Water jet the entire surface with water and sand to a standard equal, to SA 2,5 as described above.

If the surface is left wet after surface preparation, is it important to dry out the surface or alternatively use a Wencon UW product.

Surface preparation for emergency/temporary applications:

If above surface preparation methods are not possible, it may be necessary to use one of below methods:

- Blasting
- Grinding
- Needle Gunning

In emergency / temporary applications it may be difficult to prepare the surface according to above methods. In any case, it is important to clean the surface to SA 2,5 and 75 microns roughness. If possible dry the surface before applying. If not possible, use Wencon UW products.

For further information on Wencon surface preparation, please contact our Area Sales Managers.