

Pipe repair - heating coils upper tank area

APPLICATION DATA SHEET No. 149

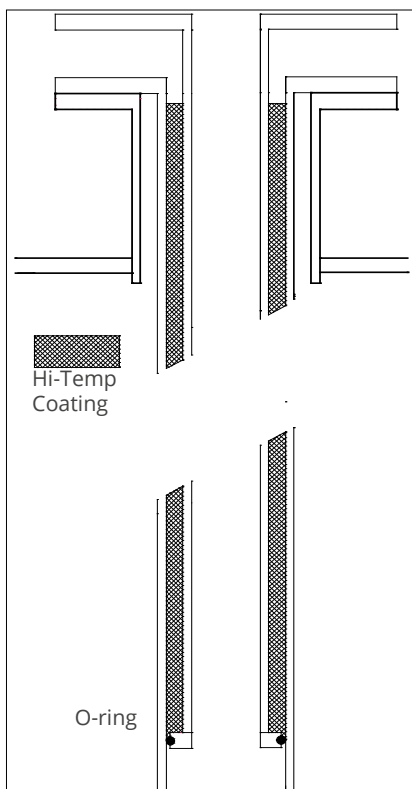
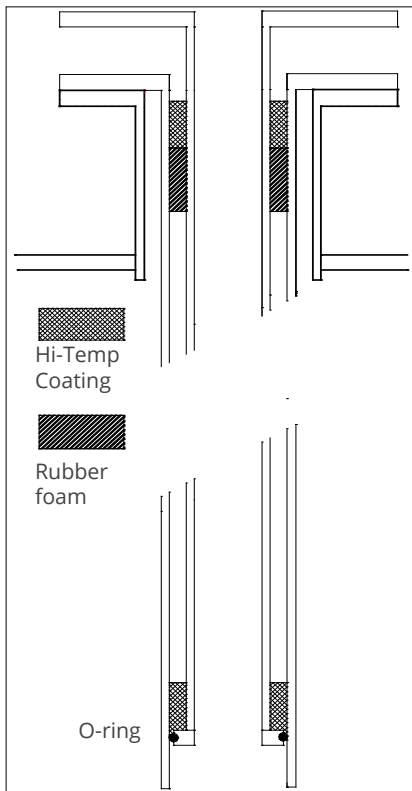

This area is normally very difficult to reach, as it demands the use of scaffolding from inside the tank. Below find an alternative method of repairing this kind of damage from the deck-side.

Cast an insert pipe into the original pipe by injecting Wencon Hi Temp, which also helps to delay the bi-metallic corrosion. The insert pipe will naturally reduce the flow in the heating medium, so it has to be considered how much this will effect the heating capacity. An insert pipe is prepared, 2-3 cm (0,8-1,2 inch) smaller in outer diameter than the inner diameter of the original pipe, and in a length about 20 cm (8 inch) below the damaged area. In the bottom of the insert pipe there has to be a groove for an O-ring, to seal for the later injected Wencon Hi Temp Coating. The insert pipe can be made with a flange on the top. Make sure that the insert pipe will not fall down in the original pipe during the curing process. In case of larger holes in the original pipes, use method 1, if there are no leaks we recommend method 2.

Method 1

1. Slide in the insert pipe. If you choose a flange in the top on the insert pipe, leave approximately 10-15 cm (4-6 inch) free for injecting.
2. Mix Wencon Hi-Temp Coating and fill it in a standard cartridge for a "sealant-gun".
3. By means of a thin-walled steel- or plastic pipe mounted on the gun, a layer of 5 cm Coating is injected in the bottom area between the two pipes.
4. Remove the filling-pipe, and push in a layer of approximately 5 cm (2 inch) of rubber-foam to form a seal between the two pipes, and force it down 5-10 cm (2-4 inch) under the flange surface.
5. Fill the remaining gap between the two pipes with Wencon Hi-Temp. If the insert pipe has a flange, use Wencon Hi Temp coating as a sealing compound between the old and the new flange.
6. Let the coating cure for 8-10 hours. (The rubber-foam is used, to prevent coating leaking into the tank-area through holes in the damaged surface)

Method 2

1. Slide in the insert pipe into the original pipe.
2. Mix Wencon Hi-Temp Coating and fill it in a standard cartridge for a "sealant-gun".
3. By means of a thin-walled steel- or plastic pipe mounted on the gun, fill up the gap between the two pipes.
4. Let the coating cure for 8-10 hours.

Wencon surface preparation

Choose the relevant surface preparation, depending on the nature of the job.

Surface preparation using dry blasting methods:

Application with Wencon products on a dry surface, at minimum 3°C above dew point.

1. Blast the machine part to SA 2,5 using sharp-edged blasting media, to a roughness of min. 75 microns.
2. Leave the part for sweating out salts in a warm place for at least 12 hours or heat it up to 30 - 40°C (86-104 °F) using gas torches.
3. Blast again to SA 2,5, prior to the application.
4. For parts containing a lot of water and salt, it may be necessary to repeat point 2 and 3, until the surface remains light grey, for at least 2 hours after blasting.
5. For optimal adhesion of Wencon products, always use Wencon Bio Cleaner or Wencon Cleaner prior to application. Follow one of below two methods:
 - 5.1 **Wencon Bio Cleaner**

Wet surface: Apply Wencon Bio Cleaner and let it work for 5-10 min. If necessary use a brush, to make sure the surface is clean. Rinse off with clean water and wipe off with an absorbing cloth.

Dry surface: Apply Wencon Bio Cleaner and let it work for 5-10 min. If necessary use a brush, to make sure the surface is clean. Rinse off with clean water and dry with an absorbing cloth or with compressed air for a completely dry surface. Hereafter any Wencon products can be applied.
 - 5.2 **Wencon Cleaner**

After surface preparation, apply Wencon Cleaner with a brush and allow the product to evaporate before applying other Wencon products. Wencon Cleaner is non-flammable. Use only in large or well ventilated rooms.

Surface preparation using wet/damp methods:

Water jet the entire surface with water and sand to a standard equal, to SA 2,5 as described above.

If the surface is left wet after surface preparation, is it important to dry out the surface or alternatively use a Wencon UW product.

Surface preparation for emergency/temporary applications:

If above surface preparation methods are not possible, it may be necessary to use one of below methods:

- Blasting
- Grinding
- Needle Gunning

In emergency / temporary applications it may be difficult to prepare the surface according to above methods. In any case, it is important to clean the surface to SA 2,5 and 75 microns roughness. If possible dry the surface before applying. If not possible, use Wencon UW products.

For further information on Wencon surface preparation, please contact our Area Sales Managers.