

Engine, top land surface for wet liner - Corrosion

APPLICATION DATA SHEET No. 138

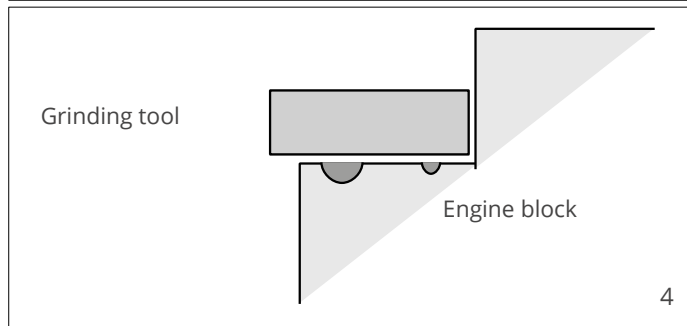
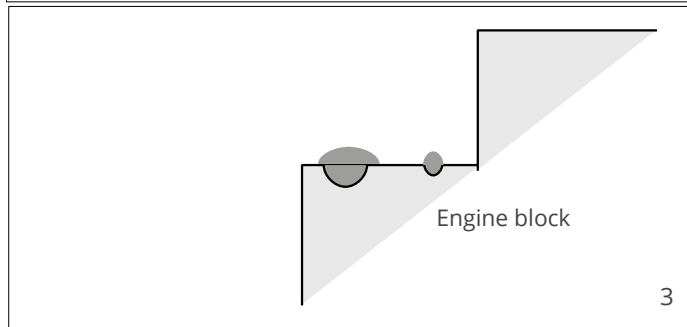
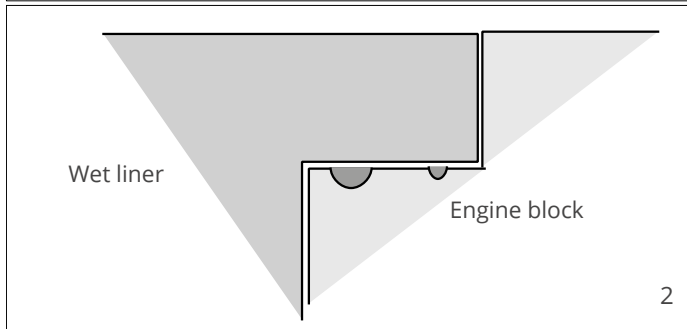
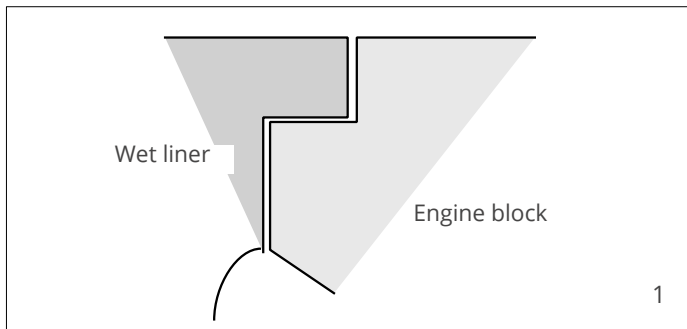

Problem:

Corrosion in top land surface for wet liners.

Purpose of application:

To prevent further corrosion in the pits and to prevent leakage.

1. Grind the pitting in the surface to bare metal using small rotating equipment.
2. Prepare the surface thoroughly acc. to Wencon surface preparation, next page.
3. Mix and apply a suitable amount of Wencon Ceramic Cream or Ceramic Coating to the affected areas, and leave the surface slightly proud, see ill. 3.
4. After semi-curing, cut most of the excess material away with a knife, and grind the surface with appropriate grinding tool as in ill. 4.

Neither sea water, nor oil will have damaging effect on the cured repair material.

Alternative products: Wencon Hi-Temp

Wencon surface preparation

Choose the relevant surface preparation, depending on the nature of the job.

Surface preparation using dry blasting methods:

Application with Wencon products on a dry surface, at minimum 3°C above dew point.

1. Blast the machine part to SA 2,5 using sharp-edged blasting media, to a roughness of min. 75 microns.
2. Leave the part for sweating out salts in a warm place for at least 12 hours or heat it up to 30 - 40°C (86-104 °F) using gas torches.
3. Blast again to SA 2,5, prior to the application.
4. For parts containing a lot of water and salt, it may be necessary to repeat point 2 and 3, until the surface remains light grey, for at least 2 hours after blasting.
5. For optimal adhesion of Wencon products, always use Wencon Bio Cleaner or Wencon Cleaner prior to application. Follow one of below two methods:
 - 5.1 **Wencon Bio Cleaner**

Wet surface: Apply Wencon Bio Cleaner and let it work for 5-10 min. If necessary use a brush, to make sure the surface is clean. Rinse off with clean water and wipe off with an absorbing cloth.

Dry surface: Apply Wencon Bio Cleaner and let it work for 5-10 min. If necessary use a brush, to make sure the surface is clean. Rinse off with clean water and dry with an absorbing cloth or with compressed air for a completely dry surface. Hereafter any Wencon products can be applied.
 - 5.2 **Wencon Cleaner**

After surface preparation, apply Wencon Cleaner with a brush and allow the product to evaporate before applying other Wencon products. Wencon Cleaner is non-flammable. Use only in large or well ventilated rooms.

Surface preparation using wet/damp methods:

Water jet the entire surface with water and sand to a standard equal, to SA 2,5 as described above.

If the surface is left wet after surface preparation, is it important to dry out the surface or alternatively use a Wencon UW product.

Surface preparation for emergency/temporary applications:

If above surface preparation methods are not possible, it may be necessary to use one of below methods:

- Blasting
- Grinding
- Needle Gunning

In emergency / temporary applications it may be difficult to prepare the surface according to above methods. In any case, it is important to clean the surface to SA 2,5 and 75 microns roughness. If possible dry the surface before applying. If not possible, use Wencon UW products.

For further information on Wencon surface preparation, please contact our Area Sales Managers.